

HyDraw[®] CAD 2019

'Power-to-Design' Circuits

Help



HyDraw[®] CAD 2019

'Power-to-Design' circuits



VEST, Inc. 3250 W, Big Beaver Road, Suite 440, Troy, MI 48084 USA

+1 248 649 9550

sales@VESTusa.com

<https://VESTusa.com>

VEST, Inc.

HyDraw® CAD 2019 Software License & Services Agreement

Carefully read the terms and conditions of this Agreement before proceeding further. Using this software indicates your acceptance of these terms and conditions.

License

VEST, Incorporated (“we, our, us”) grants the Licensee (“you, your”) a non-transferable and non-exclusive license to use the software product in the specified quantity only, subject to and conditioned on Licensee’s continuous compliance with this Agreement and payment of the applicable fees.

You may not:

1. Distribute, sublicense or copy any portion of the licensed software product
2. Modify or prepare derivative works from the licensed software product
3. Use the licensed software product in multiple computers or multiple user arrangements unless that use is covered by an individual license for each computer or user.

You agree that the licensed software product belongs to us and you agree to keep confidential and use your best efforts to prevent and protect the contents of the licensed software product from unauthorized disclosure.

Limited Warranty

VEST, Inc. warrants that, as of the date on which the Software Products are delivered and licensed to Licensee and for ninety (90) days thereafter, the (“Warranty Period”), the Software Products will provide the general features and functions described in the User Documentation of the Software Product. VEST’s entire liability and Licensee’s exclusive remedy during the Warranty Period (“Limited Warranty”) will be, (i) to attempt to correct or work around errors, if any, or (ii) to refund the Software fees, if any, paid by Licensee. Such refund is subject to the return, of the Software License by the Licensee, if the license has already been issued. This warranty does not cover damage caused by virus, improper use or neglect.

The Software product is furnished “AS IS” and without warranty as to the performance or results you may obtain by using the licensed software product or that it will be error free. You assume the entire risk as to the results and performance of the licensed software product. To get warranty service during the 90-day Warranty Period, you may return the product license to VEST, Inc., with a description of the problem.

Limitations of Liability

YOU UNDERSTAND AND AGREE AS FOLLOWS:

- A. Warranties in this Agreement replace all other warranties, express or implied, including any warranties of merchantability or fitness for a particular purpose. We disclaim and exclude all other warranties.
- B. We will not be liable for any loss or damage caused by delay in furnishing a licensed software product or any other performance under this Agreement.
- C. Our entire liability and your exclusive remedies for our liability of any kind (including liability for negligence) for the licensed software product covered by the agreement and all other performance or non-performance by us under or related to this Agreement are limited to the remedies specified by this Agreement.
- D. In no event will our liability of any kind include any special incidental or consequential damages, for loss of profits, use, revenue or data; or for business interruption (regardless of the legal theory for seeking such damages or other liability. In addition, the liability of VEST, Inc., and its partners, arising out of or relating to any VEST, Inc. software or service will not exceed the amount paid or payable by Licensee for such software or services.
- E. Subscribers to manufacturer and other data services related to our Software hereby acknowledge and agree that the services are provided by VEST, Inc. on an “As Is” basis, and the Subscriber’s access and use of the service is at its sole risk. VEST, Inc. and the manufacturers expressly disclaim all warranties of any kind, whether express or implied, including any damages that may result from the use of this service

VEST Inc. makes no warranty that the services will meet the requirements of the Subscriber, or that the services will be uninterrupted, or error-free, nor does VEST Inc. make any warranty as to the results that may be obtained through the use of the services. Subscriber understands and agrees that any data downloaded through the use of the service is done at the sole risk of the Subscriber and the Subscriber will be solely responsible for any damage which might result from use of this data.

F. Special notice to consumers: some states do not allow the exclusion of implied warranties, so the above exclusion may not apply to you. The warranty gives you special legal rights, and you may also have other rights, which vary from state to state.

Termination

This Agreement is effective until terminated. You may terminate it any time by returning the licensed software product. It will also terminate if you do not comply with any term or condition of this agreement. VEST, Inc. may, as an alternative to termination, suspend Licensee’s license if the Licensee fails to make payment to VEST, Inc. or its Distributor, or otherwise fails to comply with the provisions of this Agreement.

General

You are responsible for installation, management and operation of the licensed software product.

© 2002-2018, VEST, Inc. All rights reserved.

Contents

1. Introduction	2	31. Update Property List.....	106	Collate Files.....	151
2. Support.....	4	32. Purge Properties.....	107	64. Collate Documents	152
Workspace.....	5	33. Purge Price Data	109	65. Collate CAD Files.....	153
3. HyDraw Startup	6	34. Edit Solenoid Information.....	110	Calculator	154
4. HyDraw CAD Ribbon Menu.....	7	35. Update from Excel.....	111	66. Unit Converter	155
5. HyDraw Shortcuts.....	8	Modify Symbols.....	113	MDTools Interface	156
6. HyDraw Library Explorer.....	9	36. Move Symbol.....	114	67. Export to MDTools.....	157
7. HyDraw Property Manager	12	37. Align Symbols	115	Convert.....	161
8. HyDraw Options	17	38. Rotate Symbols.....	116	68. Convert to HyDraw	162
Insert Symbols	47	39. Flip Symbols.....	117	69. Update Drawing	164
9. Insert Symbol.....	48	40. Align Symbol Ports.....	118	Check.....	165
10. Insert External Port.....	62	41. Align External Port Names	119	70. Schematic Check.....	166
11. Insert Sub-Systems	66	42. Edit Symbol Port.....	120	Title Block	168
12. Insert from Parts List	74	43. Edit in Place	121	71. Insert Title Block.....	169
13. Insert Terminators	75	44. Delete a Symbol.....	123	72. Edit Title Block.....	170
14. Insert Symbol Port	76	45. Stack Symbols.....	124	FluidPowerTools.com	171
15. Insert Envelope.....	77	46. Show/Hide Port Names	125	73. Data Access Settings.....	172
16. Insert Gauge Port	78	47. Show/Hide Design Notes	126	74. Help for FluidPowerTools.com	173
17. Insert Orifice Disc	79	48. Edit Design Notes	127	75. Internet Settings.....	177
18. Insert Jumping Reference	80	49. Edit Jumping Reference	128	HyDraw CAD Help	178
Make Connections	81	50. Find Jumping Reference	129	76. Help	179
19. Insert Connection	82	Annotations	130	77. License Information.....	180
20. Connect Ports and Symbols	83	51. Change Text Height	131	78. About HyDraw	181
21. Fetch Pipe, Tube and Hose Data.....	84	52. Rotate Property Text	132	Installation & Setup	182
Modify Connection	85	53. Show/Hide Properties	133	79. HyDraw CAD 2019 Installation.....	183
22. Stretch Connections	86	54. Reassign Item ID	134	80. Library Network Configuration	191
23. Match Connections	87	55. Reassign Hose ID	135	81. Set Online Services (FPT)	192
24. Merge Connection.....	88	56. Update Balloons	136	82. Build New Symbols	194
25. Reset Connections	89	57. Add New Display Format	137	83. Build New External Ports	200
Specify Properties	90	Lists.....	138	84. Build New Sub-Systems	203
26. Selected Item Properties	91	58. Create and Insert Parts List.....	139	85. Manage HyDraw CAD Drawings thro' Vault	209
27. System Properties	102	59. Create and Insert Ports List	143		
28. Edit Properties.....	103	60. Create and Insert Hose List.....	145		
29. Copy Properties	104	61. Create Solenoid Actuation Chart	147		
30. Refresh Properties.....	105	62. Create and Insert Net List	148		
		63. Create Design Note List	150		

1. Introduction

Welcome to VEST HyDraw® CAD 2019

Create accurate, error free, professionally drawn hydraulic circuits, part lists, and quotations quickly and easily.

Drag-and-drop 'smart' symbols into a drawing with point-and-click component selection.

The 'smart' connection lines snap to ports and self-route with jumpers.

Auto BOM generation ensures accuracy of your Bill of Materials. Easily insert it into the circuit drawing or export it to Microsoft Excel.

Get started with over 8,000 ISO 1219-1 compliant symbols covering both industrial and mobile hydraulics. 'Remember' your data and rules using HyDraw custom database. Ensure up-to-date pricing of components by linking your ERP data to HyDraw.

Circuit design data can be ported to downstream manifold design and CAM systems.

HyDraw can access manufacturer component data from FluidPowerTools.com, a fee-based service from VEST.

Use **HyDraw** and ensure your competitive edge.

The screenshot displays the HyDraw CAD 2019 software interface. The main window shows a hydraulic circuit drawing with various components like pumps, valves, and cylinders connected by lines. The interface includes a menu bar at the top, a toolbar, and a ribbon. On the left, the 'HYDRAW LIBRARY EXPLORER' is visible, showing a search bar and a list of hydraulic symbols categorized by type (e.g., Pump, Valve, Cylinder). On the right, the 'HYDRAW PROPERTY MANAGER' is open, displaying a table of components and their properties. The table includes columns for Item ID, Qty, Part Name, Description, and Manufacturer. Below the table, there are sections for 'Design requirements', 'Model data', and 'Accessories'. The drawing area is labeled with 'A', 'B', 'X', and 'Y' axes.

ITEM ID	QTY	PART NAME	DESCRIPTION	MANUFACTURER
1	1	014-01550544	PRESSURE GAUGE 1-5000 PSI	DOMINIC
2	1	3P1300	PUMP MOTOR ASSEMBLY	DUSTON
3	1	12510	HOSE	TUMEN-INDIA
4	1	106-10	SECTION STRAINER	BATON
5	2	1A48P2-N	SMALL 2" X 1/2" PRESSURE METER VALVE	PRANER
6	1	300400	SHOCK VALVE	BATON
7	1	1A61A1VIEW200A	DIRECTION CONTROL VALVE	HYDASC
8	1	304C-REV02P220	RELIEF VALVE	BATON
9	1	2210-1000	NEEDLE VALVE	HYDASC
10	1	13010	PLUG 1/2" TEMPERATURE DETECTOR	TUMEN-INDIA
11	1	3P116	PULLER/BREATHER	TUMEN-INDIA
12	1	10000102	BLACK PULVERIZED COPPER	BOCC-RESEARCH

ITEM NAME	NET CUP	NET PRESSURE (PSI)
NET-1	1/2" NPT	2000
NET-2	1/2" NPT, 3/4"	2000
NET-3	3/4" PS, 1/2" PS, 3/4"	2000
NET-4	1/2" NPT, 3/4"	2000
NET-5	1/2" NPT, 3/4"	2000

FUNCTION	QTY	UNIT	DESCRIPTION
CYLINDER EXT	1	Ø	HOSE
CYLINDER RET	1	Ø	HOSE

HyDraw CAD drawing area with HyDraw CAD Ribbon menu, HyDraw Library Explorer, and HyDraw Property Manager

HyDraw® CAD 2019 is easy to use. It works seamlessly with its own ribbon menu. HyDraw symbols are located quickly by navigating logically structured menus. Sets of related symbols are shown together and any required symbol can be inserted into the drawing by drag-and-drop method or double-click on a symbol. You can insert generic symbols or model code specific component symbols into the library. Edit parametric properties of the inserted symbols, when needed.

HyDraw Library

The HyDraw library accommodates a wide range of simple and complex graphical component symbols, and schematic diagrams covering both Industrial and Mobile Hydraulics. Designed in accordance with ISO1219-1:2012, Fluid Power Systems and Components - Graphic Symbols and Circuit Diagrams - Part 1: Graphic Symbols for Conventional Use and Data Processing Applications. A few percentile deviations from ISO standard necessitated keeping in view the large variants of symbols and customer base. The HyDraw library includes both Slip-in and Screw-in Cartridge valves and associated symbols for manifold design circuits.

Smart Symbols

HyDraw symbols are created using primitive shapes, such as lines, polylines, rectangles, squares, circles, circular arcs, ellipsis. They represent components with specified functions or method of operation in the de-energized (at rest) position, or component specific rule that do not have a clearly defined de-energized position. A pool of ISO specified primitive shapes are included in the library to help you design your own generic symbols. HyDraw symbols also include port identification and port numbering, which is essential for manifold design.

ISO guidelines

VEST has adhered to ISO guidelines of Module System (1Module = 2 Millimeter), where the symbol fits into a grid and presents a symmetry. The use of layer properties for assigning ISO defined color to Supply line, Return line, Pilot line, Drain line, Envelope line, and Flow direction exhibits appealing color graphics, which help in instant understanding of the operational aspect of the component. Layer properties are also utilized for naming ports, positions and solenoids. (both US and European pattern)

Search

Save time and effort with the new and powerful HyDraw CAD 2019 Search from library command. Search general or OEM specific symbols and circuits from www.FluidPowerTools.com.

Teamwork

HyDraw helps standardization and teamwork. Multiple users within a local area network can share a common HyDraw library. This enhances productivity of the design and engineering team.

Customization

Customize HyDraw to your specific need using the library and data management console. Save custom components data with symbols tagged to a specific model code and relevant OEM catalog data.

More...

OEM-specific circuit design with Parts List from component properties held in the library make the software very productive.

Net List creation, Manifold Cost estimation and interface to FluidPowerTools.com enable significant cost and time-savings.

Work Smart! Use HyDraw® today.

2. Support

Help

The HyDraw® CAD 2019 Help provides comprehensive information on the features, commands, usage, processes, and design methodology of HyDraw.

The Help can be used as a comprehensive reference to the command set and usage of HyDraw.

****Click the HyDraw command on the Help ribbon menu to view the user manual in the Adobe Acrobat .pdf format.**

Support

If you have a question about HyDraw CAD 2019 email us at support@VESTusa.com.

Please include the following:

- Version number of the software you use.
To see the version of HyDraw on your machine, Click **About HyDraw** from the Help ribbon menu.
- Configuration of your machine.
- Exact messages, if any, on the screen.
Send a screen capture, if possible.
- Description of the problem and what you were doing when the problem occurred.
- Description of how you tried to solve the problem.

*****Click the About HyDraw command on the Help ribbon menu to view the About HyDraw message box indicating the software version number.**

The Contents and Index listing guides you to relevant material for study and reference.

The User Manual Adobe Acrobat file includes a left-hand column nested menu for easy chapter navigation. (Acrobat Reader: View > Navigation Panels > Bookmarks)

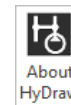

About HyDraw CAD

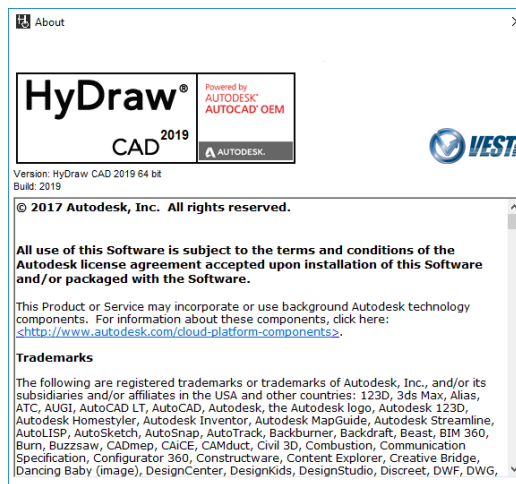

About HyDraw message box

Workspace

HyDraw CAD 2019 Sample Circuit.dwg

3 HyDraw Startup

4 HyDraw CAD Ribbon Menu

5 HyDraw Shortcuts

6 HyDraw Library Explorer

7 HyDraw Property Manager

8 HyDraw Options

HYDRAW PROPERTY MANAGER

Selected Item System

Symbol Exclude from Parts List

Item ID 7

Assembly ID Balloun Style

Circle

Display Setting

Design requirements

Flow (gpm) 6

Pressure (psi) 3000

Model data

Model Code 4WES/6X/EW230N9K4

Model Family 4WES

Part Number 6112MB

Description Direction Control Valve

Manufacturer Hydac

Cost 27

Assembly Cost 5

List Price 236

Rated Flow (gpm) 21

Pressure Loss @ Rated Flow 145

Rated Pressure (psi) 5000

Cavity/Footprint/Interface D03

Malfunction Flow (gpm) 21

Voltage 230

Frequency 50

Bolt Shoulder Height (in) 1.4

Installation Torque (Steel) 5.9 lb ft / 8 Nm

Installation Torque (Aluminum) 5.9 lb ft / 8 Nm

Catalog Number RE 23178/08 08

ITEM ID	PORT TYPE	DESCRIPTION	PORT SIZE
BR. C, LVL. R	SAE O-RING	#6 SAE	#6 SAE
MC, MP, PPR	SAE O-RING	#4 SAE	#4 SAE
PI, P2, PRL T	SAE O-RING	#10 SAE	#10 SAE
TR1	SAE O-RING	#9 SAE	#9 SAE

NET NAME	NET LIST	NET PRESSURE (PSI)
NET-1	MC, 9-2, C	3000
NET-2	7-T, T, 5A-2	2500
NET-3	7-P, P2, P1, MP, 5A-1	3500
NET-4	MR, 6-2, R, SB-1	2000
NET-6	7-1, 7-B	2500
NET-7	4-1, SB-2, 7-A	4000

FUNCTION	7-SV1	7-SV2
CYLINDER EXT.	<input type="radio"/>	<input type="radio"/>
CYLINDER RET.	<input type="radio"/>	<input type="radio"/>

HOSE ID	QUANTITY	DESCRIPTION
3	1	HOSE

NAME	DATE	COMPANY
BROWN, C.A.	06/04/2018	VEST, INC.
CHECKER, J.W.	06/04/2018	
APPROVER		

INSERT 1ST OR GRID ANGLE PROJECTION SYMBOL HERE

THE INFORMATION CONTAINED IN THIS DRAWING IS THE PROPERTY OF VEST, INC. IT IS TO BE USED FOR THE EXCLUSIVE PURPOSE OF THE PROJECT AND IS NOT TO BE REPRODUCED OR TRANSMITTED IN ANY FORM OR BY ANY MEANS, ELECTRONIC OR MECHANICAL, INCLUDING PHOTOCOPYING, RECORDING, OR BY ANY INFORMATION STORAGE AND RETRIEVAL SYSTEM, WITHOUT THE WRITTEN PERMISSION OF VEST, INC.

CYLINDER CONTROL

MATERIAL: HYDRAULIC STEEL

FINISH: HYDRAULIC STEEL

DO NOT SCALE DRAWING

SIZE: B

SCALE: 1" = 1" / 1"

REV: 1

DATE: 06/04/2018

DRAWN BY: C.A. BROWN

CHECKED BY: J.W. CHECKER

APPROVED BY: [Signature]

DATE: 06/04/2018

COMPANY: VEST, INC.

PROJECT: HYDCA080108001

SHEET: 1 OF 1

Navigation: Type a command

Model Layout1

PAPER MODEL

Annotation scale of the current view
Click to adjust scale

3. HyDraw Startup

Note:

For HyDraw® CAD installation, refer Ch 79.

Open HyDraw CAD 2019

- Double click the HyDraw CAD 2019 desktop shortcut icon.

Alternatively,

Click **Start**

> All Apps

> HyDraw CAD 2019

> **HyDraw CAD 2019**

HyDraw CAD opens with the Ribbon menu, Library Explorer and Property Manager.

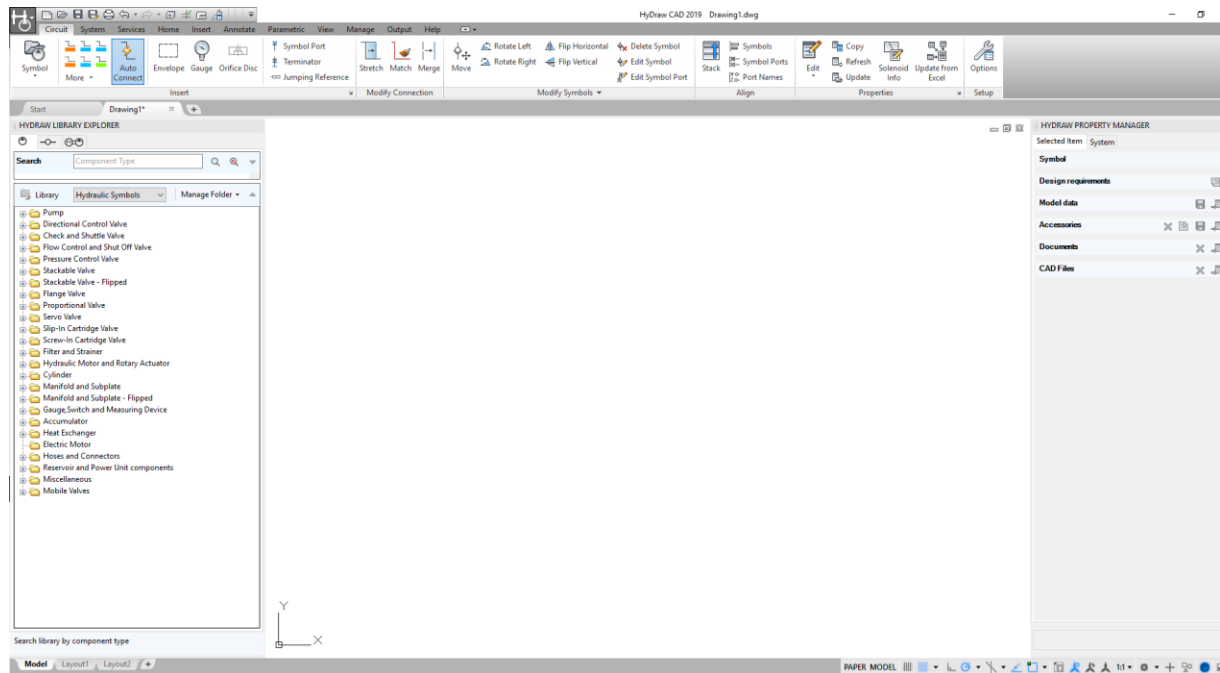

HyDraw CAD opens with Library Explorer and Property Manager

4. HyDraw CAD Ribbon Menu

HyDraw® CAD has a ribbon menu with four tabs, Circuit, System, Services, and Help for ready access to the frequently used commands.

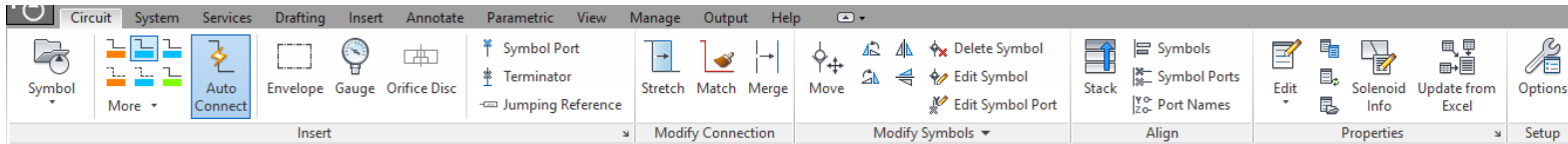

HyDraw CAD – Circuit Ribbon menu

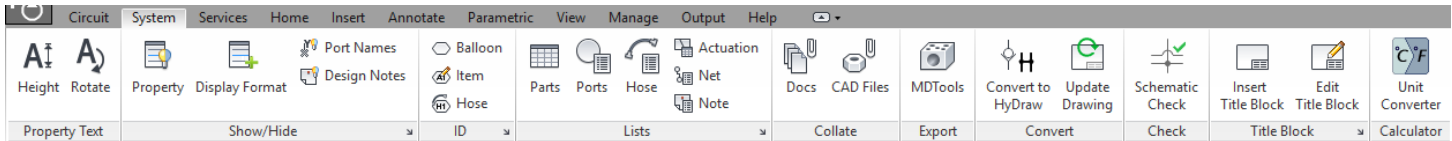

HyDraw CAD – System Ribbon menu

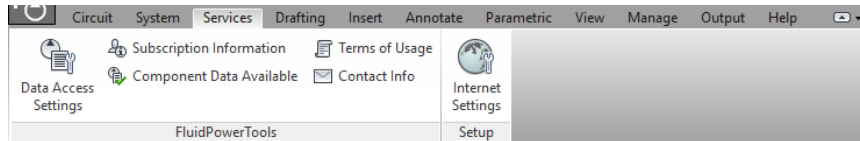

HyDraw CAD – Services Ribbon Menu

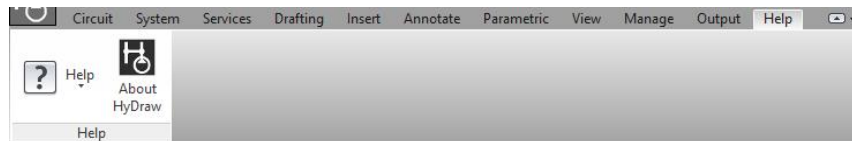

HyDraw CAD – Help Ribbon Menu

5. HyDraw Shortcuts

Shortcut command for HyDraw introduced for easy access from command line.

The predefined HyDraw shortcuts or aliases:

LICENSEINFO HyDraw CAD 2019 License Details
YL Library Explorer
YP Property Manager
YCP Pressure Connection Line
YCR Reservoir Connection Line
YCS Suction Connection Line
YCC Control Connection Line
YCD Drain Connection Line
YCW Working Connection Line
YC1 Custom Connection Line1
YC2 Custom Connection Line2
YC3 Custom Connection Line3
YC4 Custom Connection Line4
YC5 Custom Connection Line5
YE Insert Envelope
YG Insert Gauge Port
YM Match Connection Properties
YR Refresh Properties
YB Update Balloon
YI Assign Item ID
YPA Parts List
YPO Ports List
YN Net List
YO HyDraw Options

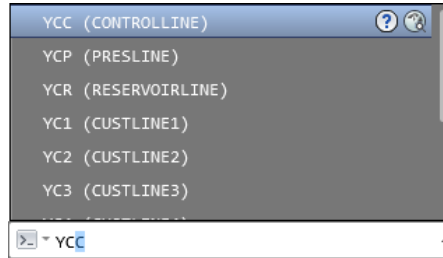

Command Line HyDraw shortcuts or aliases

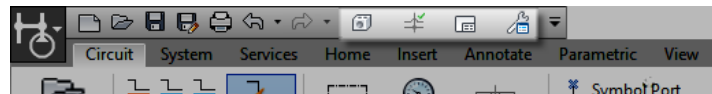

Quick Access Toolbar

You can also, add HyDraw Ribbon Menu commands to Quick Access toolbar.

6. HyDraw Library Explorer

The HyDraw® Library Explorer provides access to symbols, external ports, components and sub-systems. Locate them using either the tree view structure or the search option

The screenshot displays the HyDraw CAD 2019 interface. On the left, the 'HYDRAW LIBRARY EXPLORER' is open, showing a search bar and a library of hydraulic symbols such as 'Pump', 'Directional Control Valve', 'Check and Shuttle Valve', 'Flow Control and Shut Off Valve', 'Pressure Control Valve', 'Stackable Valve', 'Stackable Valve - Flipped', 'Flange Valve', 'Proportional Valve', 'Servo Valve', 'Slip-In Cartridge Valve', 'Screw-In Cartridge Valve', 'Filter and Strainer', 'Hydraulic Motor and Rotary Actuator', 'Cylinder', 'Manifold and Subplate', 'Manifold and Subplate - Flipped', 'Gauge, Switch and Measuring Device', 'Accumulator', 'Heat Exchanger', 'Electric Motor', 'Hoses and Connectors', 'Reservoir and Power Unit components', 'Miscellaneous', and 'Mobile Valves'. The main workspace shows a hydraulic schematic with various components like pumps, valves, cylinders, and filters, each labeled with a number and port type. On the right, there are two tables: a main parts list and a smaller table for hose specifications.

ITEM ID	QTY	MODEL CODE	DESCRIPTION	MANUFACTURER
1	3	DYN-C-FP-R04SAE	PRESSURE GAGE, 6-5000 PSI	DYNAMIC
2	1	RP2700	PUMP MOTOR ASSEMBLY	CUSTOM
3	1	P30-100	HOSE	HYKEN-INDIA
4	1	F30-100	SUCTION STRAINER	EATON
5	2	AR400CFE-N	DIRECT ACTING PRESSURE RELIEF VALVE	PARSER
6	1	CX3000N	CHECK VALVE	EATON
7	1	LM60A-V-CW230NKA	DIRECTION CONTROL VALVE	HYDAC
8	1	SAAS105DEBP003	FILTER	EATON
9	1	S200-A1-0NH	NEEDLE VALVE	HYDAC
10	1	LS107	FLD47 & TEMPERATURE SWITCH	HYKEN-INDIA
11	1	BR210	FILLER/BREATHER	HYKEN-INDIA
12	1	R90 W P022	BLACK MATING CONNECTOR	BOSSCH REXROTH

ITEM ID	PORT TYPE	DESCRIPTION	PORT SIZE
BR, C, LVL, R	SAE O-RING	#6 SAE	#6 SAE
MC, MP, MR	SAE O-RING	#4 SAE	#4 SAE
P1, P2, PR1, T	SAE O-RING	#8 SAE	#8 SAE
TR1	SAE O-RING	#10 SAE	#10 SAE

NET NAME	NET LIST	NET PRESSURE (PSI)
NET-1	MC, 3-2, C	3000
NET-2	T-7, T, SA-2	2500
NET-3	T-7-P, P2, P1, MP, SA-1	3500
NET-4	PR, 3-2, R, SB-1	2000
NET-5	3-1, 3-B	2500
NET-7	3-1, SB-2, T-3	4000

FUNCTION	T-5V1	T-5V2
CYLINDER EXT.	<input type="radio"/>	<input type="radio"/>
CYLINDER RET.	<input type="radio"/>	<input type="radio"/>

HOSE ID	QUANTITY	DESCRIPTION
3	1	HOSE

INSERT LIST	DATE	BY	APPROVED	TITLE
DR	SRD			WEST, INC.
DESIGNER	DR			
APPROVED				

MATERIAL	SIZE	QUANTITY	REV
HYDRAULIC OIL	B	HYDCAE00100100	1

Symbols and external ports inserted from HyDraw Library Explorer to design schematic

1. Open HyDraw Library Explorer

- Click Circuit > **From Library Explorer** from the Symbol option on the HyDraw® CAD 2019 ribbon menu.

Alternatively,

- Click Circuit > Symbol  on the HyDraw ribbon menu.

The HyDraw Library Explorer dockable window displays and docks on the left of the screen.

2. Move HyDraw Library Explorer

- Select **HyDraw Library Explorer** using the caption bar and drag or dock it to the desired location.

HyDraw stores the information about the docking location of the Library Explorer.

3. Show/Hide HyDraw Library Explorer

- Use the automatic **Show/Hide** feature of the Library Explorer to maximize the drawing space.
- Right click on the window border and uncheck **Allow Docking**.
- Use  icon to Show/Hide the Library Explorer.

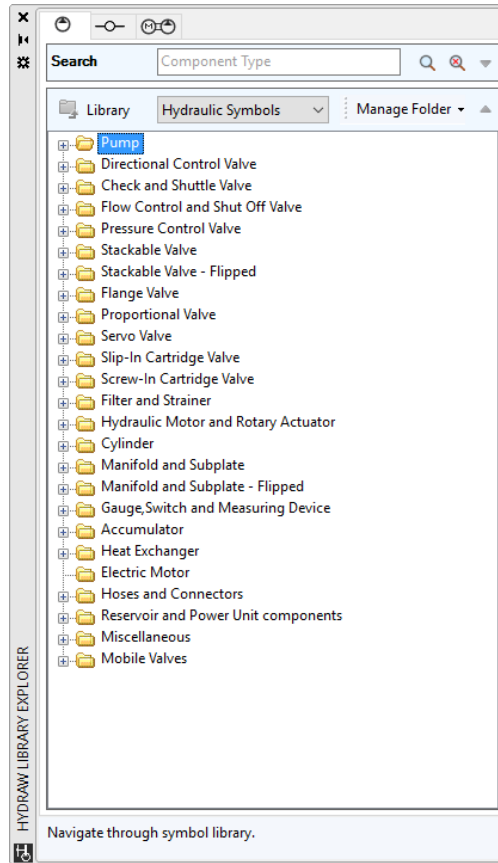

Show/Hide HyDraw Library Explorer

4. Load HyDraw Library Explorer on Startup

- Select Circuit >  from the HyDraw® CAD 2019 ribbon menu.
- Click the **Misc.** tab.
- Select **Library Explorer** from the Load on startup group box.

When subsequently opened, the Library Explorer docks to its previous location.

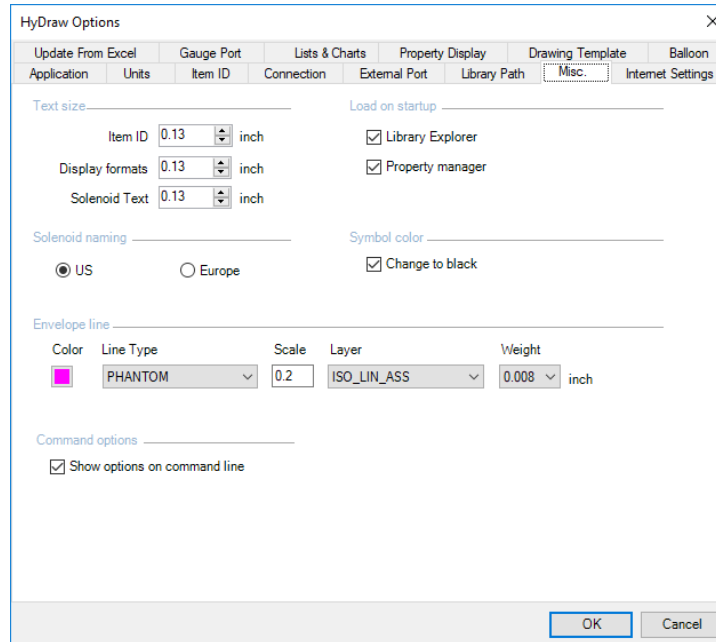

HyDraw Options: Misc.

7. HyDraw Property Manager

The HyDraw[®] Property Manager displays assigned properties of the selected items, such as symbols, ports, connection lines, envelope, sub-systems and systems. Search the component or model code with given inputs in the Fetch Model Data. Configure your own design requirements and save the data into the library.

The screenshot shows the HyDraw CAD 2019 interface with a hydraulic circuit diagram and the HyDraw Property Manager window open on the right. The circuit diagram includes a pump (P1), a pressure gauge (G1), a pressure relief valve (RV1), a directional control valve (V1), and two cylinders (C1, C2). The Property Manager window displays the following information:

ITEM ID	QTY	MODEL CODE	DESCRIPTION	MANUFACTURER
1	3	DYN-CP-FP30ASAE	PRESSURE GAGE, 0-5000 PSI	DYNAMIC
2	1	MP100	PUMP MOTOR ASSEMBLY	CUSTOM
3	1	TR-20	HOSE	YUEN-INDIA
4	1	PS0-100	CLUTCH STRAINER	EATON
5	2	AS48P2-A	DIRECT ACTING PRESSURE RELIEF VALVE	PARNER
6	1	CH3AKAN	CHECK VALVE	EATON
7	1	4WE6.6X/EV-200VH	DIRECTION CONTROL VALVE	HYDAC
8	1	3AG-3000P020	FILTER	EATON
9	1	SD10-51-0M4	NEEDLE VALVE	HYDAC
10	1	LDN1	PLUG & TEMPERATURE SWITCH	YUEN-INDIA
11	1	BR10	FILLER/BREAHER	YUEN-INDIA
12	1	PH0107022	BLACK PLATING CONNECTOR	BOSCH REINROTH

ITEM ID	PORT TYPE	DESCRIPTION	PORT SIZE
BR, C, LVL, R	SAE O-RING	#4 SAE	#4 SAE
MC, MP, HR	SAE O-RING	#4 SAE	#4 SAE
PL, PL, PR1, T	SAE O-RING	#8 SAE	#8 SAE
TR1	SAE O-RING	#10 SAE	#10 SAE

NET NAME	NET LIST	NET PRESSURE (PSI)
NET-1	MC, R-2, C	3000
NET-2	P-1, T, SA-2	2500
NET-3	P-2, PL, PR, SA-1	2500
NET-4	HR, 6-2, R, SB-1	2000
NET-5	P-1, T-8	2500
NET-7	Q-1, SB-2, T-4	1400

FUNCTION	1-DV2	1-DV2	HOSE ID	QUANTITY	DESCRIPTION
CYLINDER EXT	<input type="checkbox"/>	<input type="checkbox"/>	3	1	HOSE
CYLINDER INT	<input type="checkbox"/>	<input type="checkbox"/>			

HYDRAW PROPERTY MANAGER

Selected Item System

Exclude from Parts List

Symbol

Item ID: 7
 Assembly ID: Ballon-Steel
 Display Setting: Circle

Design requirements

Flow (gpm): 6
 Pressure (psi): 3000

Model data

Model Code: 4WE6.6X/EV-200VH4
 Model Family: 4WE6
 Part Number: 611248
 Description: Direction Control Valve
 Manufacturer: Hydac
 Cost: 27
 Assembly Cost: 5
 List Price: 236
 Rated Flow (gpm): 21
 Pressure Loss @ Rated Flow: 145
 Rated Pressure (psi): 5000
 Cavity-Face/Port/Interface: D03
 Malfunction Flow (gpm): 21
 Voltage: 230
 Frequency: 50
 Bolt Shoulder Height (in): 1.4
 Installation Torque (Steel): 5.9 lb-ft / 8 Nm
 Installation Torque (Aluminum): 5.9 lb-ft / 8 Nm
 Catalog Number: RE 23178-08.08

Accessories

12 (R51017022)

Documents

Data Sheet Documents/Industrial/Revoth/

CAD Files

Valve Models D11W-C-AC-P.st

Display assigned properties of the selected symbol using the HyDraw Property Manager

1. Open HyDraw Property Manager

- Click **Circuit** >  on the HyDraw® CAD 2019 ribbon menu.

The HyDraw Property Manager dockable window displays and docks on the right side of the screen.

*The HyDraw Property Manager displays two tabs, **Selected Item** and **System**.*

Dock HyDraw Property Manager

- To move the Property Manager window, select it using the caption bar, then drag and dock it to the desired location.

HyDraw stores the information about the docking location of the Property Manager

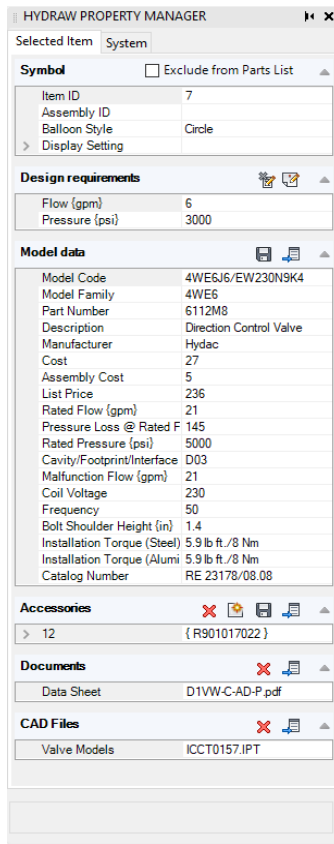

The screenshot shows the HyDraw Property Manager window with the following sections:

- Symbol**: Includes a checkbox for "Exclude from Parts List".
- Design requirements**: Includes fields for Flow (gpm) = 6 and Pressure (psi) = 3000.
- Model data**: Includes fields for Model Code (4WE6J6/EW230N9K4), Model Family (4WE6), Part Number (6112M8), Description (Direction Control Valve), Manufacturer (Hydac), Cost (27), Assembly Cost (5), List Price (236), Rated Flow (gpm) (21), Pressure Loss @ Rated F (145), Rated Pressure (psi) (5000), Cavity/Footprint/Interface (D03), Malfunction Flow (gpm) (21), Coil Voltage (230), Frequency (50), Bolt Shoulder Height (in) (1.4), Installation Torque (Steel) (5.9 lb ft./8 Nm), Installation Torque (Alumi) (5.9 lb ft./8 Nm), and Catalog Number (RE 23178/08.08).
- Accessories**: Includes a field for "12" with a list of accessories "{ R901017022 }".
- Documents**: Includes a field for "Data Sheet" with the file "D1VW-C-AD-P.pdf".
- CAD Files**: Includes a field for "Valve Models" with the file "ICCT0157.IPT".

HyDraw Property Manager

Selected Item tab

The Selected Item tab page displays the properties of the selected component.

The Selected Item tab page remains collapsed, if the item is not selected in the drawing.

Include in Parts List option is available for selection, when one or many Component Symbols selected in the drawing.

Note:

- Deselect **Exclude from Parts List** to exclude the selected item(s) from BOM.
- By default, the **Exclude from Parts List** option is deselected for all inserted symbols.
- Exclude accessories separately, if required.

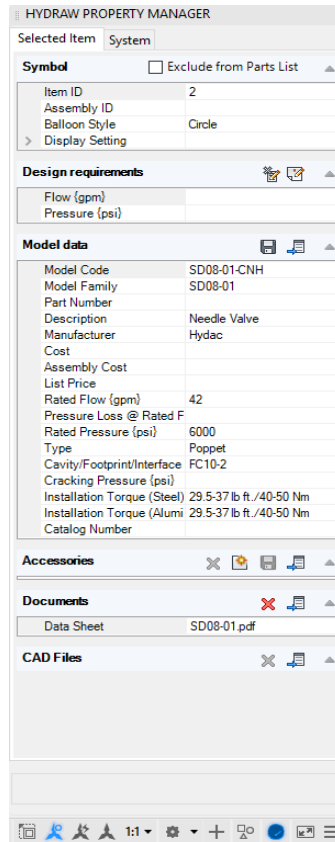

Selected Item tab page

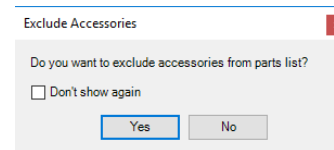

Exclude Accessories

System tab

The System tab page displays properties of the complete circuit.

It automatically expands all sections, whenever the schematic is opened in the drawing.

When the item is selected, or the schematic is open, the respective menu bar expands and the assigned values display.

When the item is selected in the component/external ports/envelopes/sub-systems, selected item displays in the drawing by **zoom to extents** selection.

Click  to expand/collapse.

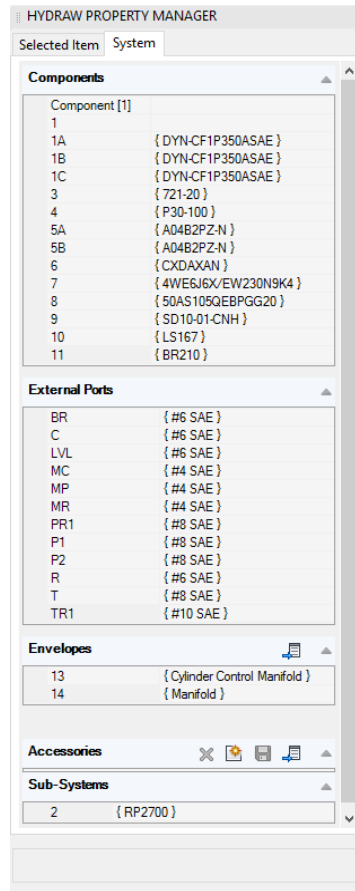

System tab page

2. Load HyDraw Property Manager on Startup

Select **Circuit** >  in the HyDraw® CAD 2019 ribbon menu.

1. Click the **Misc.** tab.
2. Select the **Property manager** checkbox from the Load on startup section.

Subsequently, the Property Manager opens and docks at its previous location.

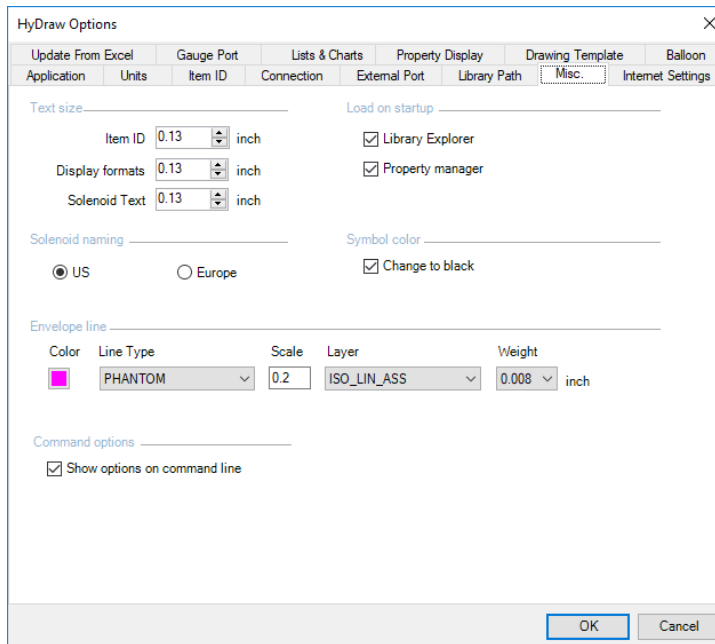

The screenshot shows the 'HyDraw Options' dialog box with the 'Misc.' tab selected. The dialog has a title bar with 'HyDraw Options' and a close button. Below the title bar is a tabbed interface with tabs for 'Update From Excel', 'Gauge Port', 'Lists & Charts', 'Property Display', 'Drawing Template', and 'Balloon'. The 'Misc.' tab is active, showing various settings. The 'Text size' section has three spinners for 'Item ID', 'Display formats', and 'Solenoid Text', all set to '0.13' inch. The 'Load on startup' section has two checked checkboxes: 'Library Explorer' and 'Property manager'. The 'Solenoid naming' section has two radio buttons: 'US' (selected) and 'Europe'. The 'Symbol color' section has a checked checkbox for 'Change to black'. The 'Envelope line' section has five fields: 'Color' (magenta), 'Line Type' (PHANTOM), 'Scale' (0.2), 'Layer' (ISO_LIN_ASS), and 'Weight' (0.008 inch). The 'Command options' section has a checked checkbox for 'Show options on command line'. At the bottom right are 'OK' and 'Cancel' buttons.

HyDraw Options: Misc.

8. HyDraw Options

Customize HyDraw® settings, such as Application, Units, Item ID, Connection, External Port, Lists & Charts, Library Path, Misc., Internet Settings, Update from Excel, Gauge Port, Property Display, Drawing Template and Balloon.

1. Application

The Application option enables you to select one of the three applications: Hydraulic, Pneumatic, and Electrical.

1. Click the **Application** tab.

The Application tab page displays.

2. Select the required application: Hydraulic, Pneumatic, or Electrical.

The HyDraw Library Explorer search from local database works as per selected applications in the HyDraw Options.

The HyDraw Property Manager select model from local database and select accessories from library works as per selected application in the HyDraw Options.

3. Click **OK**.

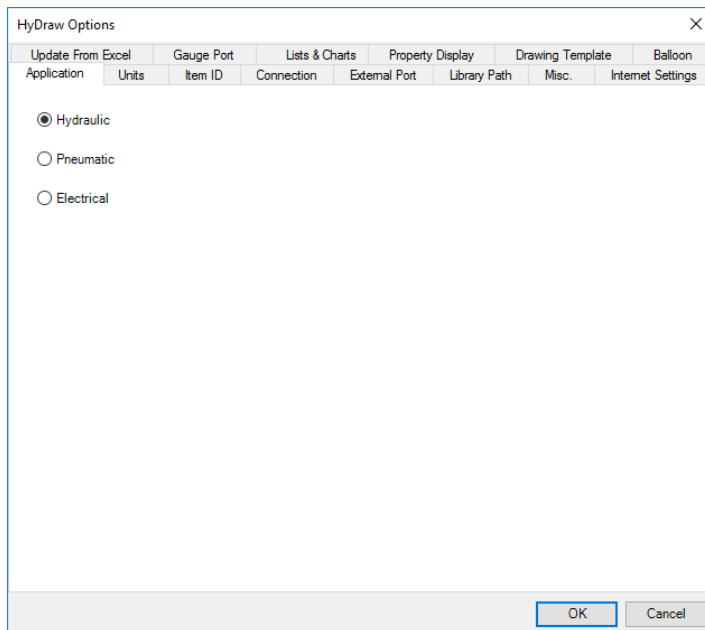

Application tab page

2. Units

The Units option enables you to select the unit for the selected application.

1. Click the **Units** tab.

The Units tab page displays.

2. Select the required drawing units (Imperial or Metric).

CAUTION!

Units should not be changed after symbol insertion.

3. Click Advanced Options.

Modify Units grid displays.

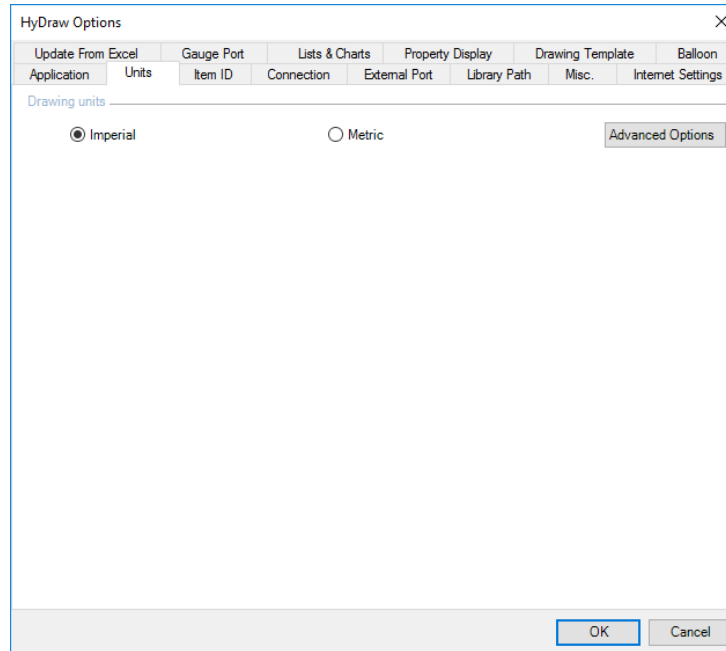

Units tab page

Units tab – Advanced Options

1. Configure each unit category by selecting the **Primary Unit**.
2. Select the **Display alternate unit** check box to display alternate unit along with the primary unit, if required.

The Alternate Unit column displays.

3. Configure the alternate units.
4. Click **Reset** button to restore the default units.
5. Click **OK** to apply and exit.

HyDraw Options

Update From Excel Gauge Port Lists & Charts Property Display Drawing Template Balloon
Application Units Item ID Connection External Port Library Path Misc. Internet Settings

Drawing units
 Imperial Metric Advanced Options

Modify Units

Unit Category	Primary Unit	Alternate Unit
Flow	gpm	LPM
Force	lbf	N
Frequency	Hz	RPM
Length	in	mm
Mass & Weight	lb	kg
Power	HP	KW
Pressure	psi	bar
Speed	ft/sec	m/sec
Temperature	°F	°C
Time	S	ms
Torque	Lbf-ft	Nm
Viscosity	cSt	St

Display alternate unit Reset

OK Cancel

Units tab – Display alternate unit

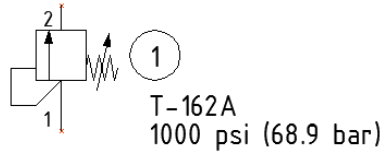

Displays Dual units in the drawing

3. External Port

Customize the external port in a circuit.

1. Click the **External Port** tab.

The External Port tab page displays.

2. Click an appropriate button to configure the external port either circle, oval, line, rectangle, square shape or Custom shape.

The respective shapes display in the port preview section of the HyDraw® Library Explorer window and can be inserted on the envelope line of the circuit.

When you select the custom shape, then all the custom shapes present in the library will display in the port preview section of the HyDraw Library Explorer window.

3. Select the shape in the **Default symbol for automatic insertion on envelope** drop down to insert automatically when an envelope intersects with the connection line.
4. Click **OK** to apply and exit.

Note:



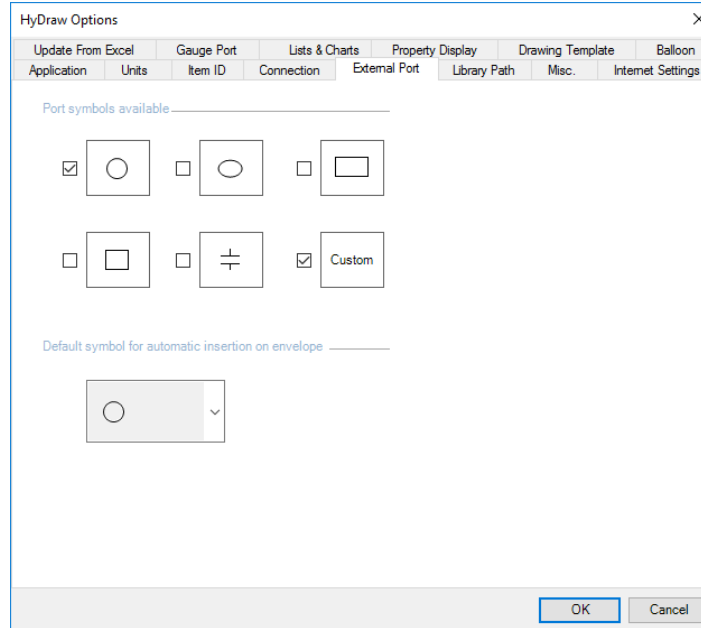



For adding custom shape to the HyDraw library refer Ch83.



External Port tab page

4. Lists & Charts

Customize the Parts List format

1. Click the **Lists & Charts** tab of HyDraw® options to select **Parts list**.
2. To rename a selected format, type the new name in the text box and then click .
3. To add a new format, type the new name in the text box and then click  below the textbox.
4. To delete a selected format, click  below the textbox.
5. To move up, select the item and click .
6. To move down, select the item and click .
7. To delete a property, click .
You cannot delete property item ID.
8. To add Parts list columns, click .
The Select Parts List Columns dialog box displays.
9. To include Quantity column, select the Quantity check box in the miscellaneous section.
10. Select the required properties and click **OK**.

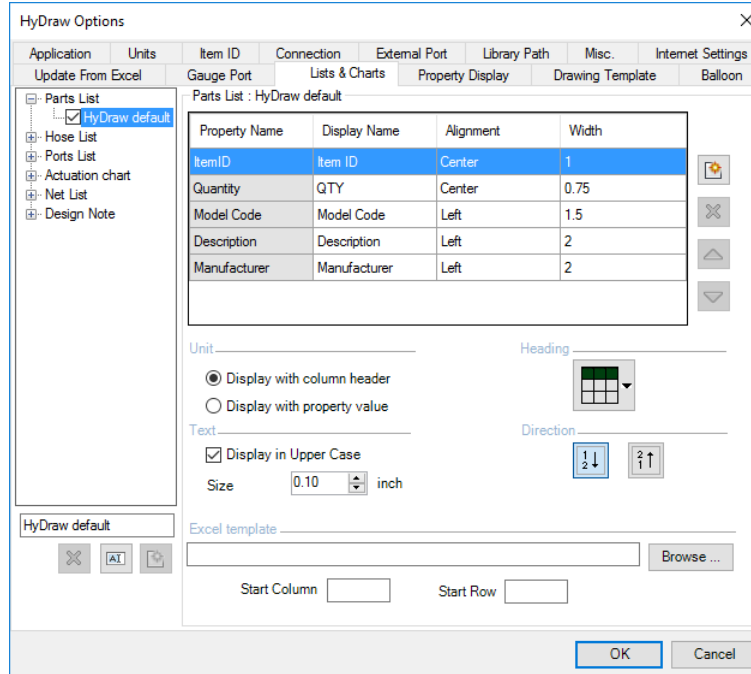

Parts List tab page

The selected properties are displayed in the Parts List tab page- Configure columns.

Unit: The Display with column header option shows the unit in the column header of the parts list column.

The Display with property value option shows the unit with the property value of each row.

Text: The Display in Upper Case option shows the list in the upper case. Also, you can change the text size of the list.

Heading: The Heading drop-down option selects the list header direction. For example, top, bottom or none.

Direction: Sort the list in an ascending or descending order.

11. Select the **Browse** button to export the Parts list in the Excel template format. Select the starting rows and columns of the given template.
12. Click **OK**.

The selected properties are displayed in a tabular form when the Parts list is created in the drawing.

Note:

To learn more about Parts List, refer Chapter 58.

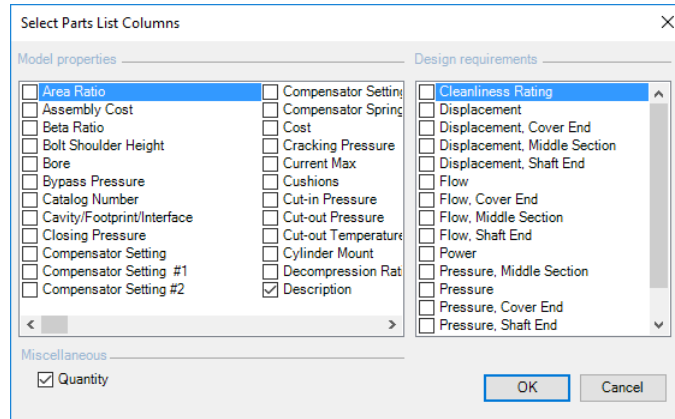







Select Parts List Columns

Hose List

Customize the Hose List format.

1. Click the **Lists & Charts** tab of HyDraw® Options and select **Hose List**.

The Hose List tab page displays.

2. To rename a selected format, type the new name in the text box and then click .
3. To add a new format, type the new name in the text box and then click  below the textbox.
4. To delete a selected format, click  below the textbox.
5. To move up, select the item and click .
6. To move down, select the item and click .
7. To delete a property, click .

You cannot delete the property name of the Item ID.

8. Click  to add Hose list columns.

The Select Hose List columns checklist box displays.

9. Select the required properties and click **OK**.

The selected properties are displayed in the Hose List tab page- Configure columns.

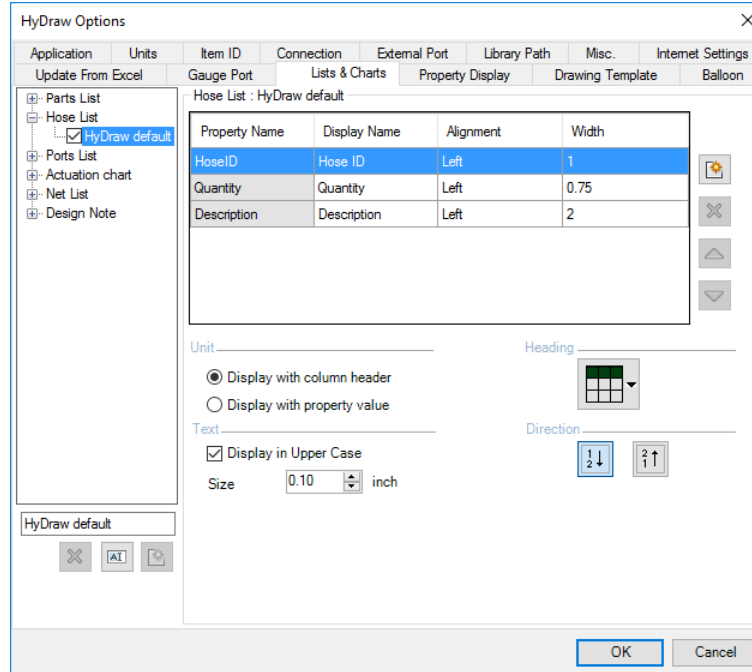

Hose List tab page

Unit: *The Display with column header option shows the unit in the column header of the parts list column. The Display with property value option shows the unit with the property value of each row.*

Text: *The Display in Upper Case option shows the list in the upper case. Also, you can change the text size of the list.*

Heading: *The Heading dropdown selects the list header direction. For example, top, bottom or none.*

Direction: *Sort the list in an ascending or descending order.*

10. Click **OK**.

The selected properties are displayed in a tabular form when the Hose list is created in the drawing.

Note:







To learn more about Hose List, refer Chapter 60.

Ports List

Customize the Ports List format.

1. Click the **Lists & Charts** tab of HyDraw Options to select **Ports List**.

The Ports List tab page displays.

2. To rename a selected format, type the new name in the text box and then click .
3. To add a new format, type the new name in the text box and then click  below the textbox.
4. To delete a selected format, click  below the textbox.
5. To move up, select the item and click .
6. To move down, select the item and click .
7. To delete a property, click .

You cannot delete Property Name of Item ID.

8. Click  to add port list columns.

The Select Ports List columns checklist box displays.

9. Select the required properties and click **OK**.

The selected properties are displayed in the Ports List tab page- Configure columns.

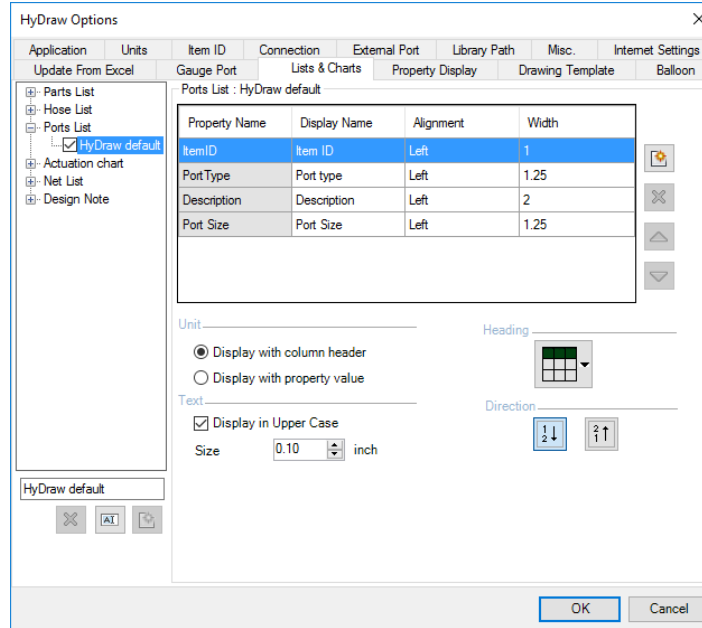

Ports List tab page

Unit: *The Display with column header option shows the unit in the column header of the parts list column. The Display with property value option shows the unit with the property value of each row.*

Text: *The Display in Upper Case option shows the list in the upper case. Also, you can change the text size of the list.*

Heading: *The Heading dropdown selects the list header direction. For example, top, bottom or none.*

Direction: *Sort the list in an ascending or descending order.*

10. Click **OK**.

The selected properties are displayed in a tabular form when the Ports list is created in the drawing.

Note:





To learn more about Ports List, refer Chapter 59.

Actuation Chart

Customize the Actuation Chart format.

1. Click the **Lists & Charts** tab of HyDraw Options and select **Actuation chart**.

The Actuation chart tab page displays.

2. To rename a selected format, type the new name in the text box and then click .
3. To add a new format, type the new name in the text box and then click  below the textbox.
4. To delete a selected format, click  below the textbox.
5. To move up, select the item and click .
6. To move down, select the item and click .
7. Select the required properties and click **OK**.

Text: The *Display in Upper Case* option shows the list in the upper case. Also, you can change the text size of the list.

Heading: The *Heading* dropdown selects the list header direction. For example, top, bottom or none.

Direction: Sort the list in an ascending or descending order.

8. Click **OK**.

The selected properties are displayed in a tabular form when the Actuation list is created in the drawing.

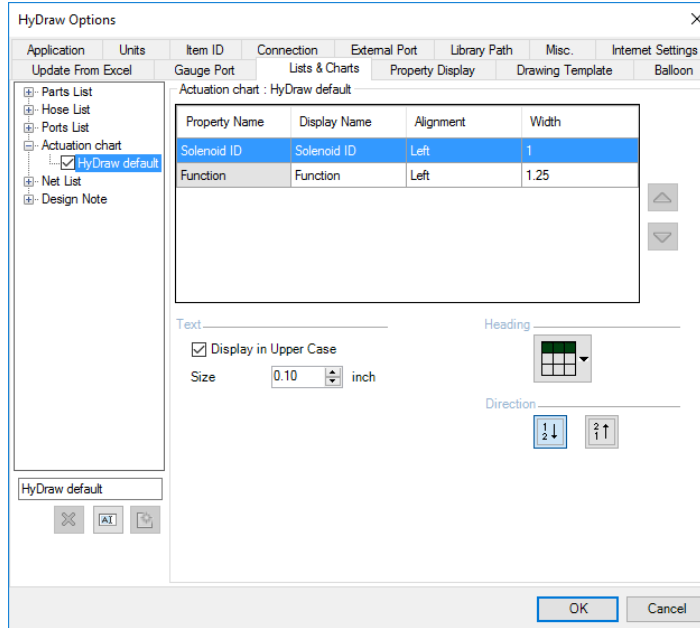





Actuation Chart tab page

Net List

Customize the Net List format.

1. Click the **Lists & Charts** tab of HyDraw Options to select **Net List**.

The Net List tab page displays.

2. To rename a selected format, type the new name in the text box and then click .
3. To add a new format, type the new name in the text box and then click  below the textbox.
4. To delete a selected format, click  below the textbox.
5. To move up select the item and click .
6. To move down select the item and click .
7. Select the required properties and click **OK**.

Text: The *Display in Upper Case* option shows the list in the upper case. Also, you can change the text size of the list.

Heading: The *Heading* dropdown selects the list header direction. For example, top, bottom or none.

Direction: Sort the list in an ascending or descending order.

The selected properties are displayed in a tabular form when the Net list is created in the drawing.

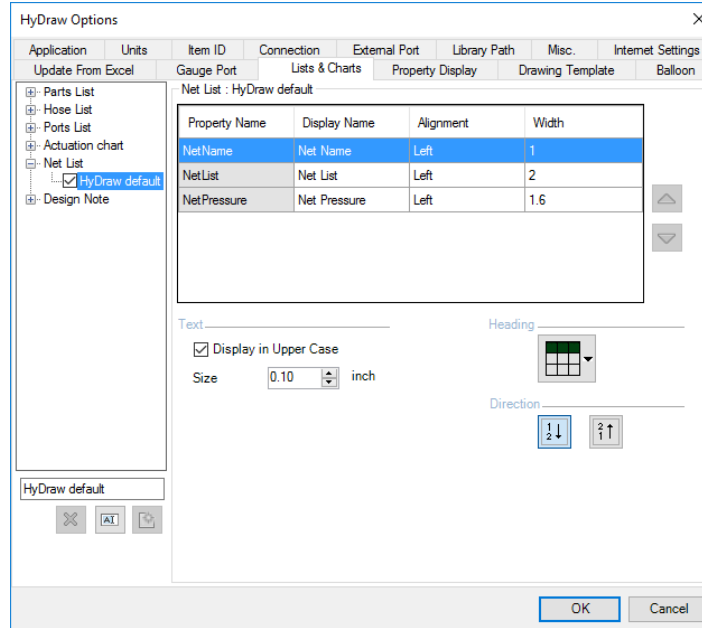





Net List page

Design Note

Customize the Design Note List format.

1. Click the **Lists & Charts** tab of HyDraw Options to select **Design Note**.

The Design Note page displays.

2. To rename a selected format, type the new name in the text box and then click .
3. To add a new format, type the new name in the text box and then click  below the textbox.
4. To delete a selected format, click .
5. To move up select the item and click .
6. To move down select the item and click .
7. Select the required properties and click **OK**.

Text: The Display in the Upper-Case option shows the list in the upper case. Also, you can change the text size of the list.

Heading: The Heading dropdown selects the list header direction.

For example, top, bottom or none.

Direction: Sort the list in an ascending or descending order.

The selected properties are displayed in a tabular form when the Design Note list is created in the drawing.

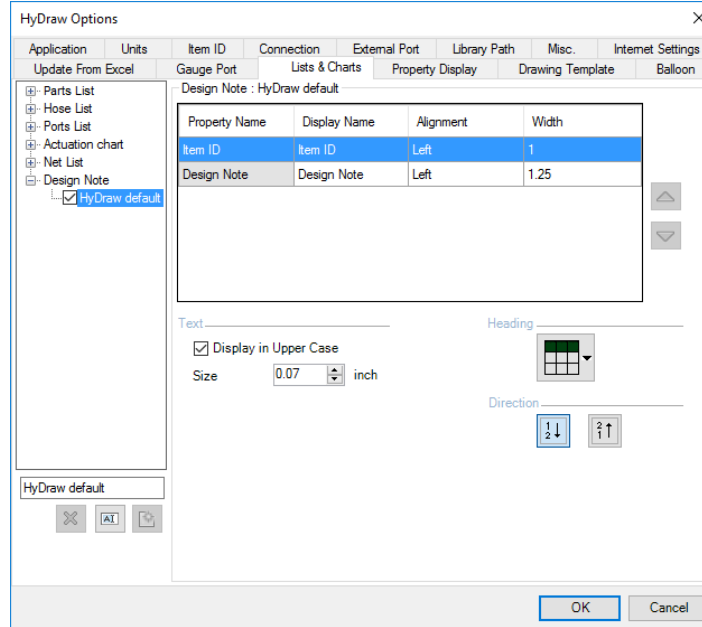

Design Note page

5. Library Path

Multiple users have easy access to the library and components data from a common source over a network.

1. Click the **Library Path** tab of HyDraw® Options.
The Library Path tab page displays.
2. Select the **Local Library** option.
3. Select the **Enable modification** check box to modify library.
The Modification menus are visible in the HyDraw Property Manager.
4. Click Browse...
5. Navigate to the folder where the HyDraw® library data is stored.
6. Repeat above steps for each of the specified HyDraw library paths.
7. Click **OK**.
All the HyDraw library paths are configured.
8. Select the **Corporate Library** option to configure second library path of your common Network library and repeat steps 3 to 7, if required.

Data Library: This section specifies the folder path that contains component data, library listing data, and manifold manufacturing estimation data.

Symbol Library: This section specifies the folder path that contains all libraries.

Sub-Systems: This section specifies the folder path that contains user-created circuit drawings and its menu data.

The screenshot shows the 'HyDraw Options' dialog box with the 'Library Path' tab selected. The dialog has a title bar with a close button (X) and a menu bar with options: Update From Excel, Gauge Port, Lists & Charts, Property Display, Drawing Template, and Balloon. Below the menu bar is a sub-menu bar with options: Application, Units, Item ID, Connection, External Port, Library Path (selected), Misc., and Internet Settings. The main area is divided into two sections: 'Local Library' and 'Corporate Library'. The 'Local Library' section is selected with a radio button and includes a checked 'Enable modification' checkbox. It has three rows: 'Data' with the path 'C:\VEST\HyDraw Library2019\Data' and a 'Browse...' button; 'Symbols' with the path 'C:\VEST\HyDraw Library2019\Symbol Library' and a 'Browse...' button; and 'Sub-Systems' with the path 'C:\VEST\HyDraw Library2019\SubSystems' and a 'Browse...' button. The 'Corporate Library' section is unselected and has an unchecked 'Enable modification' checkbox. It also has three rows for 'Data', 'Symbols', and 'Sub-Systems', each with a 'Browse...' button. At the bottom right are 'OK' and 'Cancel' buttons.

Library Path tab page

6. Misc.

Configure text size, envelope line, symbol color, and solenoid naming convention for the US and Europe pattern. It also enables you to load the HyDraw® Library Explorer and the HyDraw Property Manager at startup.

Click **Misc.** to display the tab page.

The screenshot shows the 'HyDraw Options' dialog box with the 'Misc.' tab selected. The 'Text size' section has three spinners: 'Item ID' (0.13 inch), 'Display formats' (0.13 inch), and 'Solenoid Text' (0.13 inch). The 'Load on startup' section has two checked checkboxes: 'Library Explorer' and 'Property manager'. The 'Solenoid naming' section has 'US' selected with a radio button and 'Change to black' checked. The 'Envelope line' section has 'Color' set to magenta, 'Line Type' to 'PHANTOM', 'Scale' to 0.2, 'Layer' to 'ISO_LIN_ASS', and 'Weight' to 0.008 inch. The 'Command options' section has 'Show options on command line' checked. 'OK' and 'Cancel' buttons are at the bottom.

Misc. tab page

Text Size

1. In the Text size group box, select the appropriate text size from the respective list box for item ID and display properties.
2. Click **OK** to effect the changes to the properties in the drawing.

This screenshot is identical to the previous one, but a red rectangular box highlights the 'Text size' section, which includes the 'Item ID', 'Display formats', and 'Solenoid Text' spinners.

Text size section

Envelope Line

1. In the Envelope line section, select the appropriate line pattern from continuous, phantom, and hidden list box options.
2. Click the **Color** button to open the color box and select the required color.
3. Enter the appropriate scale in the **Scale** textbox.
4. Click the combo box to select a layer from 0, Def points, ISO_LIN_ASS, ISO_LIN_FLU, ISO_LIN_HAT, ISO_LIN_UNI, ISO_TEX_DES, ISO_TEX_DES_EU, ISO_TEX_DES_US, ISO_TEX_IDE, ISO_TEX_POS, PORT_SYM.
5. In the **Weight** textbox, enter the appropriate weight of line.
6. Click **OK** to effect the changes in the library.

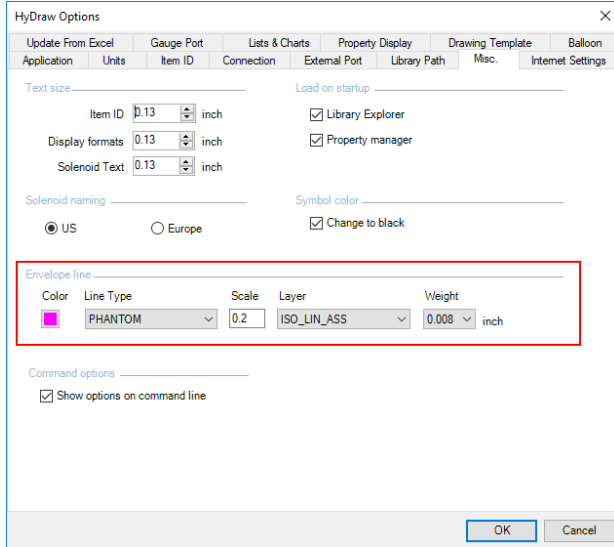

Envelope line section

Load on startup

The Library Explorer and Property Manager can be loaded to HyDraw on startup.*

1. In the Load on startup group box, select the application you want to use for loading on startup.
The selected application loads and docks to the HyDraw drawing.
2. Click **OK** to effect the changes.

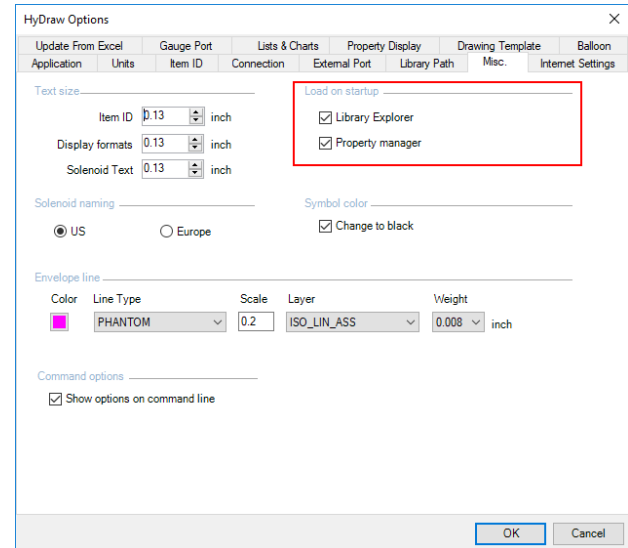

Load on startup section

Symbol Color

All symbols in the HyDraw® library are created with the ISO standard colors. You can also change the colors of these symbols to black.

Select Change to black in the Symbol color section.

1. Click OK to affect the changes in the drawing.

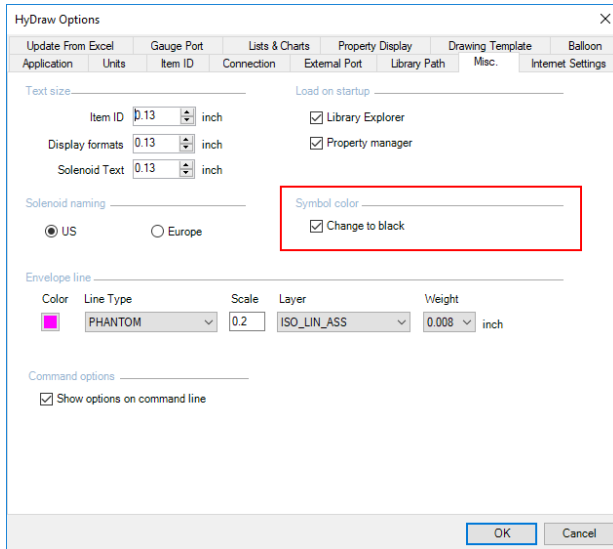

Symbol color section

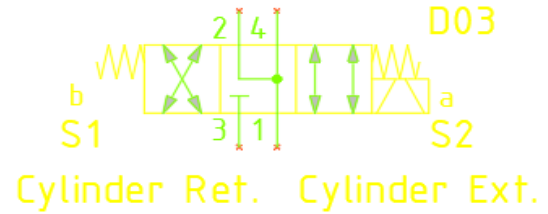

Colored Symbol

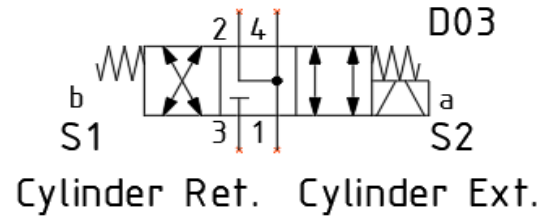

Black Symbol

Customize HyDraw Layer Properties

Click Drafting Ribbon > Layer Properties

The default HyDraw layers are listed in the dialog.

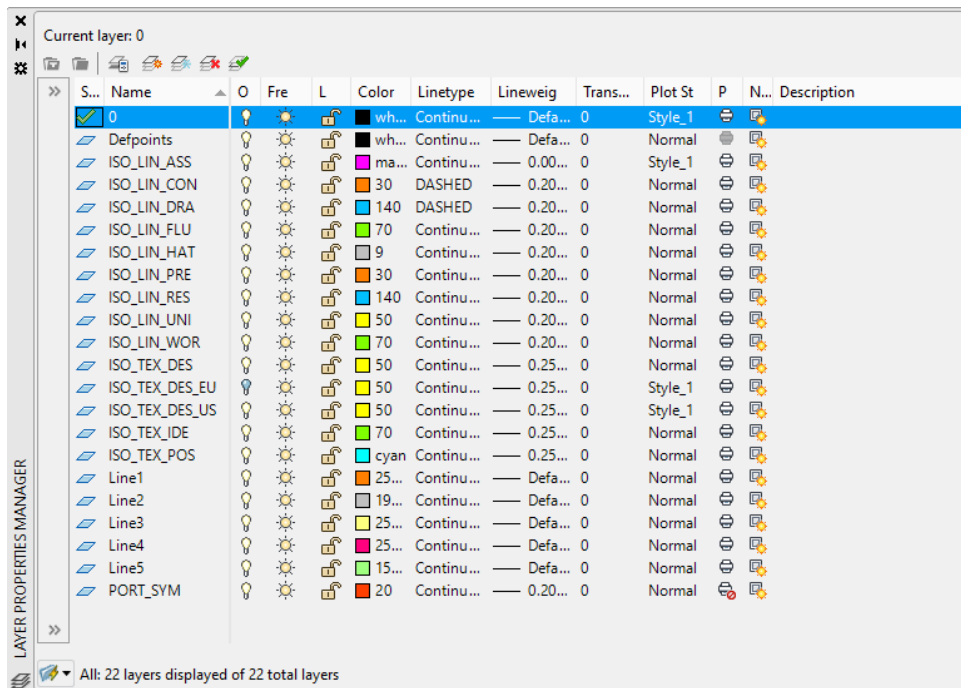

Layer Properties Manager

Solenoid Naming

Solenoid naming conventions for Directional Control Valve symbols are different for both US and Europe patterns. You can only view one naming convention for a pattern at a time.

1. Select the appropriate pattern in the Solenoid naming section.
The selected pattern will affect the change of solenoid naming of symbols in the HyDraw® drawing.
2. Click **OK** to affect the changes.

Solenoid naming section

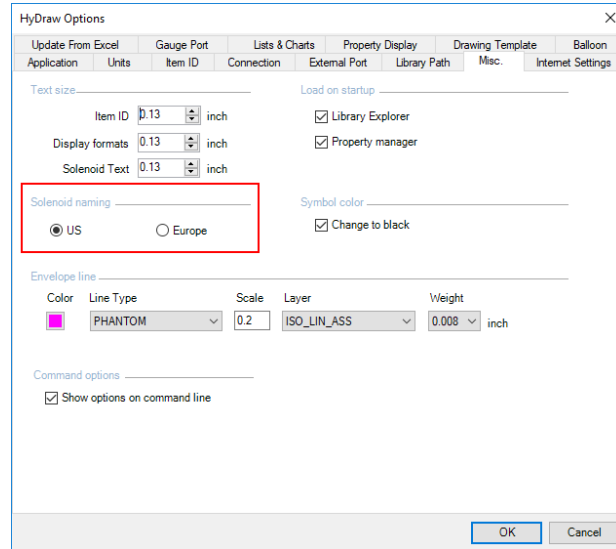
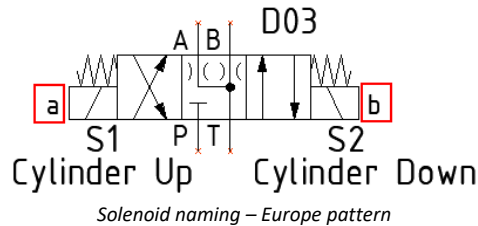
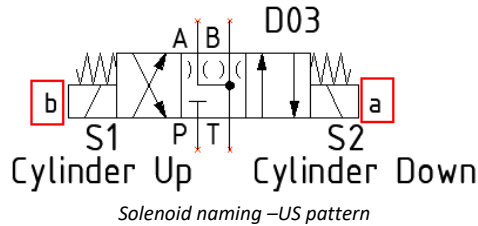

Solenoid naming

Command options

1. Select the **Show options on command line** check box, if you need to show the selection options on the command line.
2. Click **OK** to effect the changes.

Note:

If the *Show options on command line* option is deselected, only a few HyDraw® commands will display a dialog box.

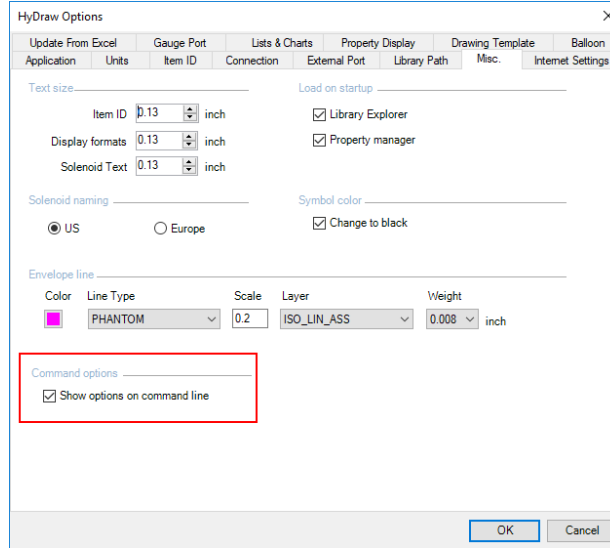

The screenshot shows the 'HyDraw Options' dialog box with the following settings:

- Update From Excel: Application
- Gauge Port: Units
- Lists & Charts: Item ID
- Property Display: Connection
- Drawing Template: External Port
- Balloon: Library Path
- Internet Settings: Mac.

Text size: Item ID 0.13 inch, Display formats 0.13 inch, Solenoid Text 0.13 inch

Load on startup: Library Explorer, Property manager

Solenoid naming: US, Europe

Symbol color: Change to black

Envelope line: Color (magenta), Line Type (PHANTOM), Scale (0.2), Layer (ISO_LIN_ASS), Weight (0.008) inch

Command options: Show options on command line

Buttons: OK, Cancel

Command options

7. Internet Settings

Configure the Internet connection for FluidPowerTools®.

1. Click **Internet Settings** in the Services tab on the HyDraw® CAD ribbon menu.

The Internet Settings of the HyDraw Options dialog box displays.

2. Configure the required settings.

Note:

Refer Chapter 75, Para 2 for detailed configuration settings.

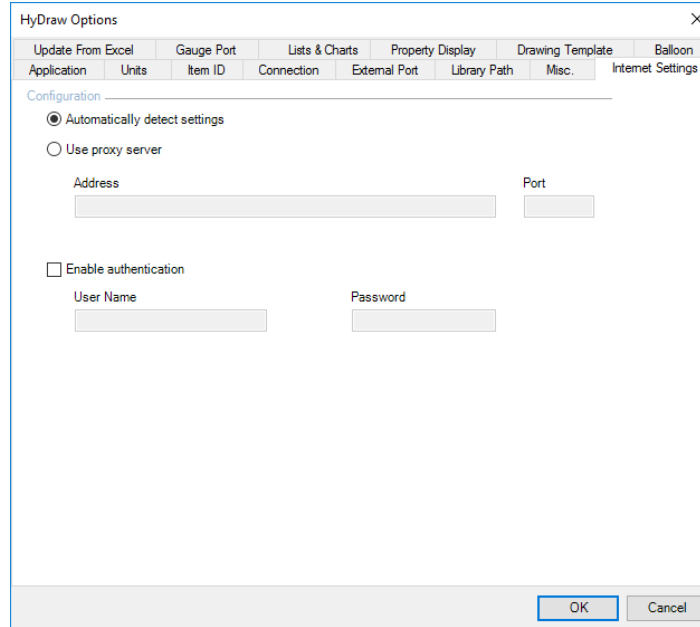

The screenshot shows the 'HyDraw Options' dialog box with the 'Internet Settings' tab selected. The dialog has a title bar with a close button (X) and a tabbed interface. The 'Internet Settings' tab is active, showing a 'Configuration' section with two radio buttons: 'Automatically detect settings' (selected) and 'Use proxy server'. Below these are input fields for 'Address' and 'Port'. There is also an 'Enable authentication' checkbox, which is unchecked, with corresponding 'User Name' and 'Password' input fields. At the bottom right, there are 'OK' and 'Cancel' buttons.

Update From Excel	Gauge Port	Lists & Charts	Property Display	Drawing Template	Balloon		
Application	Units	Item ID	Connection	External Port	Library Path	Misc.	Internet Settings

Configuration

Automatically detect settings

Use proxy server

Address Port

Enable authentication

User Name Password

OK Cancel

HyDraw Options – Internet Settings Tab

8. Update from Excel

Configure the Update from Excel settings for Update from Excel Interface.

1. Select **Update from Excel** from HyDraw® Options.
2. Browse the path of **My local Excel data** and select the ERP data.
3. Browse and select the Service URL for the **online Excel data**.
4. Search data by the **Model Code** or the **Part Number**.
5. Click **OK** to save the update from Excel settings and close HyDraw Options.

Note:

- To create the ERP configuration XML file, go to Start > All Apps > VEST > HyDraw Library Manager 2019 > HyDraw Update from Excel 2019.
- For more details on how to use the HyDraw Update from Excel 2019, refer to the HyDraw Library Manager 2019 User Manual.

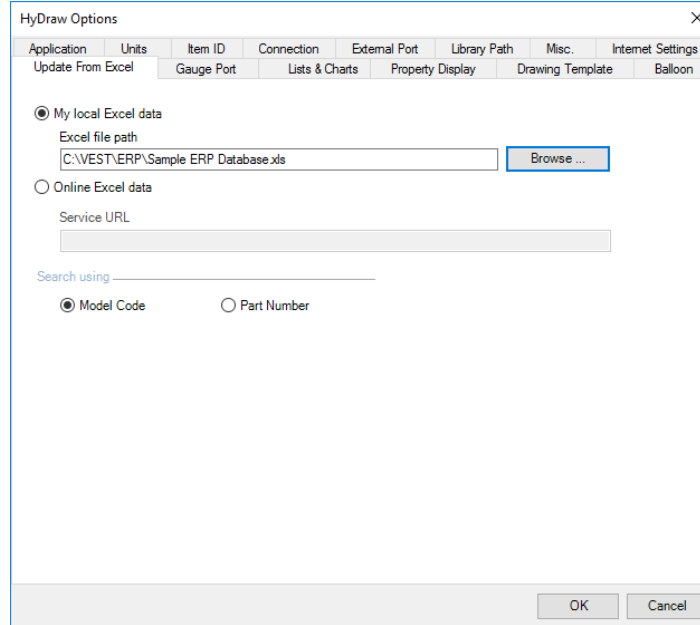

HyDraw Options – Update from Excel Settings

9. Connection Tab

Customize Connection properties for each connection line and configure Recommended velocity, Jumper, Dot (size) and Jumping Reference for the drawing.

1. Click the **Connection** tab.

The Connection tab page displays.

2. In the **Connection Properties** group box, the Pressure, Reservoir, Control, Drain, Suction or Working lines are by default locked for editing. Deselect **ISO**, if required to edit. The Name is not editable for these six lines. Modify all other custom connection line properties like Name, Type, Line Type, Scale, Layer, Weight and Color by selecting each cell.
3. Edit in place for **Name** and **Scale**.
4. Select the **Type** from Pressure, Tank, Pilot, Drain or Suction.
5. Select the **Line Type** from BYLAYER, CONTINUOUS, PHANTOM, HIDDEN, DASHED etc from the drop-down preview.
6. Select the Layer ISO_LIN_PRE, ISO_LIN_RES, ISO_LIN_CON, ISO_LIN_DRA, ISO_LIN_RES, ISO_LIN_WOR or any custom layer
7. Select **Weight** from BYLAYER or any available line weight.
8. Select **Color** from the drop down or pick from color palette.
9. Set the recommended velocity for Pressure and Return Line.
10. In the **Jumper** section, select the size of the jumper from large, medium, and small.
11. In the **Dot** section, select the size of the connection dot from large, medium, and small.

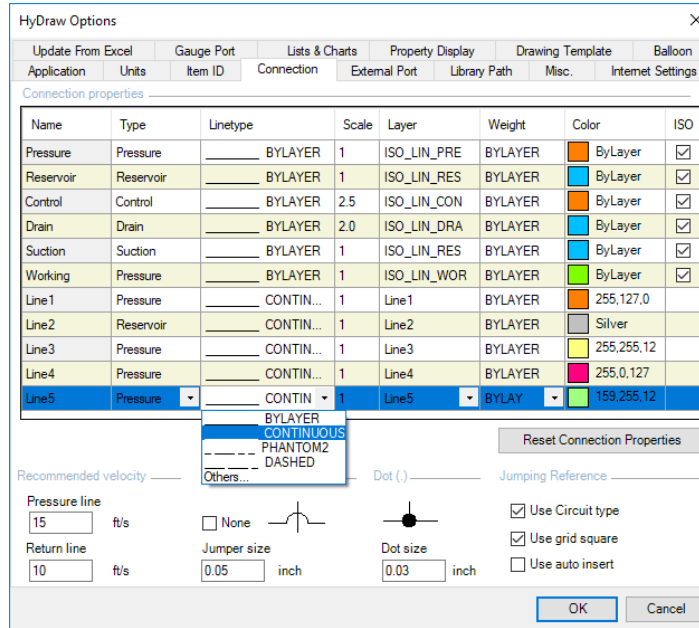

HyDraw Options – Connection Tab

Connection dot is automatically inserted when one line terminates on another.

12. In the Jumping Reference section,
 - Select **Use circuit type** to display Circuit type option in the Jumping Reference command.
 - Select **Use grid square** to display Grid square option in the Jumping Reference command.
 - Select **Use auto insert** to automatic insertion of jumping reference for the connection line.
13. Click the **Reset Connection Properties** button if you want to reset all the values to default values from the HyDraw Library database.
14. Click **OK** to apply and exit.

Note:

To add more custom connection lines,
Refer HyDraw Library Manager 2019 Help,
Chapter No. 29.

10. Item ID

Enclose the envelope ID, component ID, accessories ID, hoses ID, and sub-system ID.

1. Click the **Item ID** tab of HyDraw® Options.
The Item ID tab displays.
2. Select the **ISO 1219** numbering scheme or **Sequential Numbering**.
Enter the Item ID starting number and Group by component code or identical items for sequential numbering.
Select the separator and count, per requirement.
This helps in the identification of the component.
3. Select the **Same scheme as Components** option in the Hoses section to enable hoses to follow the numbering scheme. Else, provide separate numbering scheme for hoses.
4. Select the **As sub item of component** checkbox to number the accessory same as the sub-item of the component.
5. Select **Separator** and **Accessory ID** to define the accessory Item ID.
6. Select the **List component as first sub-item** checkbox to number the first sub-item.
7. Select the **Assembly ID** checkbox to display the Assembly ID in the drawing.
8. Select **Accessory Item ID** in the Display section to show the accessory item ID in the drawing.

HyDraw Options – Item ID Tab

9. Select **Stack horizontally** or **Stack vertically** to orient accessory IDs and its balloons with component Item IDs.
10. Click **OK** to save and exit.

11. Gauge Port

Configure the Gauge port settings.

1. Click the **Gauge port** tab of HyDraw Options.
The Gauge port tab page displays.
2. Configure the default gauge port type, size and prefix.
3. Set the **Gauge port insertion distance** default values in the External Port tab.
Else, set the locations in this tab.
4. Select the default symbols for the **Open** and **Close** options from the drop down.
5. Click **OK** to save and exit.

Note:

For more information, refer chapter No.16.

The screenshot shows the 'HyDraw Options' dialog box with the 'Gauge Port' tab selected. The dialog has a title bar with a close button (X) and a menu bar with the following items: Application, Units, Item ID, Connection, External Port, Library Path, Misc., Internet Settings, Update From Excel, Gauge Port, Lists & Charts, Property Display, Drawing Template, and Balloon. The 'Configuration' section includes a 'Type' dropdown menu set to 'SAE O-ring', a 'Prefix' text box containing 'G', and a 'Size' dropdown menu set to '#4 SAE'. The 'Location' section has a 'Distance from main port (X)' text box with '0.2' and 'inch' next to it, and a 'Connection distance (Y)' text box with '0.2' and 'inch' next to it. To the right of these text boxes is a diagram of a gauge port symbol with dimensions X and Y. The 'Symbol' section has two dropdown menus: 'Open' with a circle symbol and 'Close' with a circle containing an 'X' symbol. At the bottom right are 'OK' and 'Cancel' buttons.

HyDraw Options – Gauge Port

12. Property Display

Customize Show/Hide display format in the drawing.

1. Click **Property Display** tab of HyDraw Options.

The Property Display page displays.

2. Select/Deselect the display properties in following sections, Components, External Ports and Connections.

*Click **None**, to deselect all the display formats of Components, External Ports and Connections to Hide.*

Click **Select All**, to select all the display formats of Components, External Ports and Connections to Show.

3. Click **Reset**, if you want to update the list of display formats from the HyDraw Library database.
4. Click **OK** to save and exit.

Note:

The space between the displayable properties is automatically controlled.

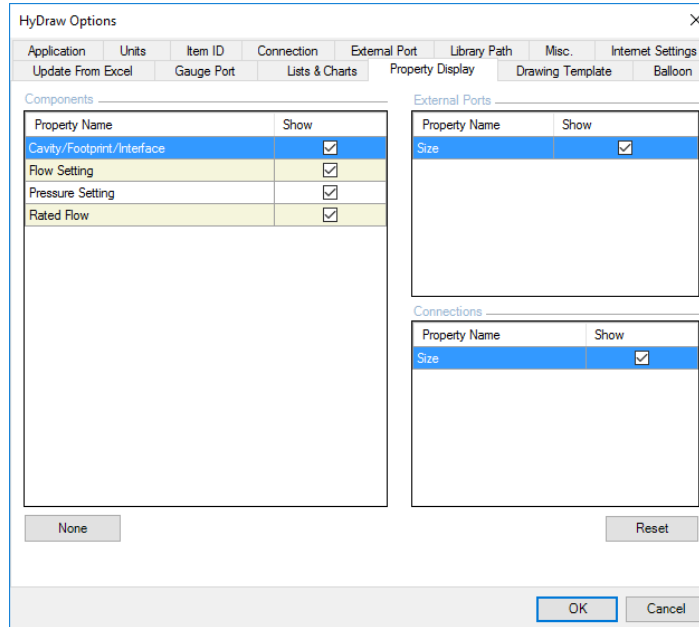

HyDraw Options – Property Display

13. Drawing Template

Assign Drawing templates to the Sheet size from the Template folder.

1. Click **Drawing Template** tab of HyDraw Options.
The Drawing Template page displays.
2. Click the **Browse** button to select the Drawing template path.
3. Assign Drawing template from file name drop-down as per the sheet size.
4. Click **OK** to save and exit.

Caution:

Define **Title Block** and **Border** name as per the title block and border name saved in the template.

Note:

Default Template path should be “C:\Users\User\AppData\Local\VEST\HyDraw CAD 2019\R2019\enu\Template”. You can also assign custom template path.

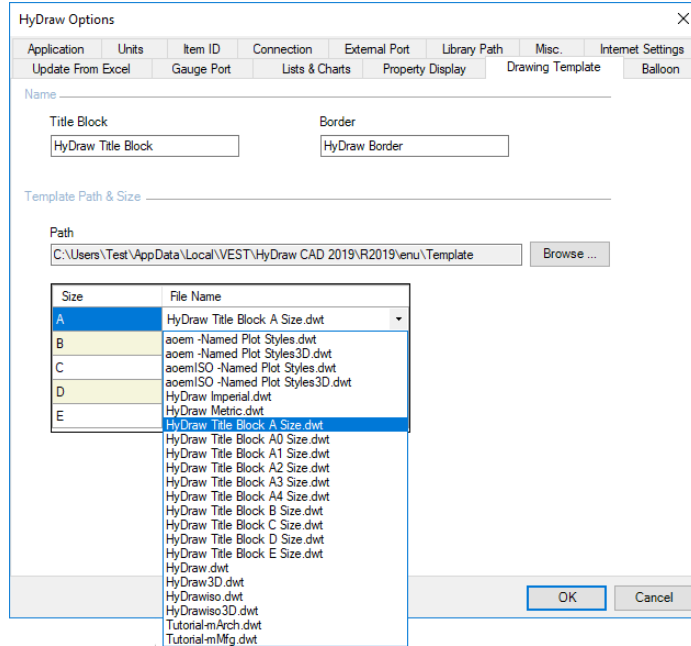

HyDraw Options – Drawing Template

14. Balloon

Configure the **Balloon** type.

1. Click the **Balloon** tab of HyDraw Options.
The Balloon tab page displays.
2. Select the default **Balloon type** for Component, Sub-System, Accessory and Hose.
3. Select the **No balloons on external ports** check box, if you don't want any balloon on the external port name.
4. Click **OK** to save and exit.

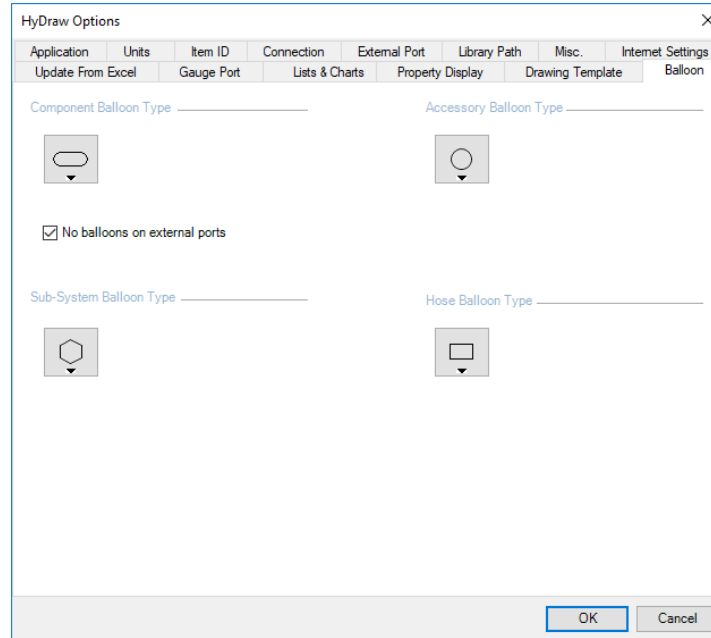

HyDraw Options – Balloon

Insert Symbols

The screenshot displays the HyDraw CAD 2019 software interface. The 'Insert' menu is open, showing a list of options for inserting symbols into a hydraulic schematic. The schematic in the center shows a hydraulic circuit with various components labeled with letters like P, S1, A, B, S2, and T. The 'HYDRAW LIBRARY EXPLORER' on the left shows a search for 'Component Type' and a list of hydraulic symbols. The bottom right shows a 'Parts List' and 'Accessories' panel.

9 Insert Symbol

10 Insert External Port

11 Insert Sub-Systems

12 Insert from Parts List

13 Insert Terminators

14 Insert Symbol Port

15 Insert Envelope

16 Insert Gauge Port

17 Insert Orifice Disc

18 Insert Jumping Reference

9. Insert Symbol

Search component type, search symbols, insert symbols, insert external ports, search sub-systems and insert sub-systems into the drawing.

The Insert Symbol command is on the Circuit tab of the HyDraw® CAD ribbon menu.

The Component library is a logically structured symbol library of hydraulic, pneumatic, and electrical systems.

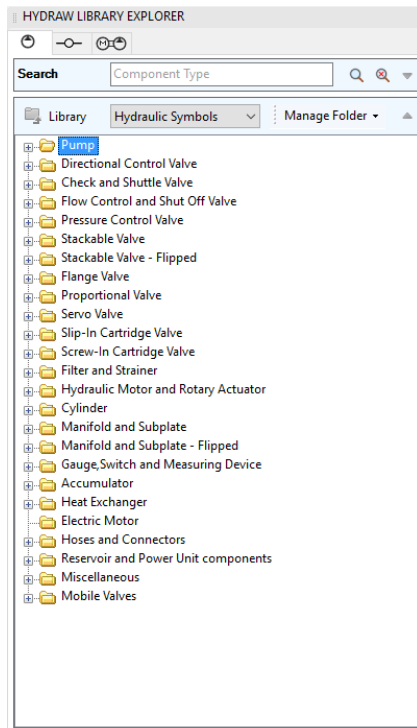

Logically structured Component Library

1. Search and Insert Symbol by Component type

1. Enter the required component type of symbol.
2. Click  search button.
3. Select the appropriate library and navigate to the required symbol.
4. Drag the symbol from the HyDraw* Library Explorer window on the drawing.

Alternatively:

1. Double click the symbol on HyDraw Library Explorer window.
Symbol preview appears on the drawing space.
The Specify insertion point prompt displays.
2. Specify the Insertion Point or Select Rotate/Flip option.
Rotate, Left/Right or Flip, Vertical/Horizontal.

The symbol is placed on the drawing.

Note:

You can also use wild characters Percent (%) or Asterisk (*) to search by component type.

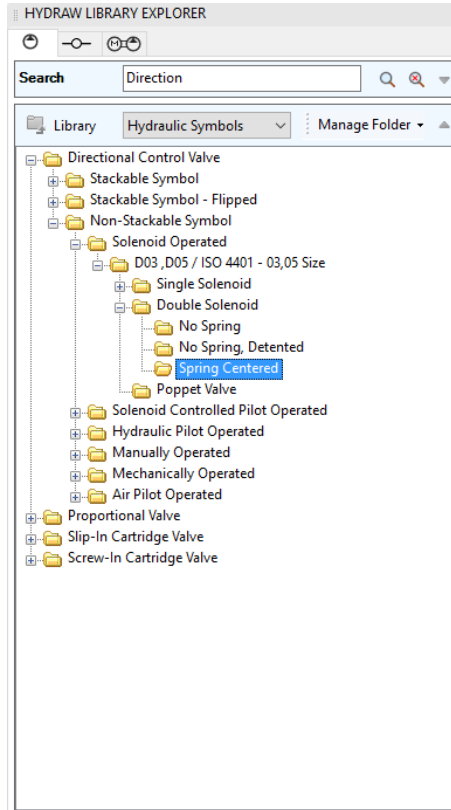

Search library by Component Type

Replace Symbol

1. Select the Symbol to replace in the drawing.
2. Select the **Replace symbol** check box in the HyDraw® Library Explorer.
3. Drag and drop the new symbol in the drawing.

Alternatively:

1. Double click the new symbol on HyDraw Explorer window.
 - Symbol preview appears on the drawing space.
 - The Specify insertion point prompt displays.
2. Specify the **Insertion Point** or Select **Rotate/Flip** option. Select Rotate **Left/Right** and/or Flip, **Vertical /Horizontal**.
 - The Symbol is replaced on the drawing.*

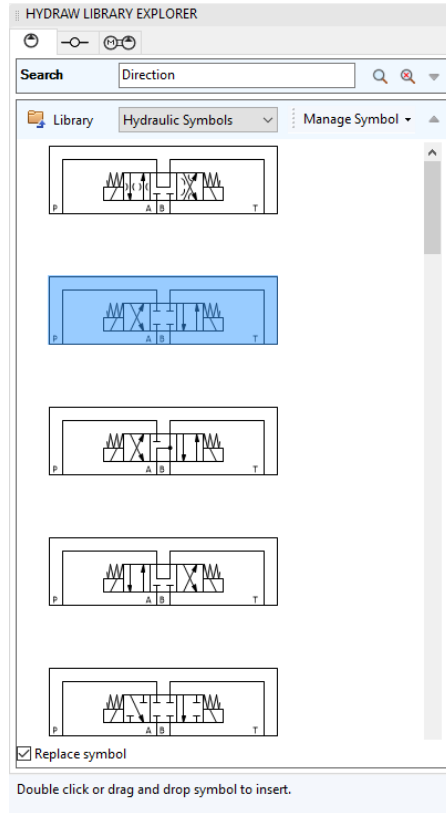

Replace Symbol from Library into drawing

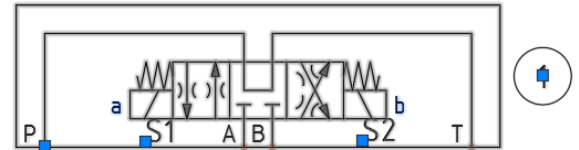

2. Insert a Symbol by Library

1. Select the appropriate library and navigate to the required symbol.
2. Drag the symbol from the HyDraw[®] Library Explorer window on the drawing.

Alternatively:

1. Double click the symbol on HyDraw Library Explorer window.

Symbol preview appears on the drawing space.

The Specify insertion point prompt displays.

Automatic ID is assigned to symbols based on the scheme set in HyDraw Options – Item ID tab.

2. Specify the **Insertion Point** or Select **Rotate/Flip** option. Select Rotate **Left/Right** and/or select Flip, **Vertical /Horizontal**.

The symbol is placed on the drawing.

Note:

Copied symbols also get automatic IDs based on the scheme set in HyDraw Options – Item ID tab.

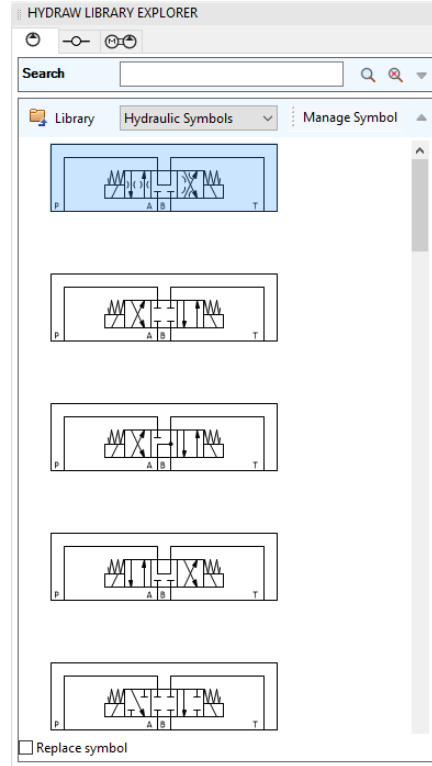

Double click or Drag and drop symbol from Library into the drawing

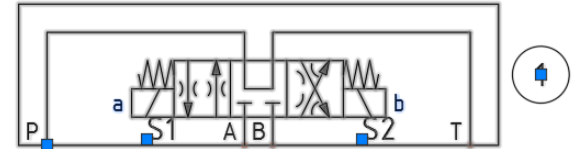

Replace Symbol

1. Select the Symbol to replace in the drawing.
2. Select the **Replace symbol** check box in the HyDraw Library Explorer.
3. Drag and drop the new symbol on the drawing.

Alternatively:

1. Double click the new symbol on HyDraw Explorer window.
Symbol preview appears on the drawing space.
The Specify insertion point prompt displays
2. Specify the **Insertion Point** or Select **Rotate/Flip** option. Select Rotate, **Left/Right** and/or select Flip, **Vertical /Horizontal**.
The Symbol is replaced on the drawing.

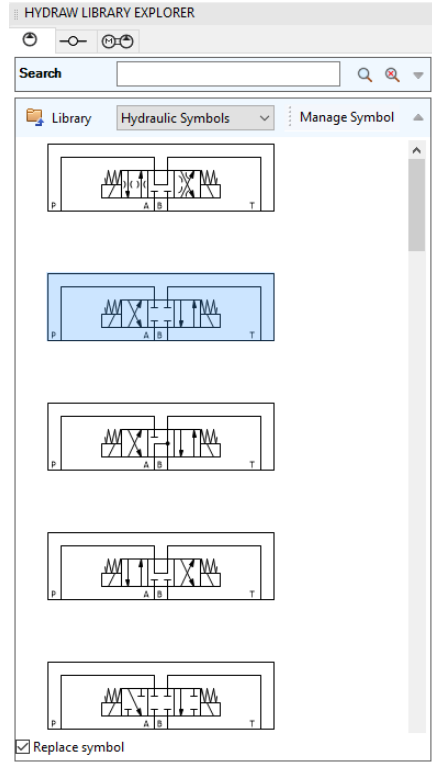

Replace Symbol from Library into the drawing

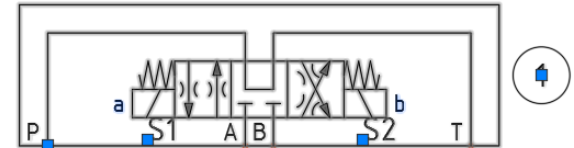

3. Search and Insert Symbol by Components

1. Click  button in the Search section.

The Search section page displays.

2. Select appropriate search database, My local database or FluidPowerTools.com database.

If the My local database option is selected, the program searches components in the user's local database.

*If the FluidPowerTools.com database option is selected, the program searches components by manufacturer as set in the **HyDraw CAD 2019 > Services > Data Access Settings***

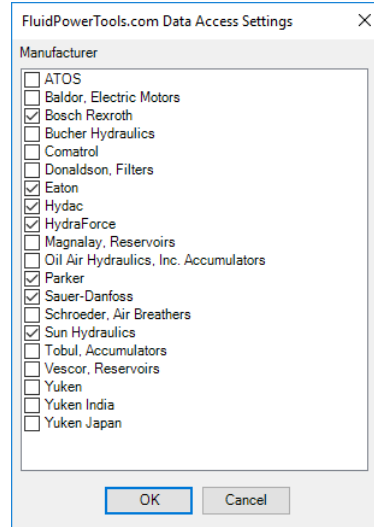

Services - Data Access Settings dialog box

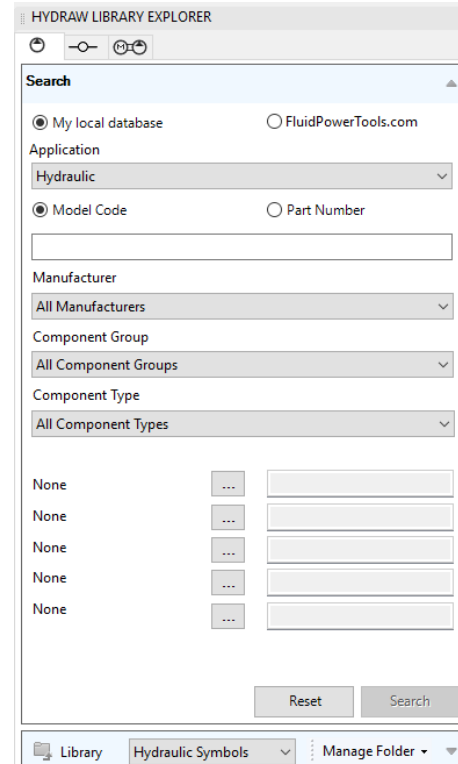

Default Search tab page

3. Select the required application, such as Hydraulic, Pneumatic or Electrical.
If the Application Type, Hydraulic, is selected, then the program searches only for components applicable to hydraulic.

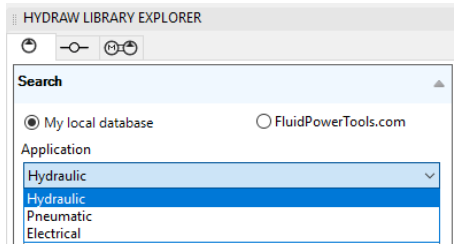

4. Enter the Model Code to search a particular component.
Or
Enter the Part Number to search a particular component, if *My local database* is selected.

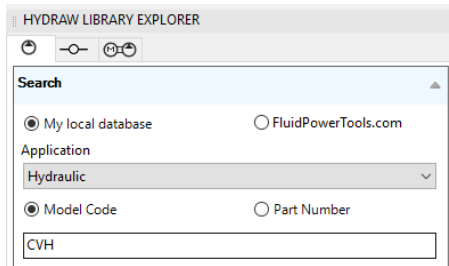

Enter Model Code

5. Select the manufacturer from the drop-down list, if *My local database* is selected.

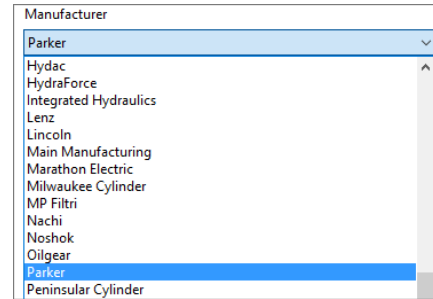

Manufacturer options

6. Select the appropriate component group from the drop-down list.

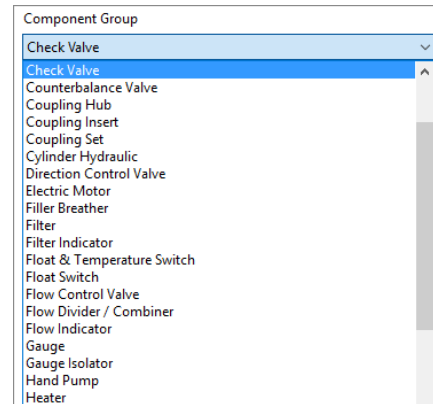

Component group options

7. Select the appropriate component type, if **All Component Groups** is selected in the component group.

Or

Select the component type as per selected component group.

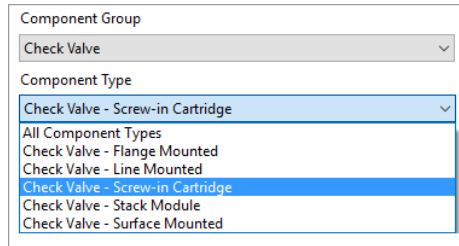

Component type selected as per component group selection

8. Define more criteria.

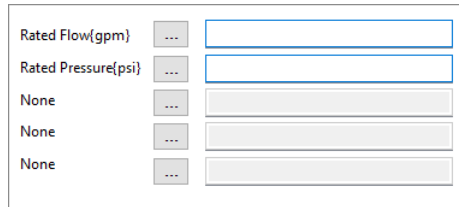

Define More Criteria options

- 8.1 For precise search, define custom search parameters by model properties.
- 8.2 Click to view the Select Property box, which displays common properties.

- 8.3 Select the property you want to assign.
- 8.4 Enter the property value, for example 10, or range, for example 10-20.

Property range must be separated by a hyphen (-).

9. Select Property.

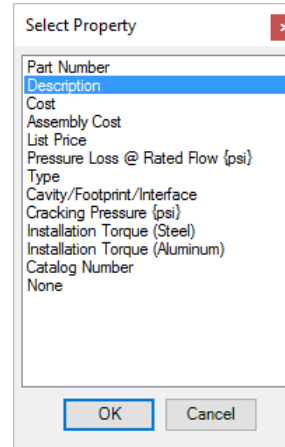

Select Property

10. Click the **Search** button.

All model codes or model family with assigned custom properties are displayed in the Search result pane.

HYDRAW LIBRARY EXPLORER

Search

My local database FluidPowerTools.com

Application
Hydraulic

Model Code Part Number

CVH

Manufacturer
Parker

Component Group
Check Valve

Component Type
Check Valve - Screw-in Cartridge

Rated Flow(gpm) ... 16

Rated Pressure(psi) ... 5000

None ...

None ...

None ...

Reset Search

Search Model code with precise criteria

11. Select the appropriate model code or model family in the preview pane.

The Search results are displayed in the pane.

HYDRAW LIBRARY EXPLORER

Search result

Available models

Model Code	Manufactu...	Description	Rated Flow...	Rat
CVH103P	Parker	Check Valve	16	5000
CVH121P-**	Parker	Check Valve	32	5000

Symbols

1 2

1 2

Replace symbol

Preview symbols

Filter Search Results

On mouse hover the property header, click  button to select the required property value.

The Available models display as per selected property value.

By default, all properties value displays in the available models.

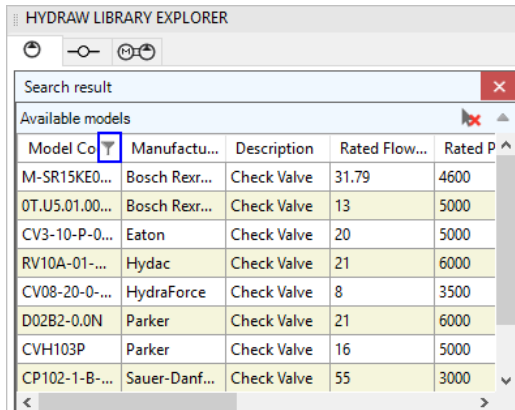

HYDRAW LIBRARY EXPLORER

Search result

Available models

Model Co 	Manufactu...	Description	Rated Flow...	Rated P
M-SR15KE0...	Bosch Rexr...	Check Valve	31.79	4600
OT.U5.01.00...	Bosch Rexr...	Check Valve	13	5000
CV3-10-P-0...	Eaton	Check Valve	20	5000
RV10A-01-...	Hydac	Check Valve	21	6000
CV08-20-0-...	HydraForce	Check Valve	8	3500
D02B2-0.0N	Parker	Check Valve	21	6000
CVH103P	Parker	Check Valve	16	5000
CP102-1-B-...	Sauer-Danf...	Check Valve	55	3000

Search Result – Filter

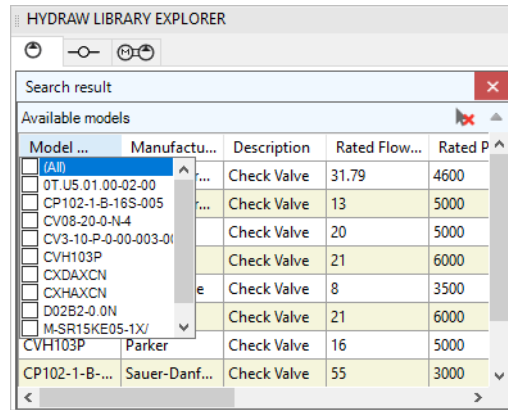

HYDRAW LIBRARY EXPLORER

Search result

Available models

Model ...	Manufactu...	Description	Rated Flow...	Rated P
<input type="checkbox"/> (All)				
<input type="checkbox"/> OT.U5.01.00-02-00	...	Check Valve	31.79	4600
<input type="checkbox"/> CP102-1-B-16S-005	...	Check Valve	13	5000
<input type="checkbox"/> CV08-20-0-N4		Check Valve	20	5000
<input type="checkbox"/> CV3-10-P-0-00-003-01		Check Valve	21	6000
<input type="checkbox"/> CVH103P		Check Valve	21	6000
<input type="checkbox"/> CXDAXCN		Check Valve	8	3500
<input type="checkbox"/> CXHAXCN	e	Check Valve	8	3500
<input type="checkbox"/> D02B2-0.0N		Check Valve	21	6000
<input type="checkbox"/> M-SR15KE05-1X/		Check Valve	16	5000
<input type="checkbox"/> CVH103P	Parker	Check Valve	16	5000
<input type="checkbox"/> CP102-1-B-...	Sauer-Danf...	Check Valve	55	3000

Search Result – Select property value

Clear Selection

Click  button to clear the model selection.

Symbols are displayed in the preview pane as per search criteria.

Models Context Menu

- Right click and select **Search for complete Model Code** from the context menu to display the model codes for the selected model family.

*The **Model Code** results display with model family.*

- Right click and select **View Model Properties** from the context menu to display the component data window.

*The **Component Model Properties** window displays details of the component.*

- Right click and select **View Data Sheet** from the context menu to view the data sheet attached to the model code.

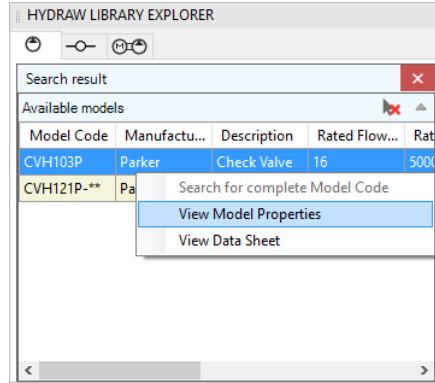

Models context menu

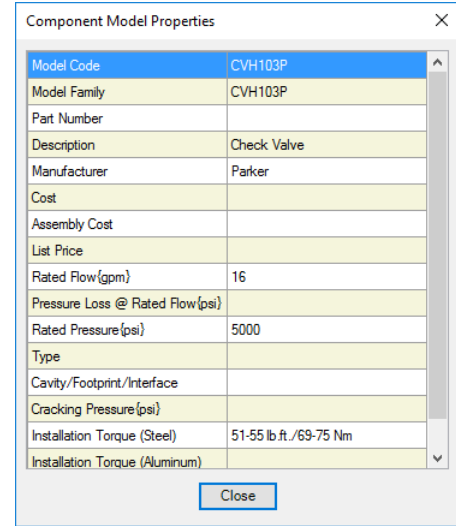

Component data

1. Click  Close button to return to the main search window and search with different inputs, if required.

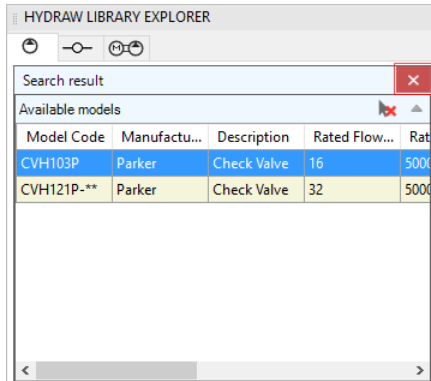

Close search results

2. Select the symbol in the preview pane; drag and drop
Alternatively, double click the symbol to insert the symbol into the drawing.
3. Replace the symbol in the drawing with another one from the library by selecting the **Replace symbol** checkbox in the HyDraw Library Explorer window, if required.
4. Drag and Drop the symbol in the drawing
Alternatively, double click the symbol to insert the symbol in the drawing.
The Specify insertion point prompts displays.
5. Specify the **Insertion Point** or Select **Rotate/Flip** option.
The symbol is inserted in the drawing.

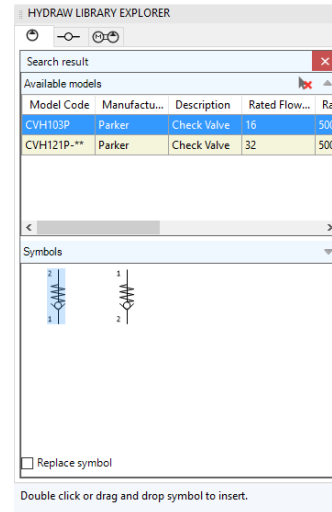

Symbol dragged and dropped into the drawing

Auto Naming and Grouping of Components

Assigns sequential Numbers to the Component Symbols and groups Identical Component Symbols when inserted in the Drawing.

Insert Symbol from Library

- By Default, symbols will be inserted following Sequential Numbering option in Item ID.
- Inserting symbols from Library assigns Numeric values with the increment of 1.

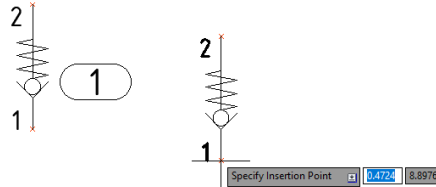

Symbol during Insertion

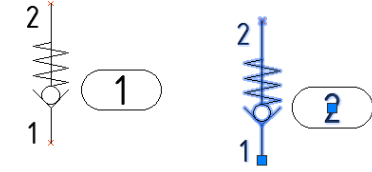

Inserted Symbol with Automatic ItemID

Insert Symbol from Component Search

- By Default, symbols will be inserted following Sequential Numbering option in Item ID.
- Inserting Component Symbols from Search has Model Properties filled and identified as a Component Directly.
- Inserting same symbol with Property values filled, groups the Symbols following the options set for Item ID in HyDraw options.

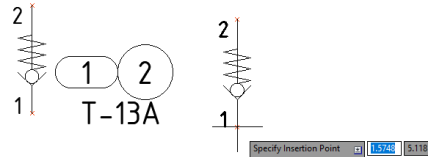

Symbol with Component Data during Insertion

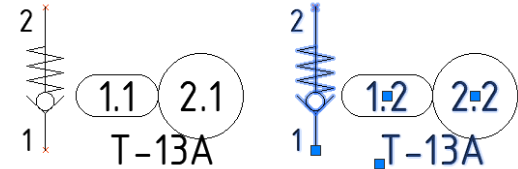

Inserted Component Symbol with Automatic Item ID - Grouped

Note:

For Automatic Grouping of Components, Grouping option must be selected in **HyDraw options>Item ID**. Refer Ch. 8 - HyDraw Options> Item ID

Insert Symbol from Parts List

- Parts List is assigned with Item ID for all Components when loaded.
- By default, symbols will be inserted based on the Sequential Numbering option selected in the Item ID tab.
- Inserting Symbols from Parts List has Model Properties filled and identified as a Component Directly.
- Inserting same symbol from Parts List groups the Symbols following the options set for Item ID in HyDraw options.

Note:

- Copying and Inserting HyDraw symbols in the drawing is based on the automatic naming and smart grouping of Item IDs set in HyDraw Options.
- Mirroring a schematic or a portion in the drawing is based on the automatic naming and smart grouping of Item IDs set in HyDraw Options.
- For ISO Numbering scheme, the first item ID is manually provided by double clicking the Item ID or the HyDraw Property Manager.
The program stores the prefix and generates automatic Item ID based on the last used ID.

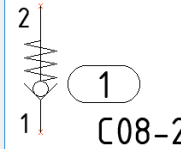
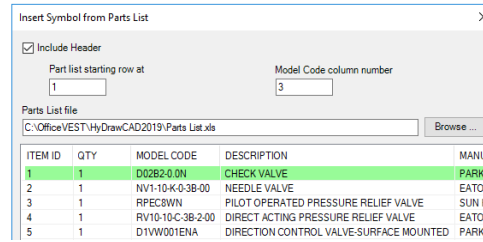

Symbol Inserted from Parts List – Automatic Item ID

10. Insert External Port

Insert ports on the envelope line in a circuit drawing.
Configure and edit the ports to suit the circuit requirements.

1. Click  tab on the HyDraw® Library Explorer window.
The External Port Library tab page displays.
2. Click on the Configure External Port caption bar to expand, if the section is not open.
3. Type the **Item ID** in the text box, for example, P, T, 1.
The default Item ID is ‘?’.

4. Select Pressure line port or Return line port.
5. Enter parameters for **Pressure** and **Flow**.
6. Select **Port Type** from SAE O-ring, SAE Flange, BSP, NPT, and Metric.

*On selection, different port sizes of the respective port type are displayed automatically.
Choose the required one.*

7. Select and drag the plugged or unplugged port from the preview section on the drawing.
Alternatively,
Double click the plugged or unplugged port.
Specify insertion point displays on the command window.

Once you specify the insertion point, the port is inserted into the drawing.

If the port symbol is placed over the envelope line, it attaches itself to the envelope line.

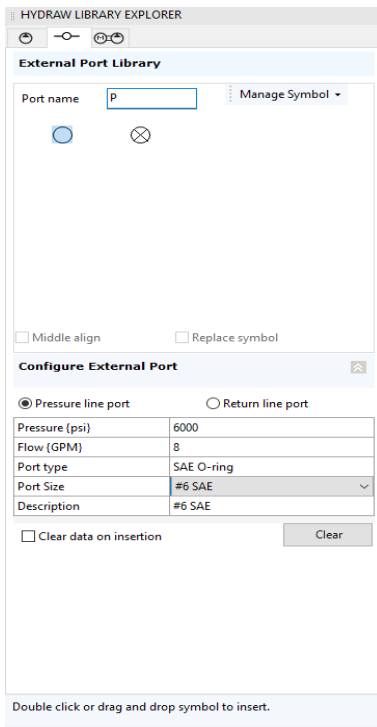

External Port Library tab page

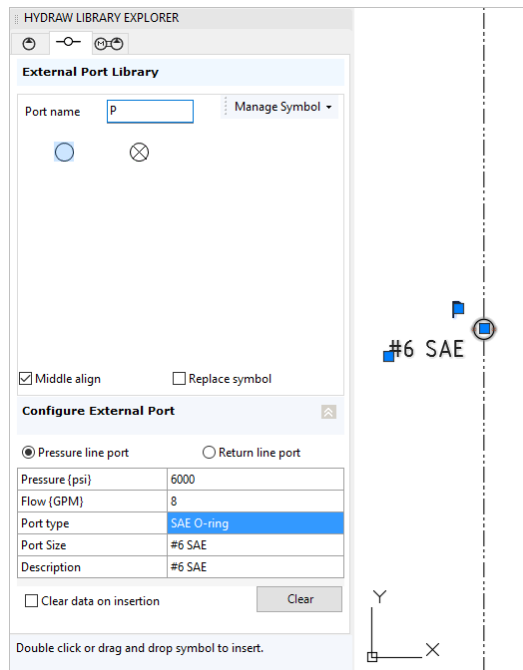

External Port inserted into the drawing

Port Data - Select from Library

1. Click **Circuit > Edit**  on the HyDraw® CAD ribbon menu.

The HyDraw Property Manager window displays.

2. Select the external port.

The HyDraw Property Manager displays the properties of the external port.

3. Click  on the Port data caption bar to select the port data from the library.

The Configure External Port dialog box displays.

4. Select the Pressure line port/Return line port.

5. Select **Port Type** from the drop down: SAE O-ring, SAE Flange, BSP, NPT, and Metric.

On selection, different port sizes of the respective port type are displayed automatically.

6. Select the required Port Size

7. Click **OK** to choose the selected port data from the library.

Note:

The port data can embed **With O-ring** and **With Through Bolt Hole** from HyDraw to MDTools®.

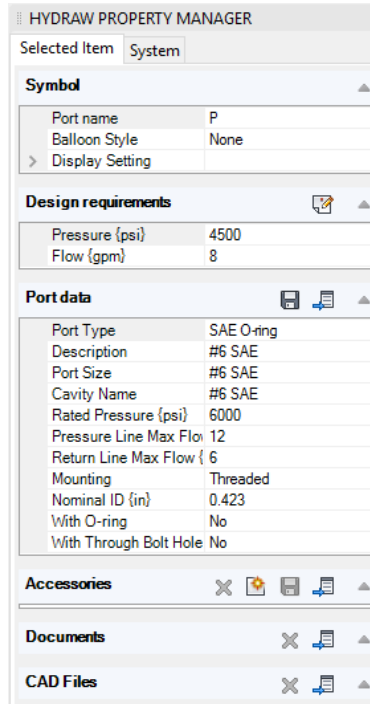

The screenshot shows the 'HYDRAW PROPERTY MANAGER' window with the 'System' tab selected. The 'Selected Item' is 'System'. The 'Symbol' section shows 'Port name' as 'P', 'Balloon Style' as 'None', and a 'Display Setting' dropdown. The 'Design requirements' section shows 'Pressure (psi)' as 4500 and 'Flow (gpm)' as 8. The 'Port data' section is expanded, showing a table of properties: Port Type (SAE O-ring), Description (#6 SAE), Port Size (#6 SAE), Cavity Name (#6 SAE), Rated Pressure (psi) (6000), Pressure Line Max Flow (12), Return Line Max Flow (6), Mounting (Threaded), Nominal ID (in) (0.423), With O-ring (No), and With Through Bolt Hole (No). Below this are sections for 'Accessories', 'Documents', and 'CAD Files', each with a close button, an add icon, and a refresh icon.

Symbol	
Port name	P
Balloon Style	None
Display Setting	

Design requirements	
Pressure (psi)	4500
Flow (gpm)	8

Port data	
Port Type	SAE O-ring
Description	#6 SAE
Port Size	#6 SAE
Cavity Name	#6 SAE
Rated Pressure (psi)	6000
Pressure Line Max Flow	12
Return Line Max Flow	6
Mounting	Threaded
Nominal ID (in)	0.423
With O-ring	No
With Through Bolt Hole	No

Accessories	

Documents	

CAD Files	

HyDraw Property Manager – Port

Configure External Port

Configure different external ports shape.

1. Click  on the HyDraw® CAD ribbon menu.
2. Click the **External Port** tab.

The External Port tab page displays.

3. Select the appropriate port shape, such as circle, oval, line, rectangle, or square.

The respective shape displays in the Port Preview section of the HyDraw Library Explorer window.

The external port can be placed on the envelope line of the circuit.

4. Click **OK** to apply and exit.

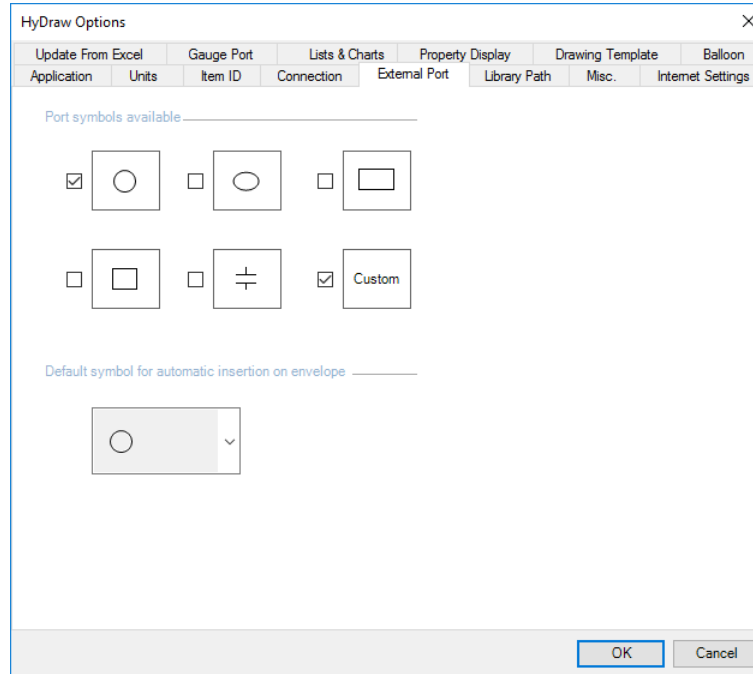

External Port tab

Replace External Port

Replace the port in the drawing with another port from the library.

1. Select the symbol to replace in the drawing.
2. Select the **Replace symbol** checkbox in the HyDraw® Library Explorer window, if required.
3. Drag and drop the new port on the drawing.
Alternatively,
Double click the plugged or unplugged port.

The Specify insertion point displays on the command window.

Once you specify the insertion point, the port is replaced on the drawing.

If the port symbol is placed over the envelope line, it attaches itself to the envelope line.

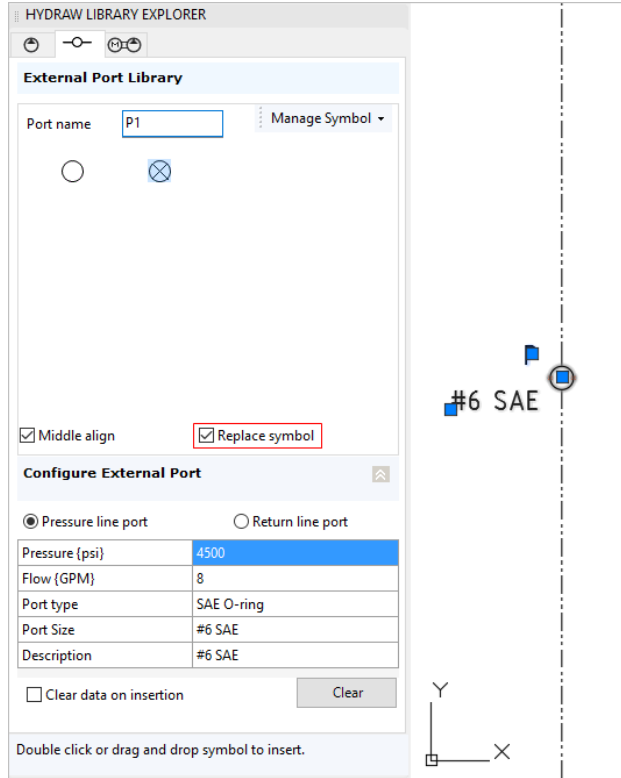

Replace symbol, Unplugged with Plugged External Port

11. Insert Sub-Systems

Search and Insert Sub-Systems from Library into the drawing.

1. Insert Sub-System from Library

1. Select the appropriate library and navigate to the required sub-system.
2. Drag the sub-system from the HyDraw Library Explorer window into the drawing.

Alternatively,
Double click the sub-system on HyDraw Library Explorer window.

Sub-System preview appears on the drawing space.

The Specify insertion point prompt displays.

3. Specify the **Insertion Point** or Select **Rotate/Flip** option. Select Rotate **Left/Right** and/or select Flip, **Vertical /Horizontal**.

The sub-system is placed on the drawing.

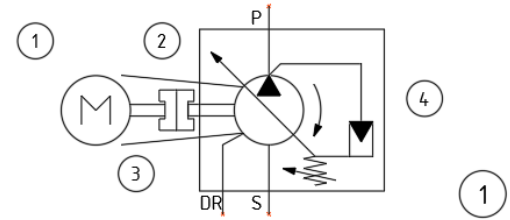
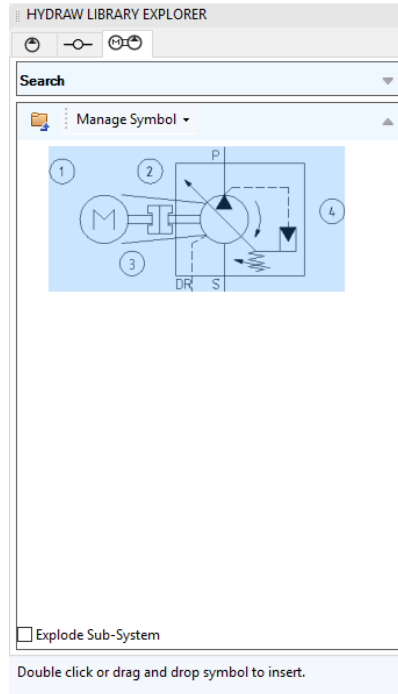

Double click or Drag and drop sub-system from Library into the drawing

Explode Sub-System

1. Select the Sub-System to explode in the drawing.
2. Select the Explode **Sub-System** check box in the HyDraw Library Explorer.
3. Drag and drop the new sub-system on the drawing.

Alternatively,
Double click the new sub-system on HyDraw Explorer window.

Sub-System preview appears on the drawing space.

The Specify insertion point prompts displays

4. Specify the Insertion Point.
The Sub-System is exploded on the drawing.

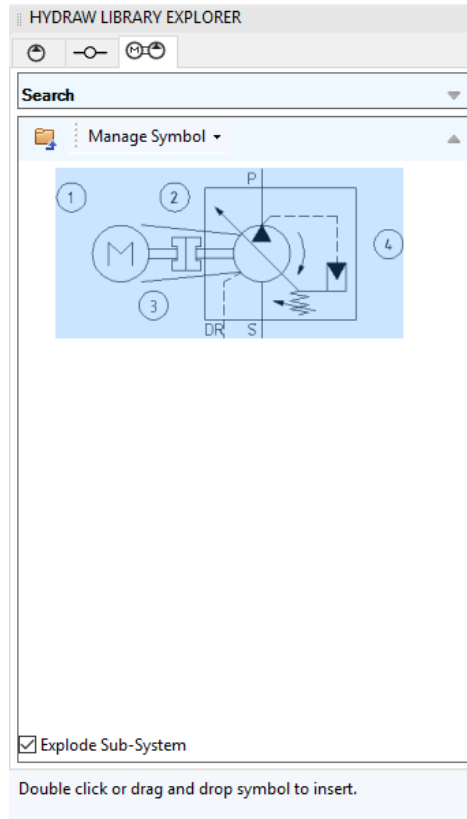

Explode Sub-System from Library into the drawing

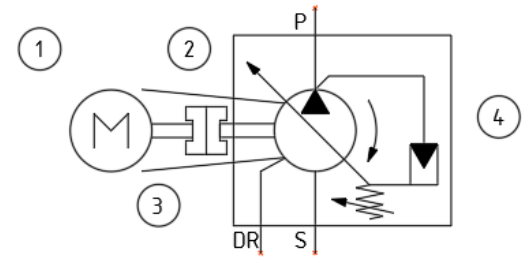

2. Search and Insert Sub-Systems

1. Click  button in the Search section.

The Search section page displays.

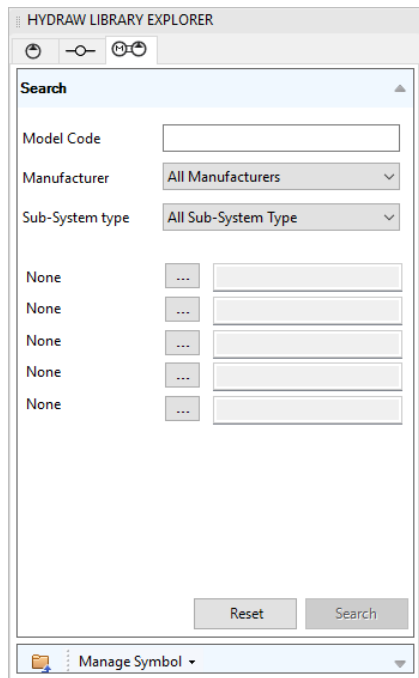

The screenshot shows the 'HYDRAW LIBRARY EXPLORER' window with the 'Search' tab selected. The search section includes a 'Model Code' text input field, a 'Manufacturer' dropdown menu set to 'All Manufacturers', and a 'Sub-System type' dropdown menu set to 'All Sub-System Type'. Below these are five rows, each with a 'None' label, a three-dot menu icon, and an empty text input field. At the bottom of the search section are 'Reset' and 'Search' buttons. A 'Manage Symbol' dropdown menu is visible at the very bottom of the window.

Default Search tab page

2. Enter the **Model Code** to search a particular sub-system type.

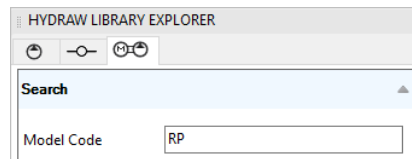

This screenshot is similar to the previous one, but the 'Model Code' text input field now contains the text 'RP'.

Enter Model Code

3. Select the manufacturer from the drop-down list.

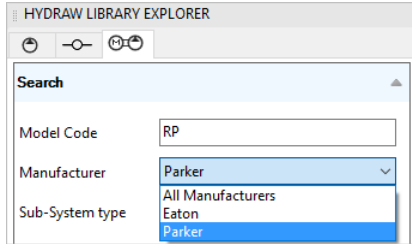

Manufacturer options

4. Select the appropriate Sub-System type from the drop-down list.

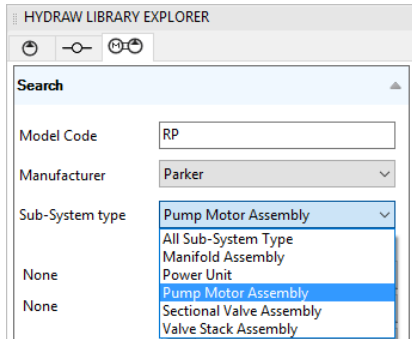

Sub-System type options

5. Define more criteria



Define More Criteria options

- For precise search, define custom search parameters by model properties.
- Click to view the Select Property box, which displays common properties.
- Select the property you want to assign.
- Enter the property value, for example 10, or range, for example 10-20.

Property range must be separated by a hyphen (-).

6. Select Property.

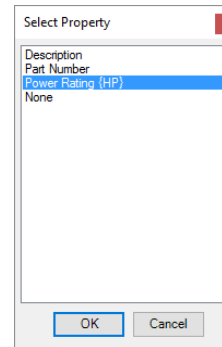

Select Property dialog

7. Click the **Search** button.

All model codes with the assigned custom properties are displayed in the Search result pane.

HYDRAW LIBRARY EXPLORER

Search

Model Code: RP

Manufacturer: All Manufacturers

Sub-System type: Pump Motor Assembly

Rated Flow(gpm): 55

Rated Pressure(psi): 5000

None

None

None

Reset Search

Search Model code with precise criteria

8. Select the appropriate model code in the preview pane.

The Search results are displayed in the pane.

HYDRAW LIBRARY EXPLORER

Search result

Available models

Model Code	Manufactu...	Description	Part Num...
RP2700	Custom	Pump Mot...	M100020

Sub-Systems

Explode Sub-System

Double click or drag and drop symbol to insert.

Preview sub-systems

Filter Search Results

On mouse hover the property header, click  button to select the required property value.

The Available models display as per selected property value.

By default, all properties value displays in the available models.

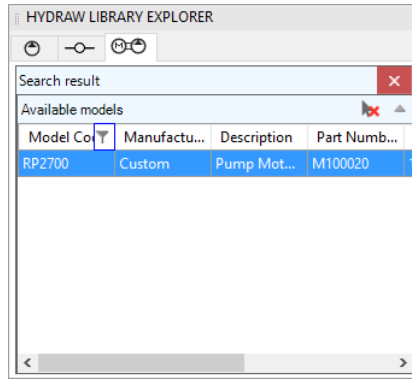

Search Results – Filter

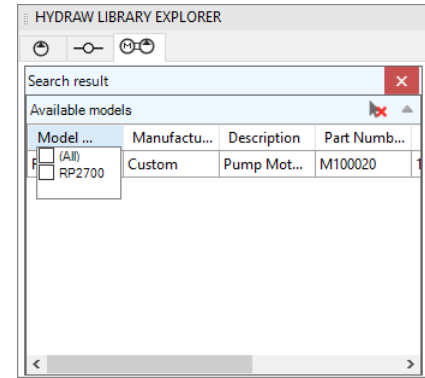

Search Results – Select property value

Clear Selection

Click  button to clear the model selection.

Sub-Systems are displayed in the preview pane as per search criteria.

Models Context Menu

Right click and select **View Model Properties** from the context menu to display the sub-system data window.

*The **Sub-System Model Properties** window displays details about the sub-system.*

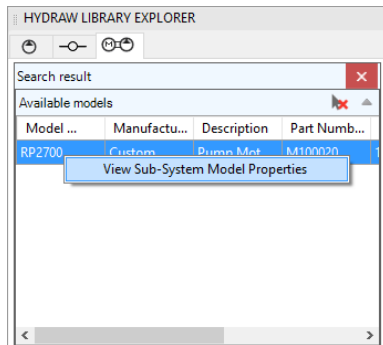

Model context menu

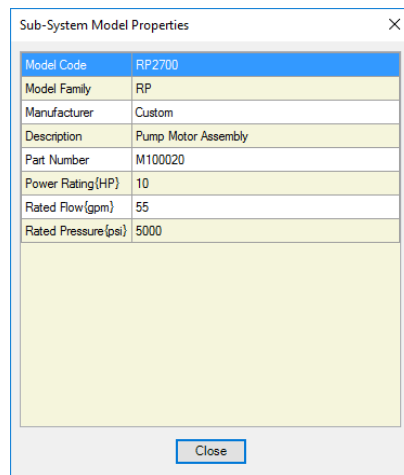

Sub-System data

9. Click  Close button to return to the main search window and search with different inputs, if required.

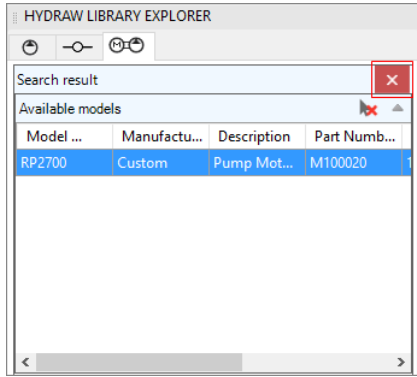

Close search results

10. Select the sub-system in the preview pane; drag and drop. Alternatively, double click the sub-system to insert the sub-system in the drawing.
- Explode the symbol in the drawing from the library by selecting the **Explode Sub-System** checkbox in the HyDraw Library Explorer window, if required.
 - Drag and drop the sub-system on the drawing
Alternatively, double click the sub-system to insert the sub-system in the drawing.
The Specify insertion point prompts display.

11. Specify the **Insertion Point** or Select **Rotate/Flip** option.

The sub-system is inserted in the drawing.

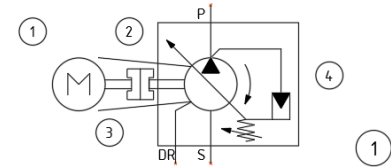
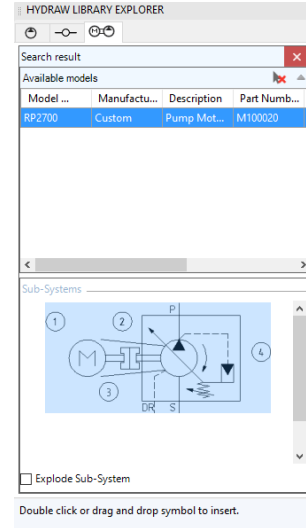

Sub-System dragged and dropped in the drawing

12. Insert from Parts List

Insert symbols from Parts List in Excel.

Note: Each item in the Parts list is identified by its unique model code. Therefore, the Parts list must contain a model code for each item in the list.

1. Select Circuit > **From Parts List** > Insert Symbol on the HyDraw[®] CAD ribbon menu.

The Insert Symbol from Parts List dialog box displays.

2. Enter the Part list starting row at option and the Model Code column number.
3. Click **Browse...**

The Select Parts List Excel file dialog box displays.

4. Select the required Excel file containing the Parts list and click **Open**.

Contents of the Excel file are displayed.

5. Type **Model Code** column number in the textbox, if it is not automatically entered.
6. Select the Models and click **Insert** or **Insert All** to insert all the symbols in the drawing.

Linked Symbols dialog box displays when multiple symbols are linked to the selected model.

For Insert symbol detailed information, refer chapter no 9.

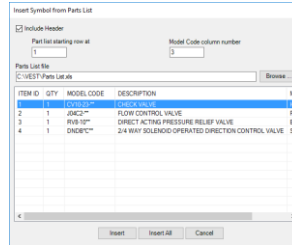

Insert Symbols from Parts List dialog box

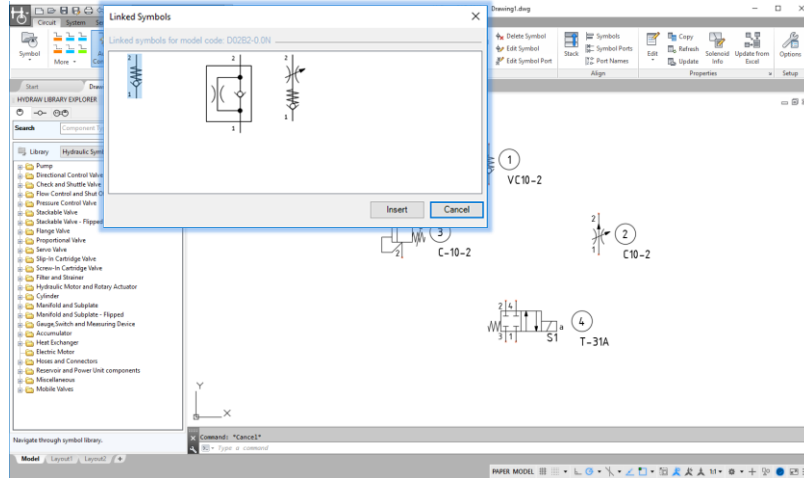

Insert Linked Symbol from Parts List

13.Insert Terminators

Insert terminators dynamically for any unused component ports and connection lines.

1. Click Circuit > **Terminator**  on the HyDraw® CAD ribbon menu.

The Select symbol port prompt displays.

2. Select the symbol port for the terminator insertion.

The terminator is inserted at the location.

Terminators are inserted automatically for all unused ports of all selected symbols and sub-systems.

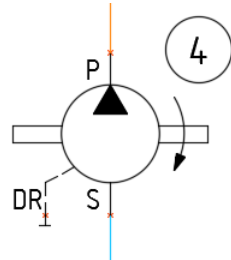

Dynamic terminators

Note:

- The terminator indicates the unused component port.
- Terminator is essential in the Net List creation. A net remains incomplete, if a port is left unconnected.
- The Net list can indicate unconnected circuit lines and ports.
- When you rotate the symbol and sub-systems, the terminator also rotates along with it.

14. Insert Symbol Port

Insert connection points on the ports of a symbol.

1. Click Circuit > **Insert Symbol port**  on the HyDraw® CAD ribbon menu.
The Select Symbol to Insert Port prompt displays.
2. Select the symbol.
The Port Name: prompt displays.
3. Enter the Port Name in the command window and press the **Enter** key.
The Other Name: prompt displays.
4. Enter the other name in the command window, if required and press the **Enter** key.
The Specify Port Insertion Point: prompt displays.
5. Specify the Port Insertion point on the symbol.
A small red cross appears at the point where the port is inserted.

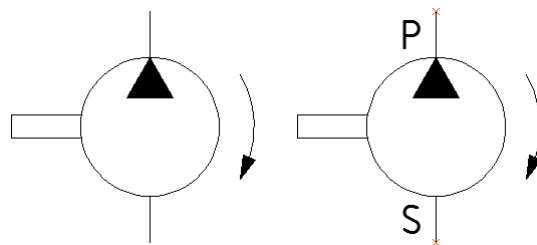

Inserting a Symbol Port

15. Insert Envelope

Insert an envelope to define a boundary for a manifold or a system.

1. Click Circuit >  **Envelope** on the HyDraw® CAD ribbon menu.
The Specify first corner point prompt displays.
2. Select the first corner point on the drawing.
The Specify other corner point prompt displays.
3. Select the other corner point on the drawing.
The envelope is inserted.

The smart envelope has following functionalities:

- a. Insert ports automatically on the envelope line intersection with connection lines.

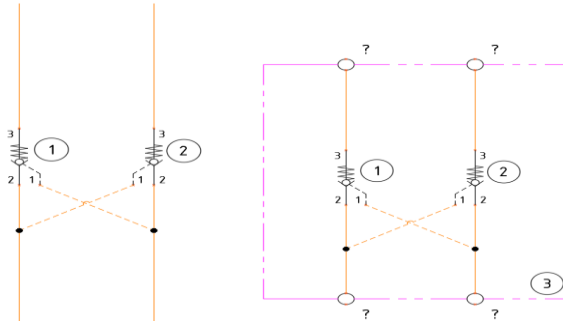

Ports automatically inserted on envelope line intersection

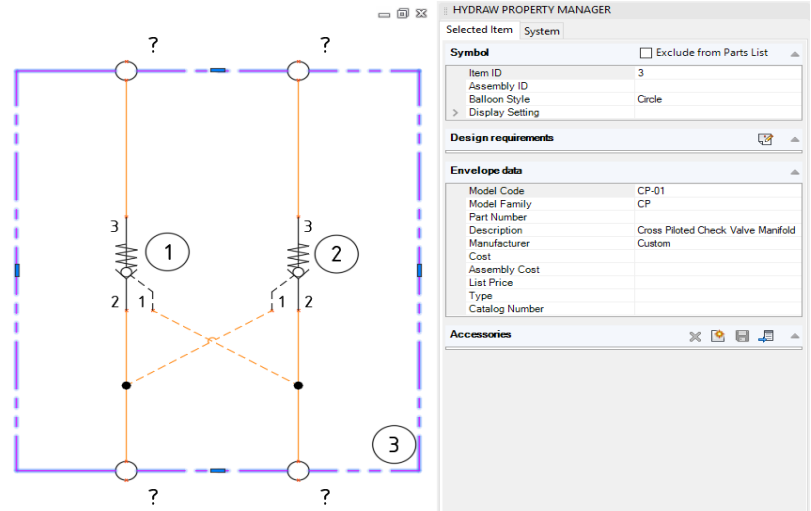

Envelope data of the selected Envelope Line

- b. Hanging connection lines automatically deleted when automatic insertion of ports on the envelope line.
- c. Envelope line is made of polyline and can be easily resized by the resize handle.
- d. External ports are glued to the envelope and relocates the ports and maintain connectivity while resizing the envelope.
- e. Envelope data is attached to the envelope line.

16. Insert Gauge Port

Insert a gauge port to define a boundary for a manifold or a system.

1. Click Circuit >  Gauge on the HyDraw® CAD ribbon menu.
The Select ports to insert gauge port prompt displays.
The Port type (Open/Close) prompt displays.
The default symbol also displays.
The insertion location [Above/Below/Left/Right] prompt displays.
HyDraw inserts the gauge ports for all the selected external ports and automatically inserts Item ID and connects using the connection line.
2. Select the external port(s) on the drawing.
The Port type (Open/Close) prompt displays.
The default symbol also displays.
The insertion location [Above/Below/Left/Right] prompt displays.
HyDraw inserts the gauge ports for all the selected external ports and automatically inserts Item ID and connects using the connection line.
3. To configure the gauge port, select the Gauge tab option.

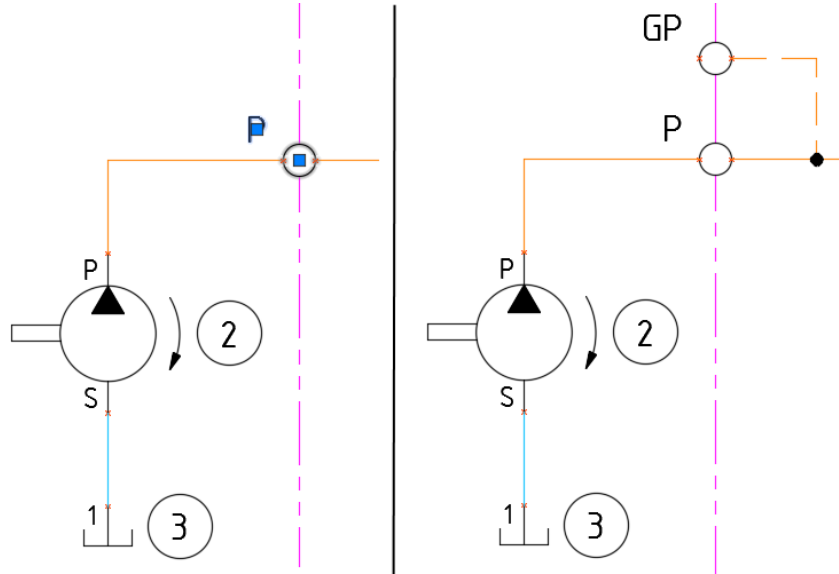

Gauge port GP is inserted in parallel to the existing selected external port

17.Insert Orifice Disc

Insert an orifice disc for Port #1 of cartridge symbols and external ports.

1. Click Circuit >  **Orifice Disc** on the HyDraw® CAD ribbon menu.

The Select a Symbol prompt displays.

2. Select the symbol.

Insert Orifice Disc dialog box displays.

3. Select the orifice disc symbol which you want insert.

4. Select the model data linked to the symbol.

5. Click OK.

A warning message box displays, if you select unconnected symbol Port #1 or Port #1 is not available in the cartridge symbol.

Symbol preview appears on the drawing space.

6. Click on the drawing space or Select any of the **Flip, Vertical /Horizontal** options.

The Orifice Disc is automatically inserted on the Port #1 of the selected cartridge symbol or external port on the drawing.

Note:

- Individual symbols of Cartridge symbol and Orifice disc are combined with “&” and accepted as a single entity in the **HyDraw Export to MDTools**.
- Orifice Disc item ID should not be listed, when creating **Net List**.

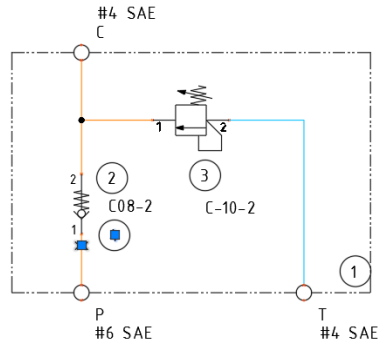

Orifice Disc automatically inserted on Port #1 of the cartridge symbol

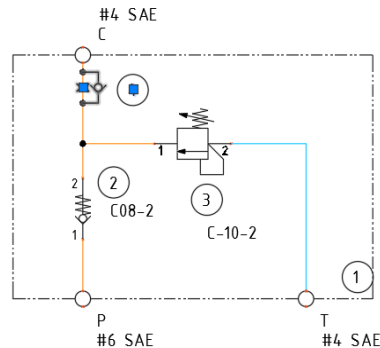

Orifice Disc automatically inserted on the INT port of the external port

18. Insert Jumping Reference

Insert jumping reference to the unconnected end of a connection line.

1. Click Circuit >  **Jumping Reference** on the HyDraw® CAD ribbon menu.

The Select connection line prompt displays.

2. Select the unconnected end of a connection line.

A warning message box displays, if you select a non-free end connection line.

The Insert Jumping Reference dialog box displays.

3. Enter the **Name** of jumping reference.
4. Select the **Circuit type** from drop-down list, If the Use circuit type option is selected in the HyDraw Options > Connection > Jumping Reference.
5. Enter the Destination sheet.
6. Enter the **Grid square**, If the Use grid square option is selected in the HyDraw Options > Connection > Jumping Reference.
7. Click OK.

The jumping reference is automatically inserted vertically or horizontally on the unconnected end of a connection line.

On the basis of connection line segment, jumping reference is automatically inserted vertically or horizontally on the connection line.

Note:

You cannot create jumping reference with the same name for more than one pair of unconnected connection line.

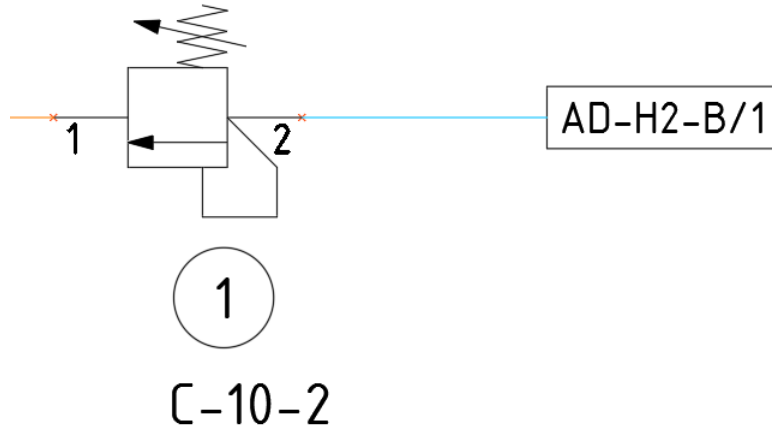

Jumping Reference automatically inserted on unconnected end of the connection line

Make Connections

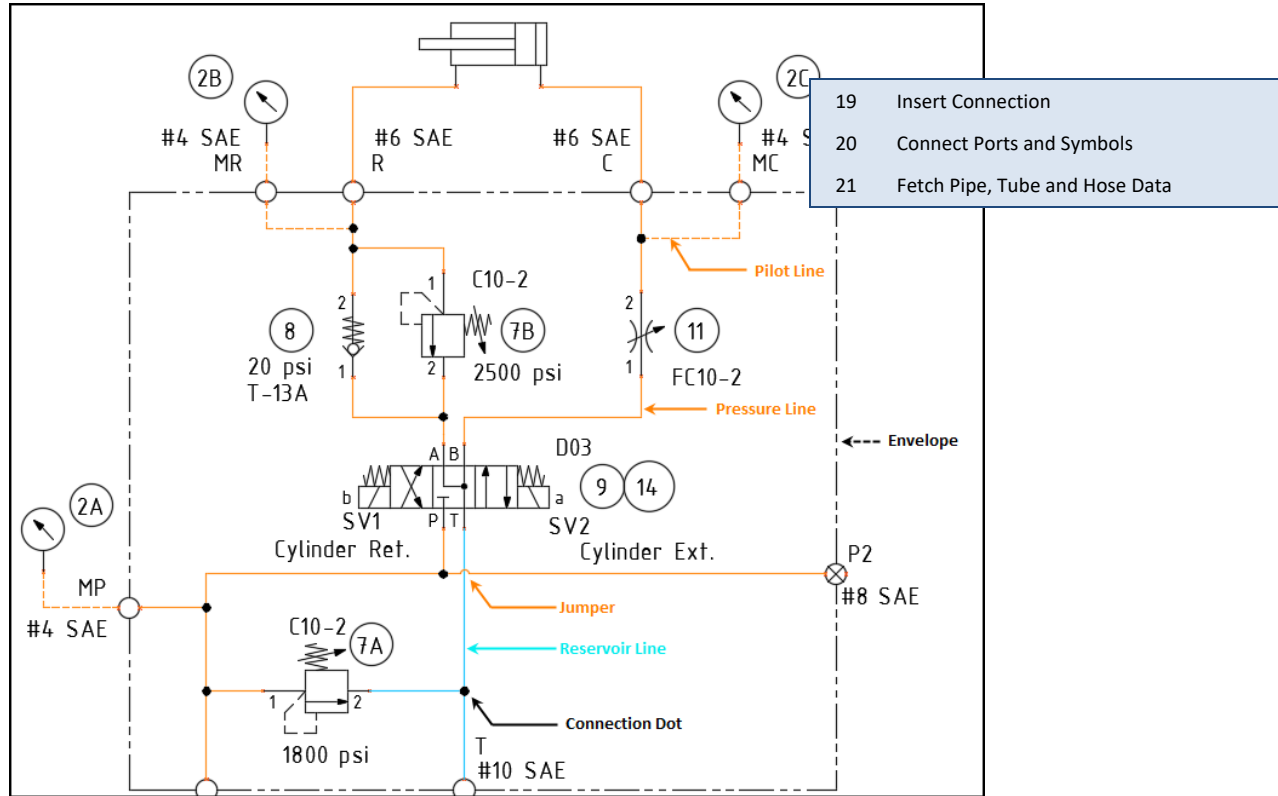

19. Insert Connection

Interconnect symbols and create a circuit.

Auto Connect: The Auto Connect property, when enabled before making a connection, automatically creates the connection between the two selected points.

When the Auto Connect property is disabled, the connection has to be created manually between the selected points.

When Ortho is ON, the termination point can be selected only in the four mutually perpendicular directions of the starting point.

When Ortho is OFF, the termination point can be anywhere around the start point.

1. Enable/Disable **Auto Connect** on the HyDraw® CAD ribbon menu.
2. Click on the Connection type from Pressure, Reservoir, Control, Drain, Suction, Working or Custom from Line1, Line2, Line3, Line4, and Line5 options on the HyDraw CAD ribbon menu.

Connection lines are assigned with the default ISO color and line weight.

You can customize the connection lines.

The Select first connection point prompt displays.

3. Select the first connection point on the drawing as the start point.

When the Auto Connect option is enabled:

The Select second connection point prompt displays.

4. Select the second connection point as the termination point.

When the Auto Connect option is disabled:

The Select Next point prompt displays.

5. Select the next connection point.
6. Press the **Enter** key when the connection is complete.

The connection line is drawn between the two points.

7. Customize the connection lines, if required.

Note:

- If a connection is drawn at the end/start of another same type connection line with a tolerance of 0.1" or 2.54 mm, the connection lines automatically merges to a single polyline.
- If a connection line is drawn without connecting symbol ports or connection lines, the jumping reference is automatically placed on the unconnected end of the connection line, if the **Use auto insert** option is selected on the HyDraw Option > Connections > Jumping Reference.

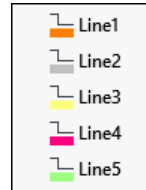
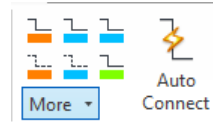

Insert Connection sub menus

21.Fetch Pipe, Tube and Hose Data

Connection lines can be assigned to the Tube, Pipe and Hose data from the library, based on the design requirements. Specify Connector type for the connection line to select the default connection properties from the library.

1. Select the connection line.
2. Select the connector type from the drop-down list.
3. Specify the **design requirements, pressure** and **flow** for the selected connection lines in the HyDraw® Property Manager.
4. Click the Select from Library icon.

The Fetch Pipe/Tube/Hose from Library dialog box displays.

5. Select either Pressure line or Return line.
6. Select **Type**, i.e. Pipe/Tube/Hose.
7. Select **Material**.

Pressure and flow are automatically displayed in the Design requirements section. Velocity is displayed per the recommended velocity set in the HyDraw Options dialog box.

The inner diameter is based on the flow and velocity, and the appropriate pipe/tube/hose is selected by default in the grid displaying all the other available pipes/tubes/hoses with velocity.

8. Select the required pipe, tube or hose.
9. Click **OK** and exit.

Note:

For Drill Hole and Electrical type connector, the **Select from Library** option is not applicable.

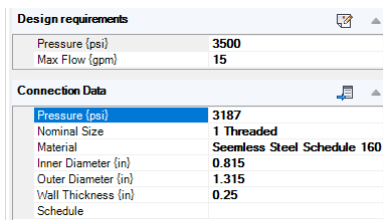

The dialog box is divided into two sections: Design requirements and Connection Data. Design requirements shows Pressure (psi) at 3500 and Max Flow (gpm) at 15. Connection Data shows Pressure (psi) at 3187, Nominal Size at 1 Threaded, Material at Seamless Steel Schedule 160, Inner Diameter (in) at 0.815, Outer Diameter (in) at 1.315, Wall Thickness (in) at 0.25, and Schedule at 160.

HyDraw Property Manager – Connection Data

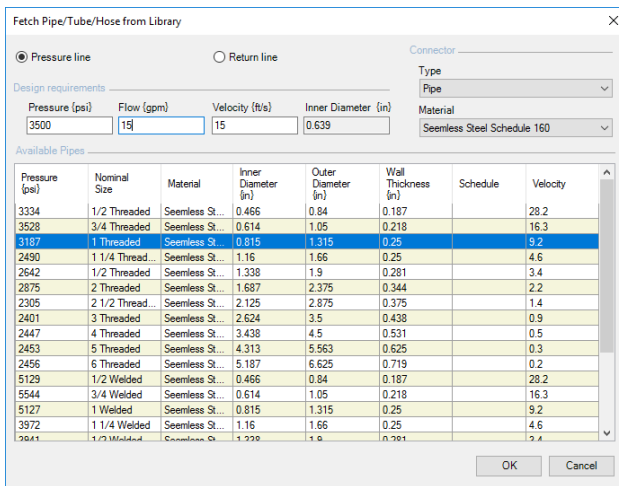

The dialog box has radio buttons for Pressure line (selected) and Return line. The Connector dropdown is set to Pipe. Design requirements show Pressure (psi) at 3500, Flow (gpm) at 15, Velocity (ft/s) at 15, and Inner Diameter (in) at 0.639. The Material dropdown is set to Seamless Steel Schedule 160. Below is a table of available pipes.

Pressure (psi)	Nominal Size	Material	Inner Diameter (in)	Outer Diameter (in)	Wall Thickness (in)	Schedule	Velocity
3334	1/2 Threaded	Seamless St...	0.466	0.84	0.187		28.2
3528	3/4 Threaded	Seamless St...	0.614	1.05	0.218		16.3
3187	1 Threaded	Seamless St...	0.815	1.315	0.25		9.2
2490	1 1/4 Threaded	Seamless St...	1.16	1.66	0.25		4.6
2642	1/2 Threaded	Seamless St...	1.338	1.9	0.281		3.4
2875	2 Threaded	Seamless St...	1.687	2.375	0.344		2.2
2305	2 1/2 Threaded	Seamless St...	2.125	2.875	0.375		1.4
2401	3 Threaded	Seamless St...	2.624	3.5	0.438		0.9
2447	4 Threaded	Seamless St...	3.438	4.5	0.531		0.5
2453	5 Threaded	Seamless St...	4.313	5.563	0.625		0.3
2456	6 Threaded	Seamless St...	5.187	6.625	0.719		0.2
5129	1/2 Welded	Seamless St...	0.466	0.84	0.187		28.2
5544	3/4 Welded	Seamless St...	0.614	1.05	0.218		16.3
5127	1 Welded	Seamless St...	0.815	1.315	0.25		9.2
3972	1 1/4 Welded	Seamless St...	1.16	1.66	0.25		4.6
3941	1 1/2 Welded	Seamless St...	1.338	1.9	0.281		3.4

Fetch Pipe/Tube/Hose from Library

Modify Connection

HyDraw CAD 2019 Sample Circuit.dwg

Start Sample Circuit* x

22 Stretch Connections
23 Match Connections
24 Merge Connection
25 Reset Connections

ITEM ID	QTY	MODEL CODE	DESCRIPTION	MANUFACTURER
1	3	DYNL-FP250SAE	PRESSURE GAGE, 0-5000 PSI	DYN
2	1	302700	PUMP MOTOR ASSEMBLY	GLD
3	1	FZ1-20	HOSE	YUH
4	1	PR3-00	SUCTION STRAINER	EAT
5	2	ABLABP2-A	GREY ACTING PRESSURE RELIEF VALVE	SAE
6	1	CYDAXAN	CHECK VALVE	EAT
7	1	LW6EABX/Ew23ENK4	DIRECTION CONTROL VALVE	HYD
8	1	50A5K50BEPGG20	FILTER	EAT
9	1	SD10-01-0H	NEEDLE VALVE	HYD
10	1	LS47	PLUG & TEMPERATURE SWITCH	YUH
11	1	BR20	FILLER/BREATHER	YUH
12	1	RW041022	BLACK MATING CONNECTOR	BOG

ITEM ID	PORT TYPE	DESCRIPTION	PORT SIZE
BR, C, LVL, R	SAE O-RING	#6 SAE	#6 SAE
MC, MP, MR	SAE O-RING	#4 SAE	#4 SAE
PL, P2, PRL, T	SAE O-RING	#1 SAE	#1 SAE
TR1	SAE O-RING	#10 SAE	#10 SAE

NET NAME	NET LIST	NET PRESSURE (PSI)
NET-1	MC, L, C	3000
NET-2	T, T, SA-2	1500
NET-3	T, P, P1, MP, SA-1	3000
NET-4	MR, L, R, SB-1	3000
NET-6	MC, L, B	3500
NET-7	MC-1, SB-2, T, A	4000

FUNCTION	T-SV1	T-SV2	HOSE ID	QUANTITY	DESCRIPTION
CYLINDER EXT.	<input type="radio"/>	<input type="radio"/>	3	1	HOSE
CYLINDER RET.	<input type="radio"/>	<input type="radio"/>			

INSERT 1ST DR 3RD ANGLE PROJECTION SYMBOL HERE	DATE	BY	CHKD	COMPANY
				VEST, INC.

DESCRIPTION	REV	ISSUED	DATE
CYLINDER CONTROL	1		

30 NET SCALE DRAWING

PAPER MODEL

22.Stretch Connections

Stretch an existing connection line.

1. Click Circuit > **Stretch Connection**  on the HyDraw® CAD ribbon menu.

The Select a connection prompt displays.

2. Select a connection line.

The Specify point prompt displays.

3. Click a point on the drawing to specify the new location of the connection line.

The connection line gets stretched.

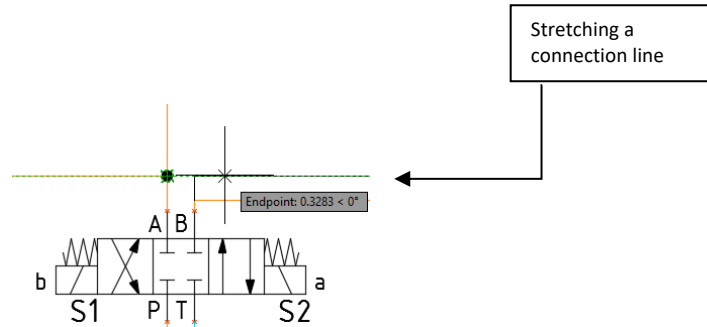

Stretching the connection

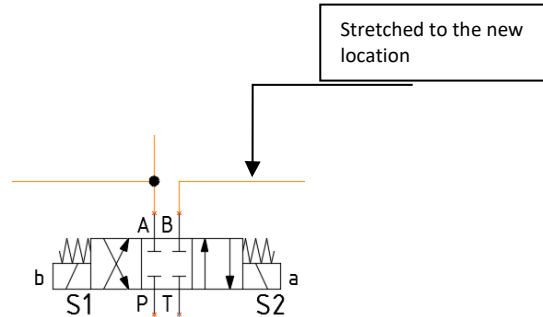

Circuit after Stretching the connection

23.Match Connections

Match the connection properties of one connection line with another.

1. Click Circuit > **Match Connection**  on the HyDraw® CAD ribbon menu.
The Select Source Connection prompt displays.
2. Select the source connection line.
The Select Destination connection(s) prompt displays.
3. Select a single line or multiple connection lines.
4. After completion of selection, press the **Enter** key.

The connection properties are copied.

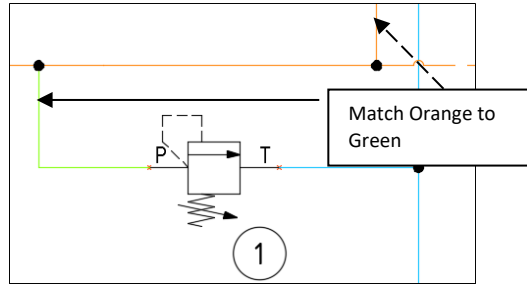

Circuit Before Matching Suction Connection line with Pressure Connection Line

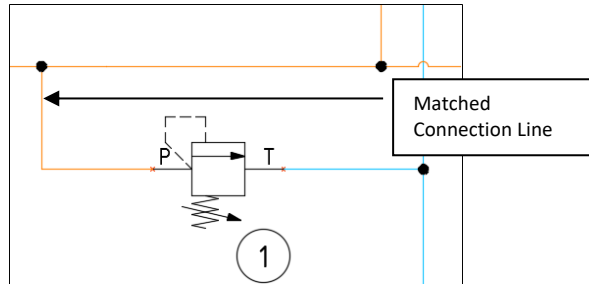

Circuit After Matching Connection

24. Merge Connection

Connect the same type HyDraw connection lines that are disconnected within specified tolerance.

1. Click **Circuit > Merge Connection**  on the HyDraw® CAD ribbon menu.

The select connections prompt displays.

2. Select two or more connection lines.
3. After completion of selection, press the **Enter** key.

A warning message box displays.

4. Click **OK** to continue or click **Cancel** to exit.

The same type connection lines are merged to a single polyline, if the distance between two adjacent end/start points of two connection lines are within tolerance of 0.1" or 2.54mm.

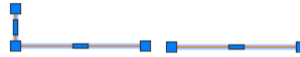

Before Merge



After Merge

25.Reset Connections

Convert a bend (slanting) connection line in to a right angled connection line.

1. On the command window (line), type the **Resetcon** command.

The Select a connection prompt displays.

2. Select the connection line that you want to reset.

The connection line resets to the right-angled connection line.

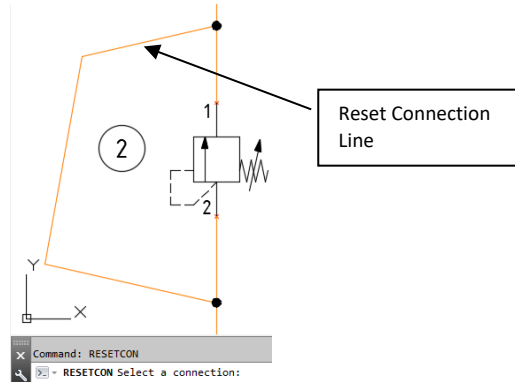

Connection Lines (Before Reset)

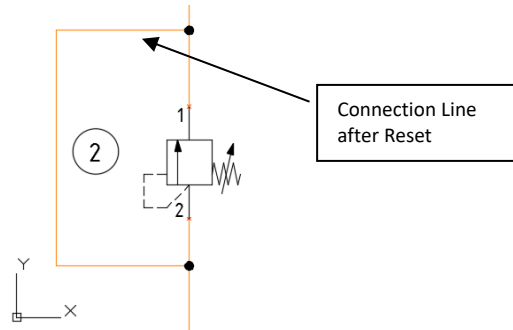

Connection Line (After Reset)

Specify Properties

The screenshot displays the HyDraw CAD 2019 interface with a hydraulic circuit diagram. A central menu overlay lists the following options:

- 26 Selected Item Properties
- 27 System Properties
- 28 Edit Properties
- 29 Copy Properties
- 30 Refresh Properties
- 31 Update Property List
- 32 Purge Properties
- 33 Purge Price Data
- 34 Edit Solenoid Information
- 35 Update from Excel

The background shows a detailed hydraulic schematic with various components like valves, pumps, and hoses. To the right, the 'HYDRAW PROPERTY MANAGER' is open, showing details for a selected 'System' item, including design requirements and model data.

ITEM ID	QTY
1	3
2	1
3	1
4	1
5	2
6	1
7	1
8	1
9	1
10	1
11	1
12	1

ITEM ID	PORT
BR. C. LVL. R	SAE
HC. HP. HR	SAE
P1. P2. PR1. T	SAE
TR1	SAE

NET NAME	NET LIST
NET-1	HC. 4-2.0
NET-2	P-1. T. 5
NET-3	P-2. P2.
NET-4	HC. 6-2.
NET-6	4-1. 7-B
NET-7	6-1. 5B-2.

FUNCTION	T-5V1	T-5V2
CYLINDER EXT.	<input type="radio"/>	<input type="radio"/>
CYLINDER RET.	<input type="radio"/>	<input type="radio"/>

HOSE ID	QUANTITY	DESCRIPTION
3	1	HOSE

NAME	DATE	COMPANY
DRYAN	04/20/2018	VEST, INC.
OPERED	04/20/2018	
PROJECTION	1/4"	
SYMBOL HERE		
DATE APPROVED	04/20/2018	
BY	DRYAN	
DATE CHECKED	04/20/2018	
BY	DRYAN	
DATE CHECKED	04/20/2018	
BY	DRYAN	
DATE CHECKED	04/20/2018	
BY	DRYAN	

ITEM	QUANTITY	SCALE	SHEET	OF
8	1		1	1

The 'HYDRAW PROPERTY MANAGER' on the right shows the following details for the selected 'System' item:

- Item ID: 7
- Assembly ID: Balloon Style
- Ballon Style: Circle
- Design requirements: Flow (gpm) 6, Pressure (psi) 3000
- Model data: Model Code 4WEG16X/EW230N9K4, Model Family 4WE6, Part Number 6112M8, Description Direction Control Valve, Manufacturer Hydac, Cost 27, Assembly Cost 5, List Price 236, Rated Flow (gpm) 21, Pressure Loss @ Rated Fl. 145, Rated Pressure (psi) 5000, Cavity/Footprint/Interface D03, Malfunction Flow (gpm) 21, Voltage 230, Frequency 50, Bolt Shoulder Height (in) 1.4, Installation Torque (Steel) 5.9 lb ft / 8 Nm, Installation Torque (Alumin) 5.9 lb ft / 8 Nm, Catalog Number RE Z3178/08 08

26. Selected Item Properties

Properties assigned to the selected symbol or sub-system in the drawing is displayed.
Add new accessories to the symbol or sub-system and save it to the library.

Select the symbol or sub-system in the drawing. The Selected Item tab page displays the following sections:

1. Symbol

The Symbol section displays the ID, balloon style, and various display settings of the symbol or sub-system.

- Customize the balloon style to circle, oval, rectangle, rounded rectangle, hexagon or none of these.
- Show or Hide various display settings with the symbol on the drawing.
- Click  to expand and then select Hide or Show to hide or show the respective parameters.
- Select the checkbox on the caption bar to include the Selected Item properties in the respective component Parts List of the circuit.

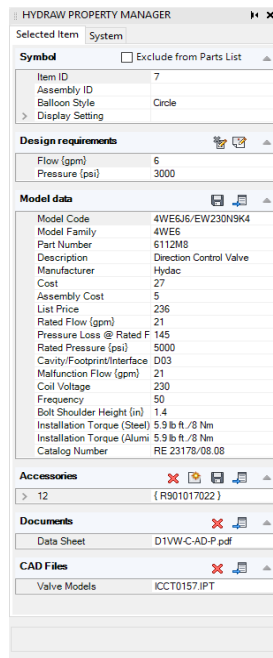



HYDRAW PROPERTY MANAGER	
Selected Item System	
Symbol <input type="checkbox"/> Exclude from Parts List	
Item ID	7
Assembly ID	
Balloon Style	Circle
Display Setting	
Design requirements	
Flow (gpm)	6
Pressure (psi)	3000
Model data	
Model Code	4WE6J6/EW230N9K4
Model Family	4WE6
Part Number	6112M6
Description	Direction Control Valve
Manufacturer	Hydac
Cost	27
Assembly Cost	5
List Price	236
Rated Flow (gpm)	21
Pressure Loss @ Rated F	145
Rated Pressure (psi)	5000
Cavity/Footprint/Interface	D03
Malfunction Flow (gpm)	21
Coil Voltage	230
Frequency	50
Bolt Shoulder Height (in)	1.4
Installation Torque (Steel)	5.9 lb ft./8 Nm
Installation Torque (Alumi)	5.9 lb ft./8 Nm
Catalog Number	RE 23178/08.08
Accessories	
	{ R901017022 }
Documents	
Data Sheet	D1VW-C-AD-F.pdf
CAD Files	
Valve Models	ICCT0157.IPT

Selected Item tab page

2. Design Requirements

The Design requirements section enables you to search for the required components by specifying a design parameter and value, from the library.

1. Type the value in the text box of the respective parameter.
2. Click  on the **Design Requirements** caption bar to open Edit Port Operating Parameters.
3. Specify separate flow and pressure for each port of a component.
4. Click  on **Edit Design Note** to add the design notes to the component.

The Design Note icon appears on the top of the Item ID.

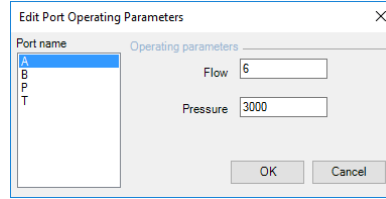

Edit Port Operating Parameters

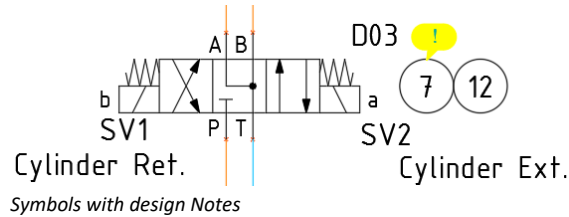

3. Model Data

Displays the details of the component selected.

Model data of the Component is the Model Properties.

1. Enter the values of Properties manually to fill in the Model Data.
or
2. Use  **Select from Library** to fetch the data from HyDraw Library.

Follow the steps in next section 4, to Select Data from Library.

Model data	
Model Code	4WE6J6X/EW230N9K4
Model Family	4WE6
Part Number	6112M8
Description	Direction Control Valve
Manufacturer	Hydac
Cost	27
Assembly Cost	5
List Price	236
Rated Flow {gpm}	21
Pressure Loss @ Rated Flow	145
Rated Pressure {psi}	5000
Cavity/Footprint/Interface	D03
Malfunction Flow {gpm}	21
Voltage	230
Frequency	50
Bolt Shoulder Height {in}	1.4
Installation Torque (Steel)	5.9 lb.ft./8 Nm
Installation Torque (Aluminum)	5.9 lb.ft./8 Nm
Catalog Number	RE 23178/08.08

Model data section

4. Select from Library

1. Select model data for a component using either the Local database installed on the system
OR
Online database of FluidPowerTools.com

Click  on the Model Data caption bar to fetch the component from the library.

The Select from Library dialog box displays with the input data.

2. Select the database to search, i.e.,
My local database or Fluidpowertools.com

If the My local database option is selected,
the program searches the component in the local database of the user.

If the FluidPowerTools.com database option is selected,
the split button on the right is enabled,

Data Access Settings

- In the Data Access Settings, select **manufacturer database** to search for components.

The Data Access Settings drop down provides other controls,
which includes:

Data Access Settings, Data library and Help topics, Usage terms and conditions, My Subscriptions information, and Contact.

- Click **Models linked to symbol** to display the component models linked to this symbol.
- Click **all models** to display all component models available to the component type of the symbol.
- Click the **Search** button to search for the component.

The search results display in the Search results pane.

Click **OK**.

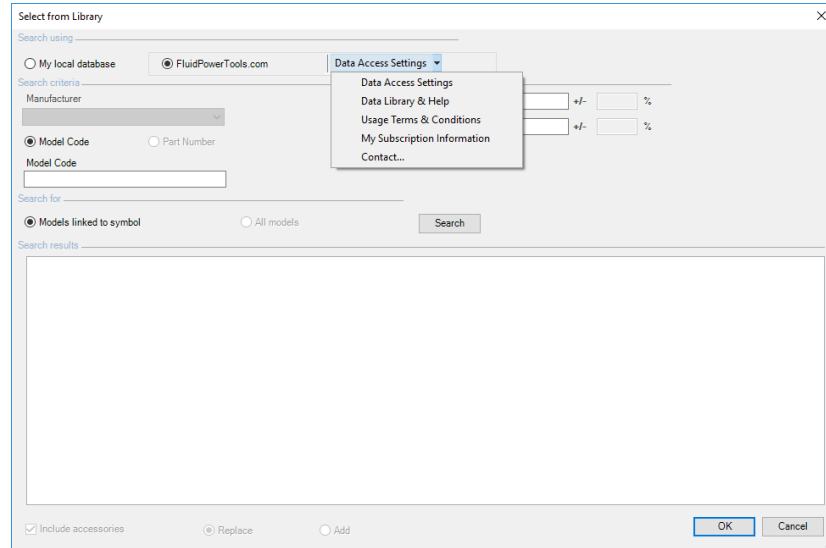

Select from Library - Data Access Settings

Add Accessories

You can add or replace accessories of the model code to the symbol by selecting an appropriate button.

- Select the **Include accessories** check box, and then select **Add**.

The linked accessories of the component model will be added to the selected model.

Replace Accessories

- Select the **Include accessories** check box, and then select **Replace**.

The linked accessories of the component model will be added to the selected model and all accessories linked previously will be delinked.

Saving Model Data into Library

You can save the designed component with customized data in the library.

- Click  on the Model Data caption bar to save custom details in the library.

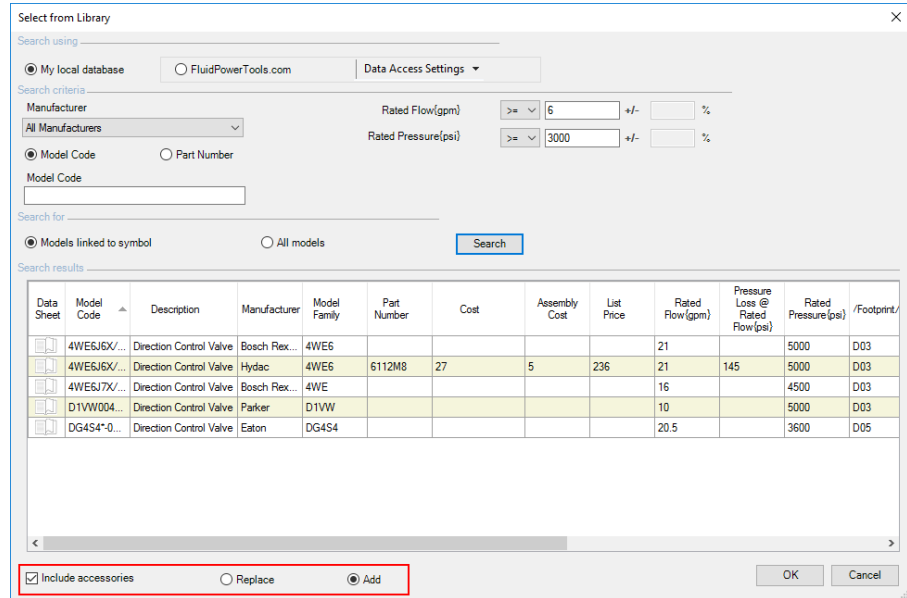

Select from Library

Search using: My local database | FluidPowerTools.com | Data Access Settings

Search criteria:

Manufacturer: All Manufacturers | Rated Flow(gpm): 6 +/- % | Rated Pressure(psi): 3000 +/- %

Model Code: | Part Number: | Model Code:

Search for: Models linked to symbol | All models | Search

Data Sheet	Model Code	Description	Manufacturer	Model Family	Part Number	Cost	Assembly Cost	List Price	Rated Flow (gpm)	Pressure Loss @ Rated Flow (psi)	Rated Pressure (psi)	/Footprint/
	4WE6J5X/...	Direction Control Valve	Bosch Rex...	4WE6					21		5000	D03
	4WE6J5X/...	Direction Control Valve	Hydac	4WE6	6112M8	27	5	236	21	145	5000	D03
	4WE6J7X/...	Direction Control Valve	Bosch Rex...	4WE					16		4500	D03
	D1VW004...	Direction Control Valve	Parker	D1VW					10		5000	D03
	DG4S4*0...	Direction Control Valve	Eaton	DG4S4					20.5		3600	D05

Include accessories | Replace | Add | OK | Cancel

Select from Library with Search results

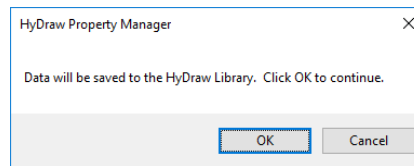

HyDraw Property Manager

Data will be saved to the HyDraw Library. Click OK to continue.

OK | Cancel

Save to Library

5. Pump Motor Adaptor Data - Select from Library

1. Click Circuit > **Edit**  on the HyDraw® CAD ribbon menu.

The HyDraw Property Manager window displays.

2. Select the **adaptor**.

The HyDraw Property Manager displays the properties of the adaptor.

3. Click  on the Model data caption bar to select the Model data from the library.

The Pump/Motor Adaptor dialog box displays. Automatically all the properties of the respective motor and pump populates, and the most appropriate data is selected.

4. Select the required adaptor.
5. Click **OK** to select the adaptor data from the library and populate in the Property Manager.

Note:

- Pump and Motor symbols must be close enough to touch the adaptor both ends.
- The Pump and Motor must have certain properties already defined (E.g. Frame Size, Pump Mount and Shaft length) in order to prompt for a selection.
- You can do an embedded search for a single Motor Frame Size and Pump Mount from a multiple values that are separated by slash (/).
E.g. Motor Frame Size: 145TC/245TC/.. etc.
Pump Mount: SAE 2B/SAE 4B/.. etc.

Select Pump/Motor Adaptor

Motor Frame Size	Pump Mount	
145TC	SAE B 2 bolt	
Shaft Length	Shaft Length	Minimum face to face Length
2.125	1.75	3.875

Available Adaptors

Model Code	Model Family	Description	Manufacturer	Face to Face Length
M056502B	M056502B	Motor/Pump Adapter	Magnalloy	4.6

OK Cancel

Pump/Motor Adaptor Data

Model data

Model Family	
Description	Motor/Pump Adapter
Manufacturer	MAGNALLOY
Model Code	M182582B
Catalog Number	M182582B
Cost	
List Price	
Frame Size	182-256
Pump Mount	SAE 2B
Length (in)	4.6

Accessories

Property Manager: Model data

6. Accessories

The Accessories section displays the details of accessories assigned with the item. This section also displays all documents and CAD files linked with the accessory.

7. Select from Library

Fetch required accessories for your component from the library.

1. Click  on the Accessories caption bar to open Select Accessories from Library dialog box.
2. Select Accessories or Components.
3. Select the required manufacturer and component type.
4. To refine the search, type the Model Code, and then click **Search**.

All available accessories of the selected component type display in the Available accessories pane.

5. Define more criteria,
 - For precise search, define custom search parameters.
 - Click  to view the Select Property box, which displays common properties.
 - Select the property you want to assign.
 - Click OK.

6. Click **Search**.

All available accessories of the selected component type display in the Available accessories pane.

7. Select the model code you want to add to your circuit.
8. Click **Add**.

The added model codes display in the Selected accessories pane.

9. Select the model code and click **Remove** to remove the selected model code from the selected accessories pane.
10. Click **OK**.

All the selected accessories are added to the component and displayed in the Accessories pane on the Selected item tab page.

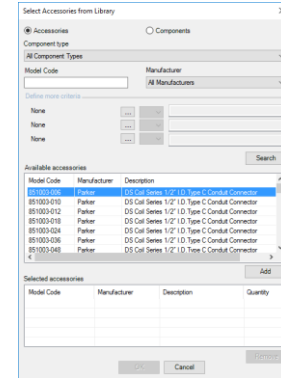

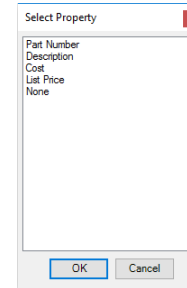

Fetch Accessories from Library



Selected accessories

Add New Accessories

Add new accessories to the selected item and save in the library.

1. Click  on the Accessories caption bar.
The Add New Accessory dialog box displays.
2. Select Accessories/Components.
3. Select the appropriate component type you want to add.
4. Click **OK**.
The accessories are assigned to the component and displayed in the Accessories pane.
5. Click  to expand the newly added accessories menu.
6. Enter the required data in the appropriate text box.

Save Accessories

Save the newly added accessories to the component.

1. Click  on the Accessories caption bar.
The Save to Library dialog box displays.
2. Click **OK**.
The new accessories are saved.

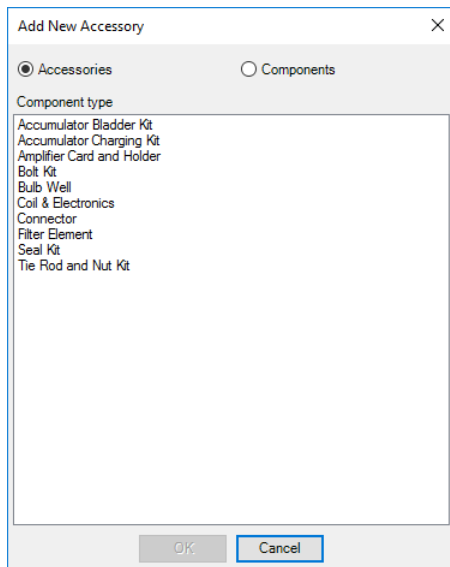

Add New Accessory window

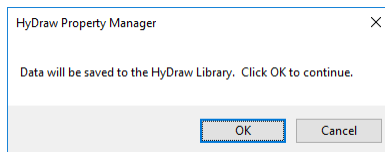

Save to HyDraw Library message box

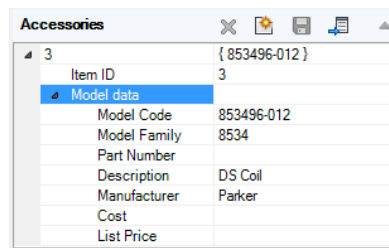

Accessories section

Delete Accessories

1. Select the accessory you want to remove.
2. Click  on the **Accessories** caption bar to delete the accessory.

The accessory is deleted from the component.

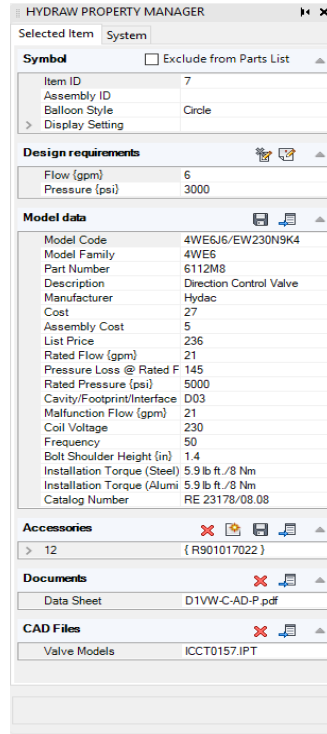



The screenshot shows the HYDRAW PROPERTY MANAGER dialog box. The 'Accessories' section is expanded, showing a list of accessories. The first accessory is selected, and a red 'X' icon is visible next to it, indicating it is being deleted. The 'Accessories' section also shows a list of accessories, with the first one selected and a red 'X' icon next to it.

HYDRAW PROPERTY MANAGER	
Selected Item System	
Symbol <input type="checkbox"/> Exclude from Parts List	
Item ID	7
Assembly ID	
Balloon Style	Circle
Display Setting	
Design requirements	
Flow (gpm)	6
Pressure (psi)	3000
Model data	
Model Code	4WE6J6/EW230N9K4
Model Family	4WE6
Part Number	6112M8
Description	Direction Control Valve
Manufacturer	Hydac
Cost	27
Assembly Cost	5
List Price	236
Rated Flow (gpm)	21
Pressure Loss @ Rated F	145
Rated Pressure (psi)	5000
Cavity/Footprint/Interface	D03
Malfunction Flow (gpm)	21
Coil Voltage	230
Frequency	50
Bolt Shoulder Height (in)	1.4
Installation Torque (Steel)	5.9 lb ft./8 Nm
Installation Torque (Alumi)	5.9 lb ft./8 Nm
Catalog Number	RE 23178/08.08
Accessories	
12 { R901017022 }	
Documents	
Data Sheet	D1VW-C-AD-P.pdf
CAD Files	
Valve Models	ICCT0157.IPT

Accessories deleted from library

8. Documents

Documents section displays the documents linked with the selected component model. You can delete and link documents from library.

- Click  on the **Documents** caption bar to delete the linked document.
- Click  **Select from library** to link new document to the selected component model.

HYDRAW PROPERTY MANAGER

Selected Item | System

Symbol Exclude from Parts List ▲



Item ID	7
Assembly ID	
Balloon Style	Circle
Display Setting	

Design requirements  ▲



Flow (gpm)	6
Pressure (psi)	3000

Model data  ▲



Model Code	4WEEJ6/EW230N9K4
Model Family	4WEE6
Part Number	6112M8
Description	Direction Control Valve
Manufacturer	Hydac
Cost	27
Assembly Cost	5
List Price	236
Rated Flow (gpm)	21
Pressure Loss @ Rated F	145
Rated Pressure (psi)	5000
Cavity/Footprint/Interface	D03
Malfunction Flow (gpm)	21
Coil Voltage	230
Frequency	50
Bolt Shoulder Height (in)	1.4
Installation Torque (Steel)	5.9 lb ft./8 Nm
Installation Torque (Alumii	5.9 lb ft./8 Nm
Catalog Number	RE 23178/08.08

Accessories   ▲

> 12 (R901017022)

Documents   ▲

Data Sheet	D1VW-C-AD-P.pdf
------------	-----------------



CAD Files   ▲

Valve Models	ICCT0157.IPT
--------------	--------------

Documents Section

9. CAD Files

The CAD Files section displays the CAD files linked with the selected component model. You can delete and link CAD files from the library.



- Click  on the **CAD Files** caption bar to delete the linked CAD files.
- Click  **Select from library** to link new CAD files to the selected component model.

HYDRAW PROPERTY MANAGER



Selected Item System

Symbol Exclude from Parts List ▲





Item ID	7
Assembly ID	
Balloon Style	Circle
> Display Setting	

Design requirements   ▲



Flow (gpm)	6
Pressure (psi)	3000

Model data   ▲



Model Code	4WE6J6/EW230N9K4
Model Family	4WE6
Part Number	6112M8
Description	Direction Control Valve
Manufacturer	Hydac
Cost	27
Assembly Cost	5
List Price	236
Rated Flow (gpm)	21
Pressure Loss @ Rated F	145
Rated Pressure (psi)	5000
Cavity/Footprint/Interface	D03
Malfunction Flow (gpm)	21
Coil Voltage	230
Frequency	50
Bolt Shoulder Height (in)	1.4
Installation Torque (Steel)	5.9 lb ft./8 Nm
Installation Torque (Alumi	5.9 lb ft./8 Nm
Catalog Number	RE 23178/08.08

Accessories     ▲

> 12 { R901017022 }

Documents   ▲

Data Sheet	D1VW-C-AD-P.pdf
------------	-----------------

CAD Files   ▲

Valve Models	ICCT0157.IPT
--------------	--------------

CAD File Section

28.Edit Properties

Edit various properties of a symbol, external port, envelope line, connection line and sub-system.
It displays the HyDraw® Property Manager, where the properties can be added and modified.

1. Click Circuit > **Edit**  on the HyDraw CAD ribbon menu.

The HyDraw Property Manager window displays.

2. Edit the required properties of a symbol.
3. The Display Setting can display multiple properties, if already defined in the Library Manager.

Symbol		<input checked="" type="checkbox"/> Include in Parts List
Item ID	4	
Assembly ID		
Balloon Style	Circle	
Display Setting		
Cylinder Size	Show	
Port Size Ext	Show	
Port Size Ret	Show	
Accessory ID	Show	

HyDraw Property Manager - Display Settings

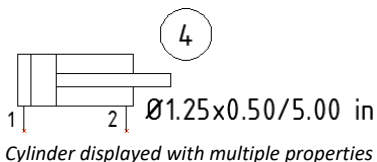

HYDRAW PROPERTY MANAGER	
Selected Item System	
Symbol <input type="checkbox"/> Exclude from Parts List	
Item ID	7
Assembly ID	
Balloon Style	Circle
Display Setting	
Design requirements	
Flow (gpm)	6
Pressure (psi)	3000
Model data	
Model Code	4WE6J6/EW230N9K4
Model Family	4WE6
Part Number	6112M8
Description	Direction Control Valve
Manufacturer	Hydac
Cost	27
Assembly Cost	5
List Price	236
Rated Flow (gpm)	21
Pressure Loss @ Rated F	145
Rated Pressure (psi)	5000
Cavity/Footprint/Interface	D03
Malfunction Flow (gpm)	21
Coil Voltage	230
Frequency	50
Bolt Shoulder Height (in)	1.4
Installation Torque (Steel)	5.9 lb.ft./8 Nm
Installation Torque (Alumi)	5.9 lb.ft./8 Nm
Catalog Number	RE 23178/08.08
Accessories	
12	(R901017022)
Documents	
Data Sheet	D1VW-C-AD-P.pdf
CAD Files	
Valve Models	ICCT0157.IPT

HyDraw Property Manager

29. Copy Properties

Copy component data, design requirements, accessories and linked data properties from one component symbol to another component symbol of the same category.
Copy the properties of external ports and envelope data.

Also copy sub-system data, design requirements, accessories and linked data properties from one sub-system to another sub-system of the same category.

1. Click  on the HyDraw® CAD ribbon menu.
The Select Source Symbol prompt displays.
2. Select the source symbol.
The Select Destination Symbols prompt displays.
3. Select a single or multiple destination symbols.
4. After completion of selection, press the **Enter** key.
The Copy Property dialog box displays.
5. Select the required design requirements, if you want to copy from the **Design requirements** checklist box.
6. Select the **Design Notes** checkbox, if you want to copy the design notes to the destination symbol.
7. Select the **Include accessories** checkbox, if you want to copy the accessories to the destination symbol.
8. Select the Include **Linked Documents** and **Linked CAD Files** checkbox, if you want to copy the linked Documents and CAD Files to the destination symbol.
9. Click **OK**.
The properties are copied to the destination symbol(s).

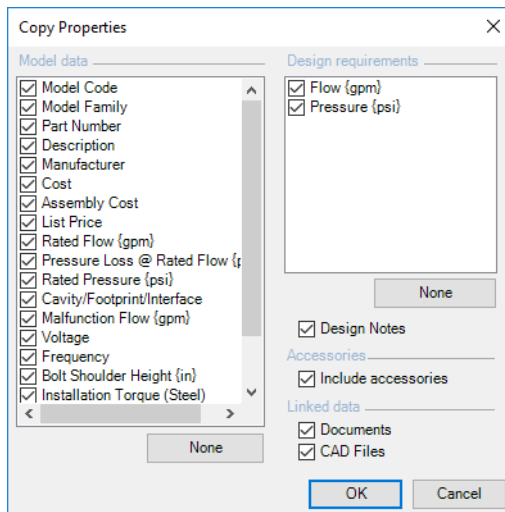

Copy Properties

30.Refresh Properties

Update the property values of sub-systems & components from HyDraw® Library.

1. Click Circuit >  on the HyDraw CAD ribbon menu.

The Select symbols prompt displays.

2. Select single or multiple symbols.
3. After completion of selection, press the **Enter** key.

The Specify Items Included [Sub-Systems & Components/ Accessories/ Include All/ More Options] <Include All> prompt displays.

Sub-Systems & Components further prompts, Include Child Items [Yes No] <Yes>.

4. Specify the items to be refreshed.
5. Select individual properties to Refresh or **Select All**.
6. Click **OK**.

The Update message box displays.

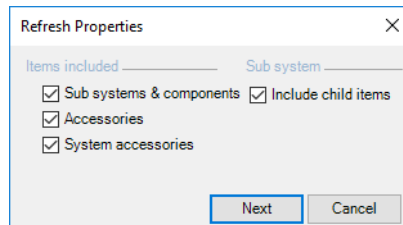

Refresh Properties – Specify Items

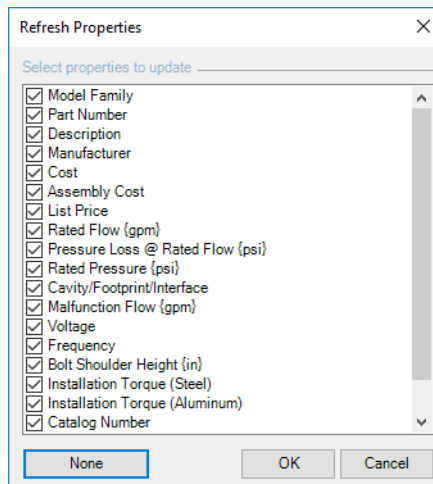

Refresh properties – Properties Selection

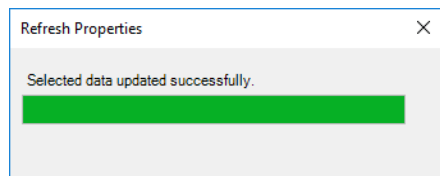

Successful Update message

31. Update Property List

Update the properties of the Sub-systems & components, external ports, connection lines and accessories from the HyDraw® Library.

1. Click Circuit >  on the HyDraw CAD ribbon menu.
The Select symbols and connections prompt displays.
2. Select single or multiple symbols, external ports, connection lines.

After completion of selection, press the **Enter** key.

The Specify Items Included [Sub-Systems & Components/ Accessories/ Include All/ More Options] <Include All> prompt displays.

Sub-Systems & Components further prompts, Include Child Items [Yes No] <Yes>.

More Options further Prompts, Include Components [Yes No] <Yes>. Include Component Accessories [Yes No] <Yes>. Include System Accessories [Yes No] <Yes>.

3. Select the required option.
The Update Properties List dialog box displays.
4. Select the items to be included:
 - Add new model and design properties
 - Add new display formats
 - Update property and display format definitions
 - Delete unused properties and display formats
5. Click **Update**.
The Update Property List message box displays the status.
6. Click **OK** to apply and exit.

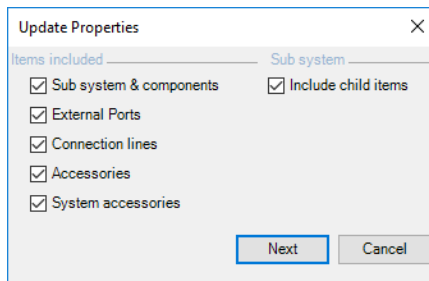

Update Properties – Specify Items

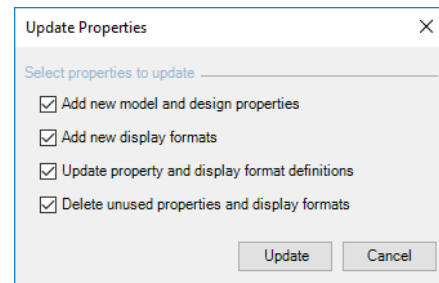

Update Properties List

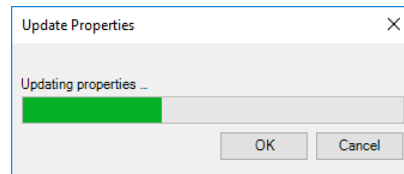

Update Status

32. Purge Properties

Clear the properties values of a symbol.

1. Click Circuit > Edit > **Purge** on the HyDraw® CAD ribbon menu.

The Select Symbols prompt displays.

2. Select single or multiple symbols.
After the completion of selection, press the **Enter** key.

The Specify items included [Sub-Systems & Components/Accessories/Include all/More options] <Include All> prompt displays.

Sub-Systems & Components further prompts,

Include Child Items [Yes No] <Yes>.

More Options further Prompts,

Include Components [Yes No] <Yes>.

Include Component Accessories [Yes No] <Yes>.

Include System Accessories [Yes No] <Yes>.

3. Select the required option.

The Purge Properties dialog box displays.

4. Select the properties that are to be purged and Click **OK**.

A warning message box displays.

5. Click **OK** to continue
or
Click **Cancel** to exit.

The selected properties are purged.

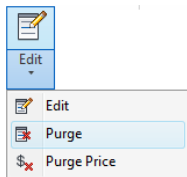

Purge Property Sub Menu

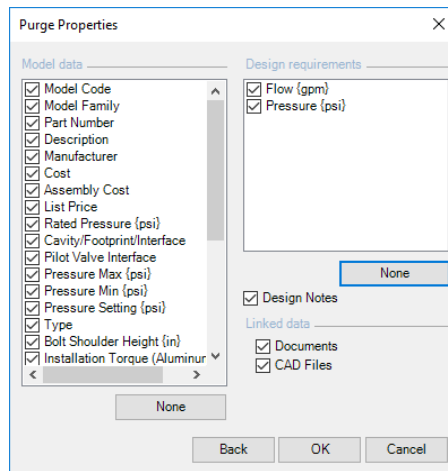

Purge Properties dialog box

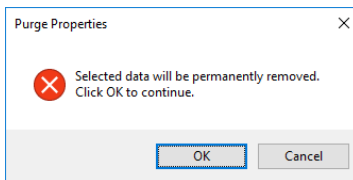

Warning message box

HYDRAW PROPERTY MANAGER

Selected Item System

Symbol Exclude from Parts List ▲

Item ID	7
Assembly ID	
Balloon Style	Circle
> Display Setting	

Design requirements ▲

Flow (gpm)	6
Pressure (psi)	3000

Model data ▲

Model Code	4WE6J6/EW230N9K4
Model Family	4WE6
Part Number	6112M8
Description	Direction Control Valve
Manufacturer	Hydac
Cost	27
Assembly Cost	5
List Price	236
Rated Flow (gpm)	21
Pressure Loss @ Rated F	145
Rated Pressure (psi)	5000
Cavity/Footprint/Interface	D03
Malfunction Flow (gpm)	21
Coil Voltage	230
Frequency	50
Bolt Shoulder Height (in)	1.4
Installation Torque (Steel)	5.9 lb ft./8 Nm
Installation Torque (Alumi	5.9 lb ft./8 Nm
Catalog Number	RE 23178/08.08

Accessories ▲

> 12 { R901017022 }

Documents ▲

Data Sheet	D1VW-C-AD-P.pdf
------------	-----------------

CAD Files ▲

Valve Models	ICCT0157.IPT
--------------	--------------

HyDraw Property Manager before purge property

HYDRAW PROPERTY MANAGER

Selected Item System

Symbol Exclude from Parts List ▲

Item ID	4
Assembly ID	
Balloon Style	Circle
> Display Setting	

Design requirements ▲

Flow (gpm)	
Pressure (psi)	

Model data ▲

Model Code	
Model Family	
Part Number	
Description	
Manufacturer	
Cost	
Assembly Cost	
List Price	
Rated Flow (gpm)	
Pressure Loss @ Rated Flow	
Rated Pressure (psi)	
Cavity/Footprint/Interface	
Malfunction Flow (gpm)	
Voltage	
Frequency	
Bolt Shoulder Height (in)	
Installation Torque (Steel)	
Installation Torque (Aluminum	
Catalog Number	

Accessories ▲

> 12

Documents ▲

CAD Files ▲

HyDraw Property Manager after purge property

33.Purge Price Data

Clear the price data values in the Drawing.

1. Click Circuit > Edit > **Purge Price Data** on the HyDraw® CAD ribbon menu.

The components in the schematic are selected automatically.

The Purge Price Data warning message box displays, indicating that the price data will be removed permanently from all the components in the drawing.

2. Select **Include child items**, if you want to remove the price data from the sub-system child items.
3. Click **OK**, if you want to continue.

On completion, prompts a message - Price data removed successfully.

4. Click **OK**.

Note:

Save the schematic with a different file name and/or location before removing price information for your convenience and future reference.

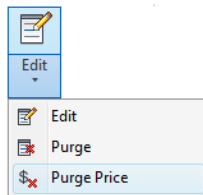

Purge Price sub menu

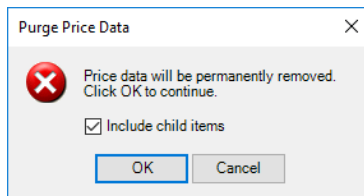

Purge Price Data warning box

34. Edit Solenoid Information

Edit the Solenoid ID of the selected symbol and function in the drawing. It does not affect the master symbol in the HyDraw® library.

1. Select a valid HyDraw directional control valve symbol with the solenoid name.
2. Click Circuit > **Solenoid Info**  on the HyDraw CAD ribbon menu.

The Edit Solenoid Information dialog box displays.

3. In the Solenoid ID column, edit the **ID**, if already available, or enter a new ID.

The Show check box changes the visibility of the ID and function for the selected symbol.

4. In the Available functions section, enter the **Function** name and click the **Add** button.

*The **Update** button allows editing the existing function.*

- Select the solenoid name.
 - Select the function.
 - Click the Add selected function button.
 - The selected function is added to the selected solenoid name.
5. Click **OK** to close the window and to enable changes to take effect.

Note:

1. Changes affect only the symbol in the drawing and not the master symbol in the HyDraw Library.
2. Solenoid IDs must be Unique to create Solenoid Actuation Chart, without Item ID.

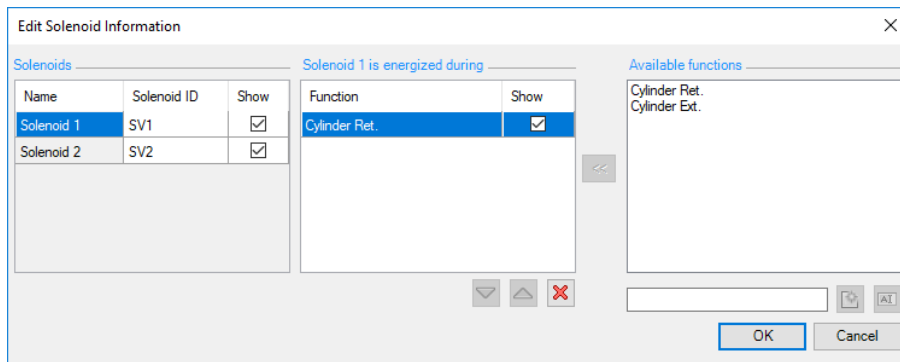

Opened symbol stencil for edit

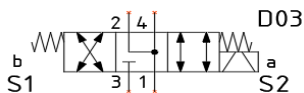

Symbol before edit

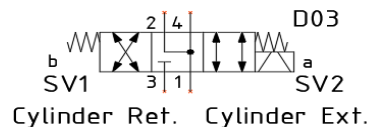

Symbol after edit

35. Update from Excel

Fetch the data from the ERP data file in the Excel format.

1. Click **Circuit** >  on the HyDraw® CAD ribbon menu.

The Select Symbols prompt displays

2. Select single or multiple symbols.
After the completion of selection, press the **Enter** key.

The Specify items included [Sub-Systems & Components/Accessories/Include all/More options] <Include All> prompt displays.

Sub-Systems & Components further prompt: Include Child Items [Yes No] <Yes>.

*More Options further Prompt: Include Components [Yes No] <Yes>.
Include Component Accessories [Yes No] <Yes>.
Include System Accessories [Yes No] <Yes>.*

3. Select the required option.

*The Update from Excel dialog box displays.
The columns get populated with the matching Model codes values.
Partially matching Model Codes are displayed with the Select link.*

4. Click the **Select** link.

The Select Model dialog box displays.

5. Select the available Model Code, as required.
6. Click **OK**.

The highlighted cells indicate the matching values with the selected sub-systems, components and accessories.

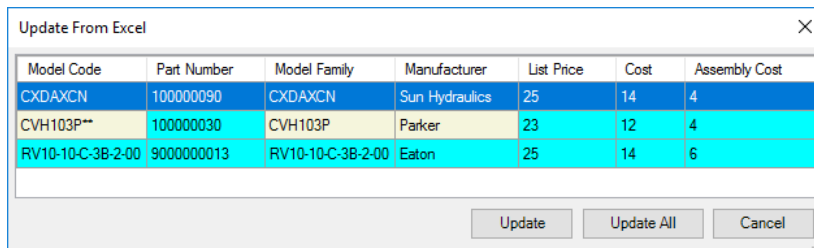

Update from Excel

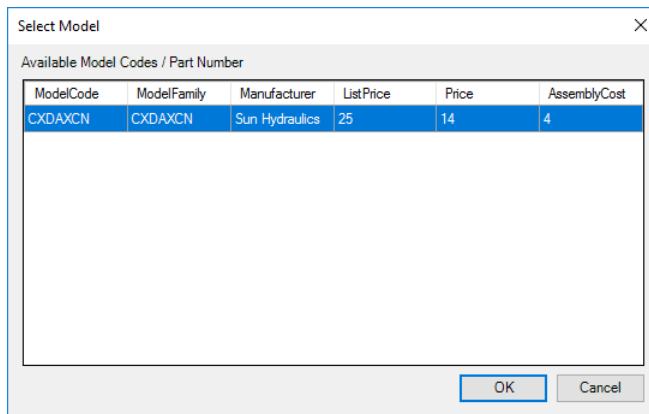

Select Model dialog box

7. Click **Update** to update the selected row.
8. Click **Update All** to update all the rows in the drawing.

The selected models are updated to the selected symbols properties

Modify Symbols

HyDraw CAD 2019 Sample Circuit.dwg

Circuit System Services Home Insert Annotate Parametric View Manage Output Help
 Symbol More Auto Connect Envelope Gauge Orifice Disc
 Symbol Port Terminator Stretch Match Merge Move Rotate Left Rotate Right Flip Horizontal Flip Vertical Delete Symbol Edit Symbol Edit Symbol Port Stack Symbols Symbol Ports Port Names Edit Refresh Update Solenoid Update from Excel Options
 Insert Modify Connection Modify Symbols Align Properties Setup

Start Sample Circuit* x

4 3 2
 #4 SAE MR #6 SAE R #6 SAE C #4 SAE MC
 20 gsu T-13A C10-2 2500 psi FC10-2
 SV1 SV2
 Cylinder Ret. Cylinder Ext. P2 SAE
 #8 SAE
 1800 psi #8 SAE
 P1 #8 SAE
 1 1/4" SAE R12
 #8 SAE
 #10 SAE #6 SAE #8 SAE
 A B
 4 3 2

ITEM ID	QTY	MODEL CODE	DESCRIPTION
1	3	DYN-OF-F250ASAE	PRESSURE GAGE
2	1	SP2700	PUMP MOTOR AS
3	1	F5120	HOSE
4	1	P30-00	SUCTION STRAINER
5	2	AS-B092-N	BRECK A/TNG P
6	1	CYD-VAN	SOLENOID VALVE
7	1	LV6E-MX/EW230HW4	DIRECTION CONTR
8	1	5045-650BPG620	FILTER
9	1	SD-01-DNH	NEEDLE VALVE
10	1	LS-67	PLUG & THERP SWITCH
11	1	BR20	FILTER/BREATHER
12	1	RW0-D17022	SOLENOID VALVE

ITEM ID	PORT TYPE	DESCRIPTION
BR_C_LV1_R	SAE O-RING	#6 SAE
MC_MP_HR	SAE O-RING	#4 SAE
P1_P2_FR1_T	SAE O-RING	#8 SAE
TR1	SAE O-RING	#10 SAE

NET NAME	NET LIST	NET PRESSURE (PSI)
NET-1	MC, 4-2, C	3000
NET-2	F-T, T, SA-2	1500
NET-3	T-5, P2, P1, HP, SA-1	3500
NET-4	MR, 4-2, R, SB-1	3000
NET-6	SA, 7-8	1500
NET-7	SA-1, SB-2, 7-8	4000

FUNCTION	7-SV1	7-SV2	HOSE ID
CYLINDER EXT.	<input type="checkbox"/>	<input type="checkbox"/>	3
CYLINDER RET.	<input type="checkbox"/>	<input type="checkbox"/>	

INSERT LIST	DATE	BY	CHKD
DR: 3RD			
DESIGN			
ANGLE			
PRODUCTION			
SYMBOL HERE			

THE INFORMATION CONTAINED
 IN THIS DOCUMENT IS THE
 SOLE PROPERTY OF HYDRA
 LICA CORPORATION. IT IS
 TO BE USED FOR THE
 ORDER ONLY AND NOT FOR
 REPRODUCTION.

MODEL LAYOUT1 + PAPER MODEL 1:1

- 36 Move Symbol
- 37 Align Symbols
- 38 Rotate Symbols
- 39 Flip Symbols
- 40 Align Symbol Ports
- 41 Align External Port Names
- 42 Edit Symbol Port
- 43 Edit in Place
- 44 Delete a Symbol
- 45 Stack Symbols
- 46 Show/Hide Port Names
- 47 Show/Hide Design Notes
- 48 Edit Design Notes
- 49 Edit Jumping Reference
- 50 Find Jumping Reference

36.Move Symbol

Move a symbol from one point to another in the drawing.

1. Click Circuit > **Move**  on the HyDraw® CAD ribbon menu.

The Select Symbol to Move prompt displays.

2. Select the symbol.

The Specify Base point or [Displacement] <Displacement> prompt displays.

3. Specify the base point of the symbol.

The Specify second point prompt displays.

4. Specify the second point.

The symbol is moved to the new location.

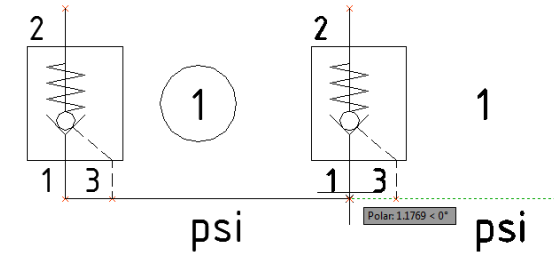

Move Symbol

37.Align Symbols

Align multiple symbols with another symbol, horizontally or vertically, from left, right, or middle.

1. Click Circuit > **Align Symbols**  on the HyDraw® CAD ribbon menu.

The Select Symbols to Move prompt displays.

2. Select a single symbol or multiple symbols. After completion of selection, press the **Enter** key.

The Select Symbol to Align With prompt displays.

3. Select the symbol.

The Align [Tops/Middles/ Bottoms/ Lefts/ Centers/ Rights] prompt displays.

4. Select the required alignment and press the **Enter** key.

The symbols get aligned with the selected symbol accordingly.

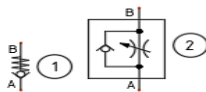

Symbols aligned from bottom

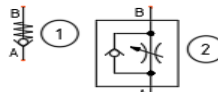

Symbols aligned from top

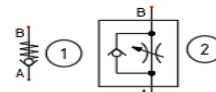

Symbols aligned from top

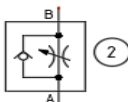

Symbols aligned from right

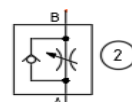

Symbols aligned from left

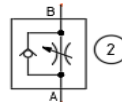

Symbols aligned from middle

38. Rotate Symbols

Rotate a symbol, 90 degrees to its left or right.

The associated text is constrained to remain horizontal.

1. Rotate Left

1. Click Circuit > **Rotate Left**  on the HyDraw® CAD ribbon menu.

The Select Symbols prompt displays.

2. Select a single or multiple symbol.
After completion of selection, press the **Enter** key.

The symbol rotates 90 degrees to its left.

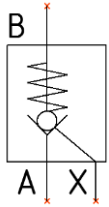

Select a symbol

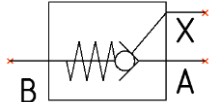

Rotate symbol to the left

2. Rotate Right

1. Click Circuit > **Rotate Right**  on the HyDraw CAD ribbon menu.

The Select Symbols prompt displays.

2. Select a single or multiple symbol.
After completion of selection, press the **Enter** key.

The symbol rotates 90 degrees to its right.

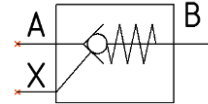

Rotate symbol to the right

39. Flip Symbols

Flip a symbol horizontally or vertically. The associated text is constrained to remain horizontal.

1. Flip Horizontal

1. Click Circuit >  **Flip Horizontal** from the Modify Symbol option on the HyDraw® CAD ribbon menu.

The Select Symbols command displays.

2. Select a single or multiple symbol.
After completion of selection, press the **Enter** key.

The symbol flips horizontally.

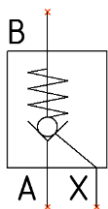

Symbol inserted in the drawing

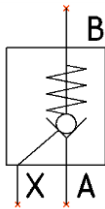

Symbol after horizontal flip

2. Flip Vertical

1. Click Circuit >  **Flip Vertical** from the Modify Symbol option on the HyDraw CAD ribbon menu.

The Select Symbols command displays.

2. Select a single or multiple symbol.
After completion of selection, press the **Enter** key.

The symbol flips vertically.

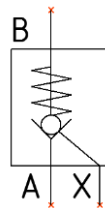

Symbol inserted in the drawing

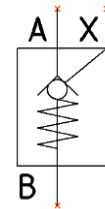

Symbol after vertical flip

40. Align Symbol Ports

Align ports of different symbols horizontally or vertically.

1. Click Circuit > **Align Symbol Ports**  on the HyDraw® CAD ribbon menu.

The Select Symbols Port to Move prompt displays.

2. Select a port by clicking on the red cross or the port name.

The Select Symbol Port to Align With prompt displays.

3. Select a port by clicking on the red cross or the port name.

The Align on [X-axis/ Y-axis] command displays on the command window.

4. Enter the appropriate axis and press the **Enter** key.

The symbols are aligned with reference to their ports.

Note:

When aligning external ports (that are aligned with the envelope) to symbol ports, in some cases the envelope line may pass through the external ports. In such cases, manually adjust the envelope line.

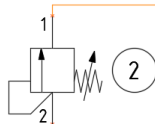
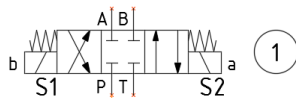

Before

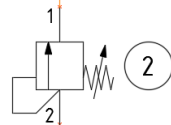
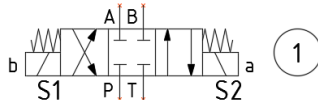

After

Symbol ports aligned vertically

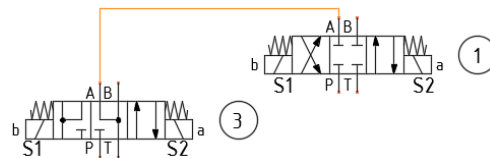

Before

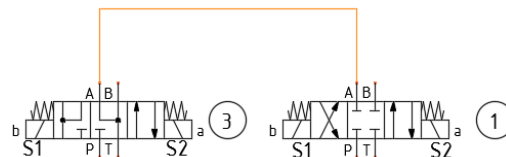

After

Symbol ports aligned horizontally

41.Align External Port Names

Align port names of all the selected ports horizontally or vertically along the envelope line.

1. Click Circuit > **Align External Port**

Names  on the HyDraw® CAD ribbon menu.

The Select System Ports prompt displays.

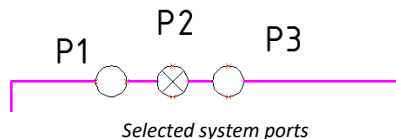

2. Select ports to align port names.
After completion of selection, press the **Enter** key.

The symbol-port names get aligned.

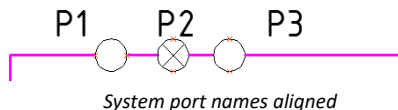

In this selection, the left and bottom port name is taken as reference and all other system port names are aligned in a single line parallel to the envelope.

42.Edit Symbol Port

*Edit the port name of the selected symbol in the drawing.
It does not affect the master symbol in the HyDraw® library.*

1. Click Circuit > **Edit Symbol Port**  on the HyDraw CAD ribbon menu.

The Select Symbol prompt displays.

2. Select the symbol port to be renamed.

The Edit Port dialog box displays.

3. Type the new name in the **Name** column and the optional **Other Name** column.

4. To delete the port, click .

5. Select **Name/Other Name** in the Display option.

6. Click **OK**.

The name or the other name of the port displays with the symbol.

If both the names are selected, then dual port names are displayed.

Note:

The changes affect only the symbol in the drawing and not the master symbol in the HyDraw Library.

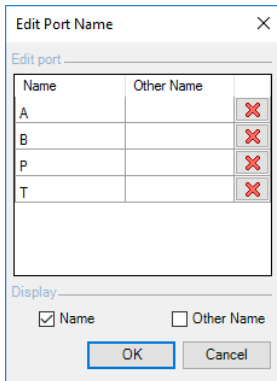

Name	Other Name	Delete
A		X
B		X
P		X
T		X

Edit Port Name

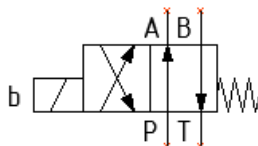

Symbol with unedited ports

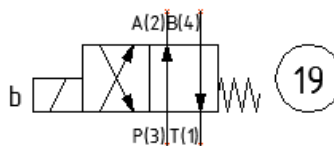

Symbol with Dual port names

43.Edit in Place

1. Symbol

Edit the selected symbol in the drawing.

It does not affect the master symbol in the HyDraw® library.

1. Click Circuit > **Edit symbol**  on the HyDraw CAD ribbon menu.

The Select Symbol to Edit prompt displays.

2. Select the symbol from the drawing you want to edit.

The symbol opens in the Block Editor.

3. Edit the symbol using the Block Authoring Palettes.

4. Click **Close Block Editor** to close the window after you make the changes.

Note:

The changes affect only the symbol in the drawing and not the master symbol in the HyDraw Library.

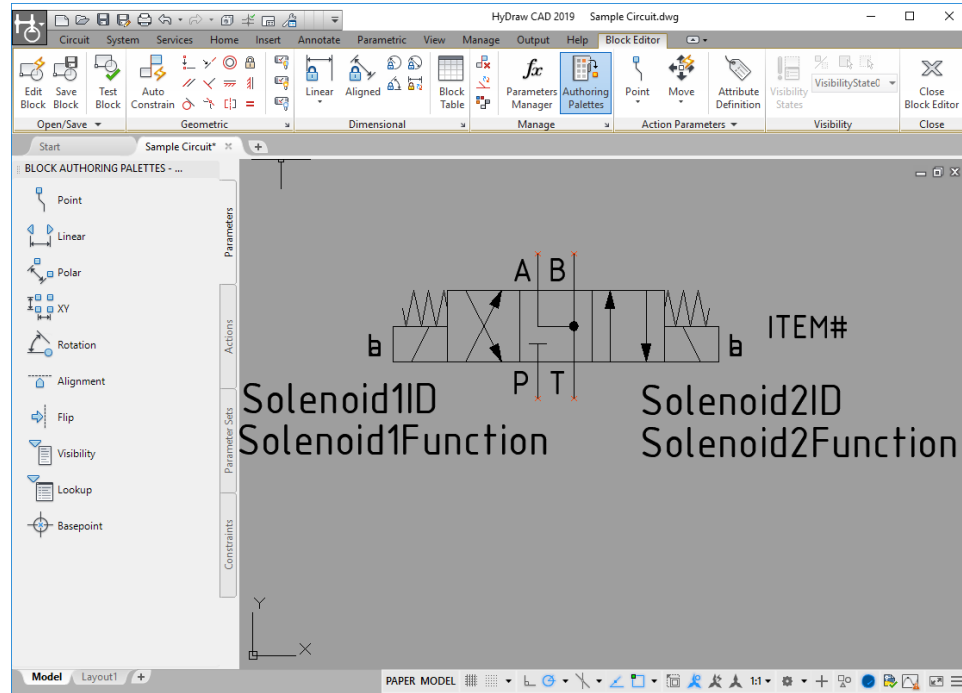

Symbol opens in Block Editor window

44.Delete a Symbol

Delete a symbol from the drawing.

1. Click Circuit> **Delete**  on the HyDraw® CAD ribbon menu.

The Select Symbols prompt displays.

2. Select a single symbol or multiple symbols to delete.
After completion of selection, press the **Enter** key.

The selected symbols and the connections are deleted.

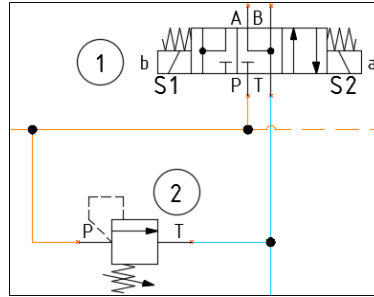

Circuit Before Deleting a Symbol

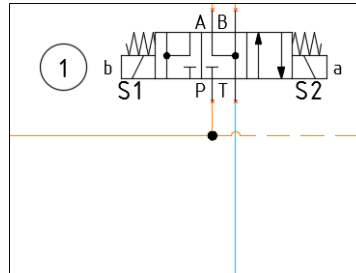

Circuit After Deleting a Symbol

45.Stack Symbols

Stack symbols horizontally or vertically.

1. Click Circuit > **Stack**  on the HyDraw® CAD ribbon menu.

The Select Symbols to Stack prompt displays.

2. Select multiple symbols to stack.
After completion of selection, press the **Enter** key.

The Stack direction [Up/Down/Right/Left] <Up>: prompt displays.

3. Select the direction.

The symbols are stacked, accordingly.

Note:

- Port 'P' is the default alignment guide.
- If there is no 'P' port, then port 'X' is used (e.g. Slip-in cover).
In all other cases, Symbol Alignment box center is used to align the symbols.

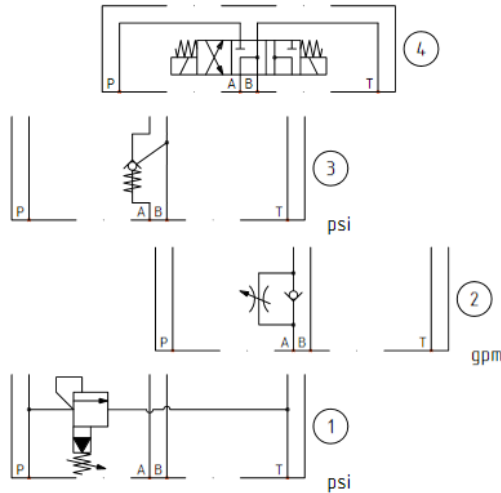

Symbols to Stack

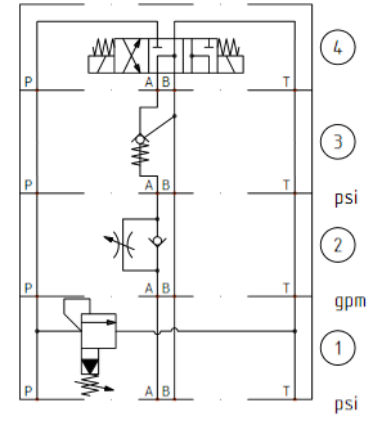

Symbols after Stacking

46.Show/Hide Port Names

Toggle between ON/OFF name of the ports in the drawing.

1. Click System > **Port Name**  on the HyDraw® CAD ribbon menu.

The Select Symbols prompt displays.

2. Select a single symbol or multiple symbols.
After completion of selection, press the **Enter** key.

*Enter Option [Show/Hide] <Hide>:
prompt displays.*

3. Enter the required option.

Show: *The names of the ports in the symbols are shown.*

Hide: *The names of the ports in the symbols are hidden.*

Toggle between ON/OFF names of the ports in the drawing.

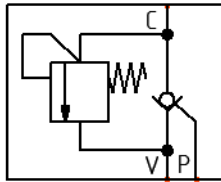

Symbol before

psi

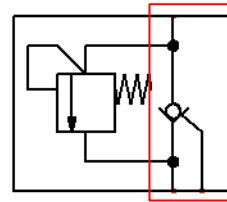

Symbol after hiding port name

psi

47.Show/Hide Design Notes

Toggle between ON/OFF design notes icon in the drawing.

Click System > **Design Notes**  on the HyDraw® CAD ribbon menu.

All the Design notes icons of the drawing will be hidden or shown per its original status (Toggle action).

Note:

You can edit Design notes by double clicking the icon.

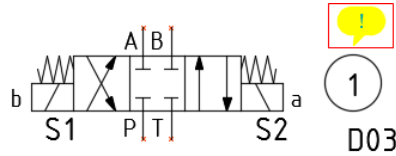

Symbol showing the Design Notes icon

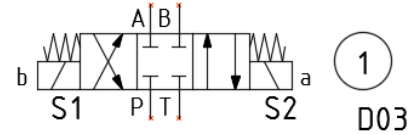

Symbol with the hidden Design Notes icon



48.Edit Design Notes

Edit the design notes of the symbol in the drawing. The changes do not affect the master symbol in the HyDraw® library

1. Double click  the Design notes icon of the symbol in the drawing.

The edit design note text box displays.

By default, the design notes icon will be in the Read only mode.

2. Click the edit button  to open in the writable mode.
3. Edit the text and click  to save.
4. Click  button to close.

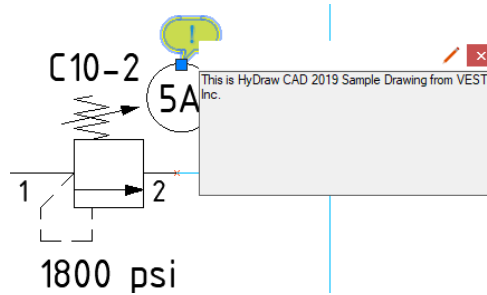

Symbol with Design Notes

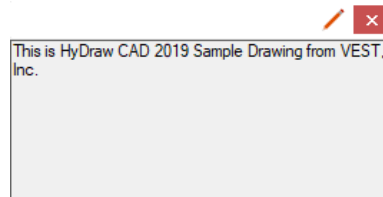

Edit Design Note

49. Edit Jumping Reference

Modify the jumping reference details in the drawing.

1. Click Circuit >  **Edit Jumping Reference** on the HyDraw® CAD ribbon menu.
Or Double click to edit the required jumping reference.

The Select Jumping Reference prompt displays.

2. Select the required jumping reference to modify.

The Jumping Reference dialog box displays.

3. Enter the required **Name** of jumping reference.
4. Select the required **Circuit type** from the drop-down list,

If the Use circuit type option is selected in the HyDraw Options > Connection > Jumping Reference.

5. Enter the required **Destination sheet**.

6. Enter the required **Grid square**,

If the Use grid square option is selected in the HyDraw Options > Connection > Jumping Reference.

7. Click **OK**.

The jumping reference is automatically inserted vertically or horizontally on the unconnected end of a connection line with modified details.

Note:

You cannot modify jumping reference name, when more than one pair of same name exists in the drawing.

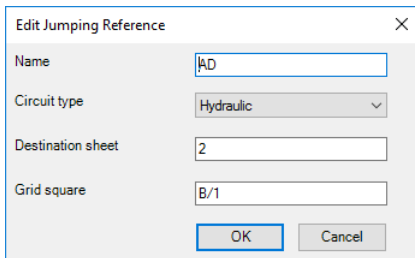

Name	AD
Circuit type	Hydraulic
Destination sheet	2
Grid square	B/1

OK Cancel

Edit Jumping Reference dialog

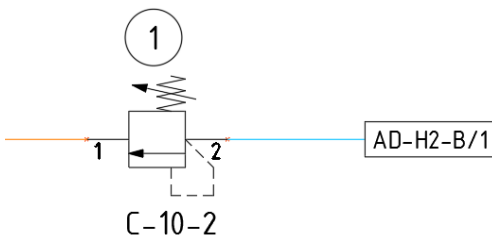

Before modifications of jumping reference

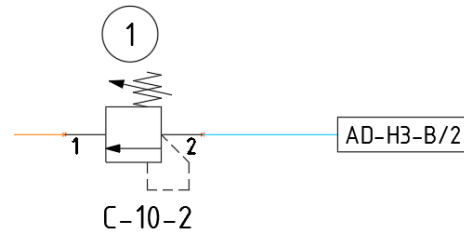

After modifications of jumping reference

50. Find Jumping Reference

Locates the matching pair of jumping reference in the drawing.

1. Click Circuit >  **Find Jumping Reference** on the HyDraw® CAD ribbon menu.
The Select Jumping Reference prompt displays.
2. Select the jumping reference which you want to locate a matching pair in the drawing.

HyDraw automatically zooms to display the matching pair of jumping reference in the drawing.

A warning message box displays, when matching pair is not available in the drawing.

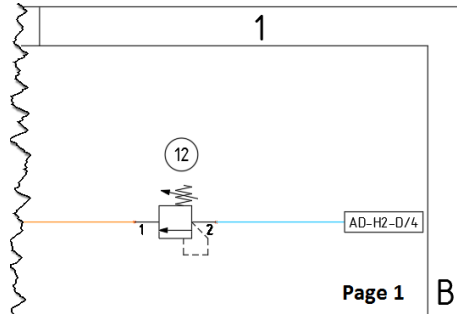

Locate matching pair of jumping reference

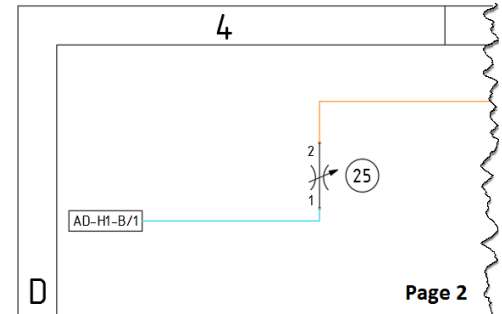

Annotations

HyDraw CAD 2019 Sample Circuit.dwg

Circuit System Services Home Insert Annotate Parametric View Manage Output Help
 Height Rotate Property Display Format Design Notes Port Names Balloon Item Hose Parts Ports Hose Actuation Net Docs CAD Files MDTools Convert to HyDraw Update Drawing Schematic Check Insert Title Block Edit Title Block Unit Converter
 Property Text Show/Hide ID Lists Collate Export Convert Check Title Block Calculator

Start Sample Circuit* x

4 3 2
 B
 20 PSI T-13A
 2500 psi
 FC10-2
 Cylinder Ret. Cylinder Ext.
 17 1/2 1800 psi
 P1 P2
 1 1/4" SAE RT2
 P1 P2
 1 1/4" SAE RT2
 TR1
 LVL
 A
 4 3 2 1
 Model Layout1 + PAPER MODEL

ITEM ID	QTY	MODEL CODE	DESCRIPTION
1	3	02H-OP-P30A3AE	PRESSURE GAUGE, 0-5000 PSI
2	1	RP1700	PUMP MOTOR ASSEMBLY
3	1	PZ1-20	MOUSE
4	1	P28-100	SUCKER CONTAINER
5	2	AA80B22AN	DIRECT ACTING PRESSURE RELIEF VALVE
6	1	CV242AN	SHOCK VALVE
7	1	AW26AN/REV230NH4	DIRECTION CONTROL VALVE
8	1	30A6RS08P0202	FILTER
9	1	GD0-0-0-DM	NEEDLE VALVE
10	1	LSB7	PLUG & TEMPERATURE SWITCH
11	1	BR20	FILLER/BREATHER
12	1	R00B12021	BLACK MATING CONNECTOR

ITEM ID	PORT TYPE	DESCRIPTION	PORT SIZE
BR, C, LVL, D	SAE O-RING	#8 SAE	#8 SAE
MC, MP, HR	SAE O-RING	#1 SAE	#1 SAE
P1, P2, PRL, T	SAE O-RING	#8 SAE	#8 SAE
TR1	SAE O-RING	#10 SAE	#10 SAE

NET NAME	NET LIST	NET PRESSURE (PSI)
NET-1	MC, S-2, C	3000
NET-2	P1, L, SA6	2500
NET-3	P2, P1, P1, MP, SA-1	2500
NET-4	HR, S-2, R, SB-1	2000
NET-6	S-1, S-B	2500
NET-7	S-1, SB-2, S-A	4000

FUNCTION	S,SV1	S,SV2	HOSE ID	QUANTITY	DESCRIPTION
CYLINDER EXT.	○	○	3	1	HOSE
CYLINDER RET.	○	○			

NAME	DATE	COMPANY
VEST, INC.		

INSERT LIST
 DR GRID
 ANGLE
 PROJECTION
 SYMBOL HERE

NAME: CYLINDER CONTROL
 DATE: 11/11/2019
 USER: B
 PROJECT: HYDCAD2019001
 SHEET: 1 OF 1

- 51 Change Text Height
- 52 Rotate Property Text
- 53 Show/Hide Properties
- 54 Reassign Item ID
- 55 Reassign Hose ID
- 56 Recreate Balloons
- 57 Add New Display Format

51. Change Text Height

Change the text height of the displayed Item ID and other parameters of the selected symbols.

1. Click System > **Height** 
on the HyDraw® CAD ribbon menu.
The Select Symbols and connections prompt displays on the command window.
2. Select a single symbol or multiple symbols, and connections.
After completion of selection, press the **Enter** key.
The Specify items to update [Item ID/ Property Text/ Solenoid Text/ Hose ID/ All] < All> prompt displays.
3. Enter the items to be updated and press the **Enter** key.
4. Select Item ID/ property text/ solenoid text/ Hose ID/ All:
The Change text height to <value>: prompt displays.
5. Enter the text height value and press the **Enter** key.
The height of the text is changed.

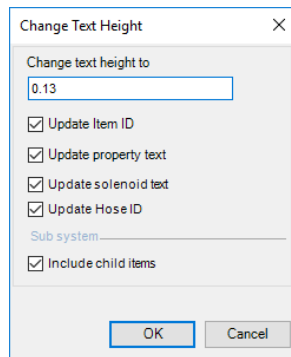

Change Text Height

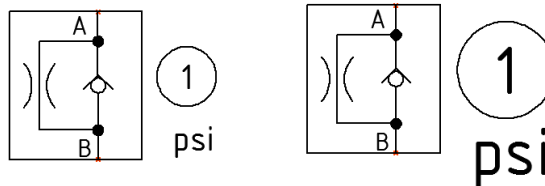

Text height changed (Before and After)

Note: Change Text Height dialog box will display when **Show options on Command Line** option is Unselected in HyDraw Options > Misc > Command Options.

52. Rotate Property Text

Rotate the displayed text of the selected symbols and connections.

1. Click System > **Rotate**  on the HyDraw® CAD ribbon menu.
The Select Symbols and Connections prompt displays.
2. Select a single symbol or multiple symbols and connections.
After completion of selection, press the **Enter** key.

The Rotate Property Text dialog box displays.

3. Select the property you want to rotate.

4. Click Rotate Left 

The Property Text rotates 90 degrees to its left.

5. Click Rotate Right 

The Property Text rotates 90 degrees to its right.

6. Click **OK**.

The property of the text is rotated.

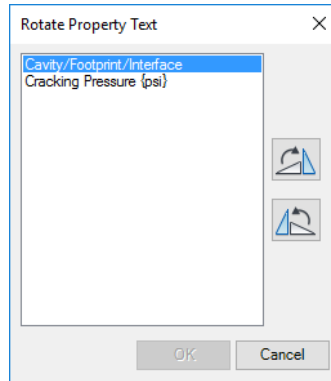

Rotate Property Text dialog box

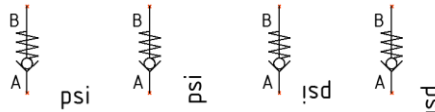

Property text rotated

53.Show/Hide Properties

The properties toggle between display or hide in the drawing.

1. Click System > **Properties** 
on the HyDraw® CAD ribbon menu.
The Select symbols and connections prompt displays.
2. Select a single or multiple symbols, external ports, connection lines
after completion of selection, press the **Enter** key.
The Show/Hide Properties dialog box displays.
3. Select the properties in the Sub-Systems & Components section, External Ports section and Connections section.
4. Click **OK** to apply and exit.

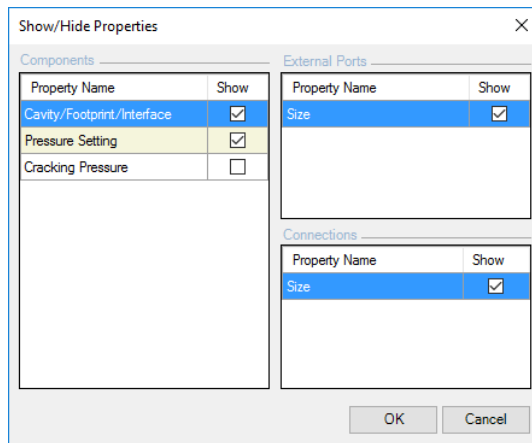

Show/Hide Property dialog box

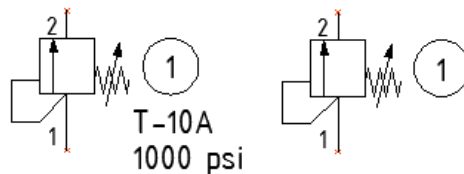

Hiding a Property

54.Reassign Item ID

Reassign the Item IDs and Assembly IDs of all symbols in the circuit after modification.

1. Click System >  on the HyDraw® CAD ribbon menu.
The Select Symbols prompt displays.
2. Select a single symbol or multiple symbols.
After completion of selection, press the **Enter** key.
The Reassign Item ID dialog box displays.
3. Enter the starting value of the **Item ID**.
4. Enter the **Assembly ID**.
Select the **Reassign Only Assembly ID** check box, if you want to reassign only assembly ID.
5. Select the **Include child items** checkbox to include sub-systems child items.
6. Choose the **Balloon type** for components, accessories, sub-systems and Hoses.
Select the checkbox, if you want to use the current balloon type.
7. Select the appropriate option for **Items included**.
 - Select the Sub-Systems & Components checkbox to include all sub-systems and components.
 - Select the Component accessories checkbox to include all component accessories.
 - Select the System accessories checkbox to include all system accessories.
 - Deselect the Hoses checkbox to exclude hoses.
8. Click **OK**.
9. For ISO 1219 Scheme, enter the Installation Code, Circuit Number and Medium Code.

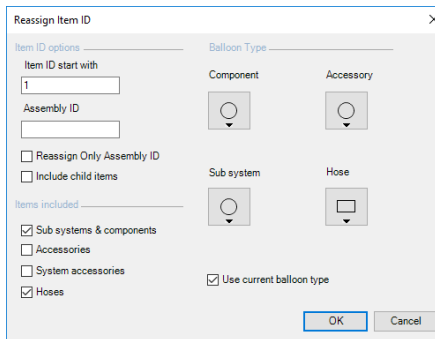

Reassign Item ID

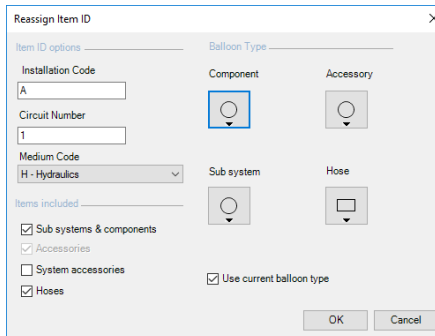

Reassign Item ID – ISO 1219 Scheme

55.Reassign Hose ID

Reassign the Hose IDs of all symbols in the circuit after modification.

1. Click System >  on the HyDraw® CAD ribbon menu.

The Select Symbols prompt displays.

2. Select a single symbol or multiple symbols. Only hoses symbols will be included.
After completion of selection, press the **Enter** key.

The Reassign Hose ID dialog box displays.

3. Enter the starting value of the **Hose ID**.

4. Enter the **Prefix**.

5. Choose the **Balloon type**.

Select the checkbox, if you want to use the current balloon type.

6. Click **OK**.

7. For ISO 1219 Scheme, enter the Installation Code, Circuit Number and Medium Code.

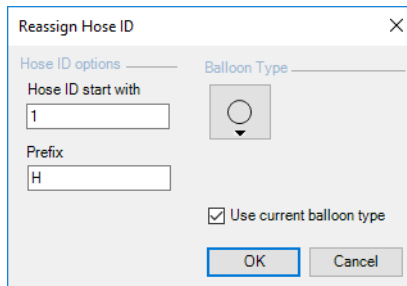

Reassign Hose ID

Hose ID options Balloon Type

Hose ID start with
1

Prefix
H

Use current balloon type

OK Cancel

Reassign Hose ID

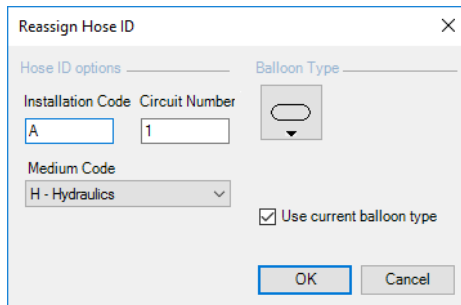

Reassign Hose ID

Hose ID options Balloon Type

Installation Code Circuit Number

A 1

Medium Code
H - Hydraulics

Use current balloon type

OK Cancel

Reassign Hose ID – ISO 1219 Scheme

56.Update Balloons

Update balloons of selected symbols or schematic.

This affects the type of balloons.

1. Click System > **Balloon** 
on the HyDraw® CAD ribbon menu.
The Select Symbols prompt displays.
2. Select a single symbol or multiple symbols.
After completion of selection, press the **Enter** key.

*The Specify Balloon type prompts,
[Circle/Ellipse/Rectangle/Rounded
rectangle/Hexagon/None/Use current balloon type]*

Update Balloon further prompts,

*Do you want to use different balloon style for sub-
systems [Yes No] <Yes>*

*The Specify Balloon type further prompts,
[Circle/Ellipse/Rectangle/Rounded
rectangle/Hexagon/None/Use current balloon type]*

Update Balloon further prompts,

Include child items [Yes No] <Yes>

*The Specify accessory balloon type prompts,
[Circle/Ellipse/Rectangle/Rounded
rectangle/Hexagon/None/Use current balloon type]*

*The selected balloon types are recreated for the
components, Accessories, Hoses, sub-systems and
sub-system child items.*

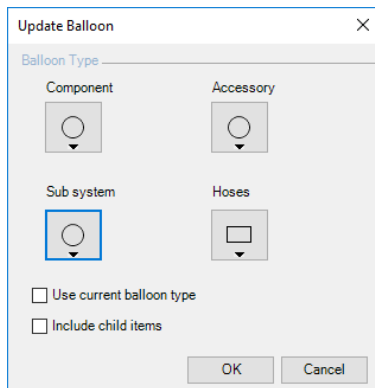

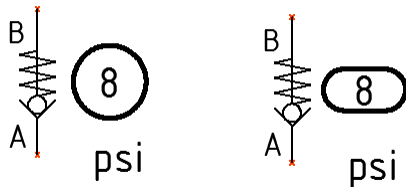

Update Balloon dialog



Changing Balloon from Circle to Rounded rectangle

57. Add New Display Format

Add a new display format of selected symbols and connections.

1. Click System > **Display Format**  on the HyDraw® CAD ribbon menu.
The Select Symbols and Connections prompt displays.
2. Select a single symbol or multiple symbols or connections.
After completion of selection, press the **Enter** key.
The Add New Display format dialog box displays.
3. Enter the **name** of the display format.
4. Click  on Property1 section to select property to display in the required format.
The Select Property dialog box displays.
5. Select property and click **OK**.
6. Enter **prefix** and **suffix** values to be displayed.
7. Select the **Display unit** check box to display units.
8. Repeat step 4 to select more than one and up to three properties to display in this display format.
9. Click **Add**.

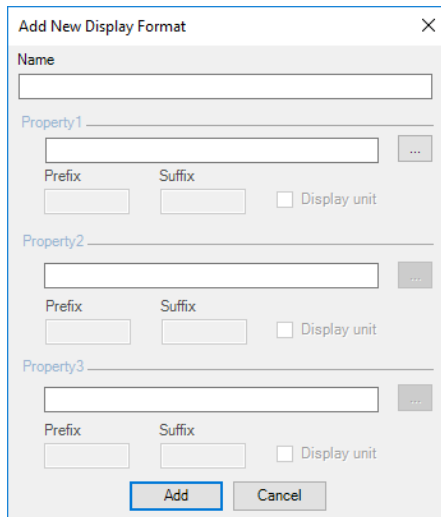

The "Add New Display Format" dialog box contains a "Name" field at the top. Below it are three sections for "Property1", "Property2", and "Property3". Each section includes a text input field, a "Prefix" field, a "Suffix" field, and a "Display unit" checkbox. To the right of each property name and text field is a small "..." button. At the bottom of the dialog are "Add" and "Cancel" buttons.

Add New Display Format dialog box

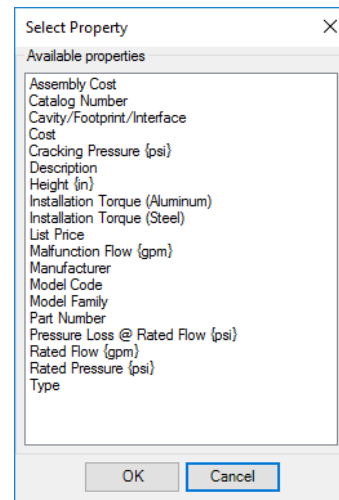

The "Select Property" dialog box features a list of "Available properties" including: Assembly Cost, Catalog Number, Cavity/Footprint/Interface Cost, Cracking Pressure (psi), Description, Height (in), Installation Torque (Aluminum), Installation Torque (Steel), List Price, Malfunction Flow (gpm), Manufacturer, Model Code, Model Family, Part Number, Pressure Loss @ Rated Flow (psi), Rated Flow (gpm), Rated Pressure (psi), and Type. At the bottom are "OK" and "Cancel" buttons.

Select Property

Lists

HyDraw CAD 2019 Sample Circuit.dwg

Height Rotate
Property Display Format
Design Notes
Balloon Item
Parts Ports Hose
Actuation Net
Docs CAD Files
MDTools
Convert to HyDraw
Update Drawing
Schematic Check
Insert Title Block
Edit Title Block
Unit Converter

Property Text
Show/Hide
ID
Lists
Collate
Export
Convert

Start Sample Circuit* x

- 58 Create and Insert Parts List
- 59 Create and Insert Ports List
- 60 Create and Insert Hoses List
- 61 Create Solenoid Actuation Chart
- 62 Create and Insert Net List
- 63 Create Design Notes List

ITEM ID	QTY	MODEL CODE	DESCRIPTION
1	3	03N-CP-36A5AE	PRESSURE GAUGE, 0-5000
2	1	RP-700	PUMP MOTOR ASSEMBLY
3	1	FL-20	HOSE
4	1	PP-100	SUCTION STRAINER
5	2	AR00022N	DIRECT ACTING PRESSURE RELIEF VALVE
6	1	C0010AN	SHOCK VALVE
7	1	AWEN-AN-REV130NRK4	DIRECTION CONTROL VAL
8	1	55AG-R556EPR020	FILTER
9	1	CD0-0-0-0M	NEEDLE VALVE
10	1	LSW7	FLIGHT & TEMPERATURE SWITCH
11	1	BR10	FILLER/BREATHER
12	1	RR0-0-TR02	BLACK HAIRING CONNECT

ITEM ID	PORT TYPE	DESCRIPTION	PORT SIZE
BR, C, LVL, R	SAE O-RING	#6 SAE	#6 SAE
MC, MP, HR	SAE O-RING	#6 SAE	#6 SAE
P1, P2, PPR1, T	SAE O-RING	#8 SAE	#8 SAE
TR1	SAE O-RING	#10 SAE	#10 SAE

NET NAME	NET LIST	NET PRESSURE (PSI)
NET-1	MC, 9-2, C	3000
NET-2	P, T, L, SA-2	2500
NET-3	P, P, P1, L, MP, SA-1	3000
NET-4	HR, 4-2, R, SB-1	2000
NET-6	R-1, 7-8	2500
NET-7	S-1, SB-2, 7-4	4000

FUNCTION	S.O.V1	S.O.V2	MODE ID	QUANTITY	DESCRIPTION
CYLINDER EXT.	○	○	3	1	HOSE
CYLINDER RET.	○	○			

INSERT 1ST DR. 3RD ANGLE PROJECTION SYMBOL HERE	NAME	DATE	COMPANY
DR. 3RD ANGLE PROJECTION SYMBOL HERE THE USER SHOULD SPECIFY IN THE COMMENTS FIELD THE PROJECTION TYPE TO BE USED IN THE DRAWING. THE USER SHOULD SPECIFY IN THE COMMENTS FIELD THE PROJECTION TYPE TO BE USED IN THE DRAWING. THE USER SHOULD SPECIFY IN THE COMMENTS FIELD THE PROJECTION TYPE TO BE USED IN THE DRAWING.	HYDRA		VEST, INC.

DATE	BY
DATE	BY

CYLINDER CONTROL

DATE: HYDCA02010001 1

DRAWN BY: DATE: 1 OF 1

58. Create and Insert Parts List

Create a list of components, envelope, sub-systems and accessories for a schematic.

1. Insert Parts List

1. Click System > **Parts List**  on the HyDraw® CAD ribbon menu.
The Select Symbols prompt displays.
2. Select a single or multiple symbol.
After completion of the selection, press the **Enter** key.
The Create Parts List dialog box displays.
3. Select the items to be included by clicking the required checkboxes,

Sub-Systems & Components:

Include all components & sub-systems in the Parts list.

Component accessories:

Include all component accessories in the Parts list.

System accessories:

Include all system accessories in the Parts list.

Group identical items:

Group all the identical items in the Parts list.

Include child items:

Include all the sub-system child items in the parts list.

Unselect the **Hoses** option to exclude hoses from the selection.

Group identical items work only for 1A, 1B, 2A, 2B..., 1,1,2, 2,..., 1.1,1.2,2.1,2.2..., and 1-1,1-2,2-1,2-2... numbering scheme.

4. Select the required **format**.

The default format is applied, if nothing is selected.

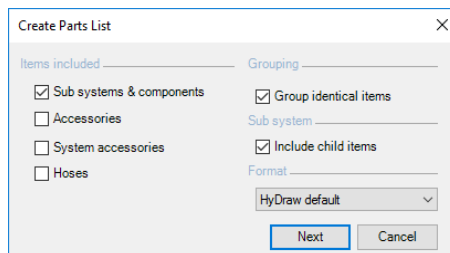

The dialog box 'Create Parts List' contains the following options:

- Items included: Sub systems & components, Accessories, System accessories, Hoses
- Grouping: Group identical items
- Sub system: Include child items
- Format: HyDraw default (dropdown menu)
- Buttons: Next, Cancel

Create Parts List dialog box

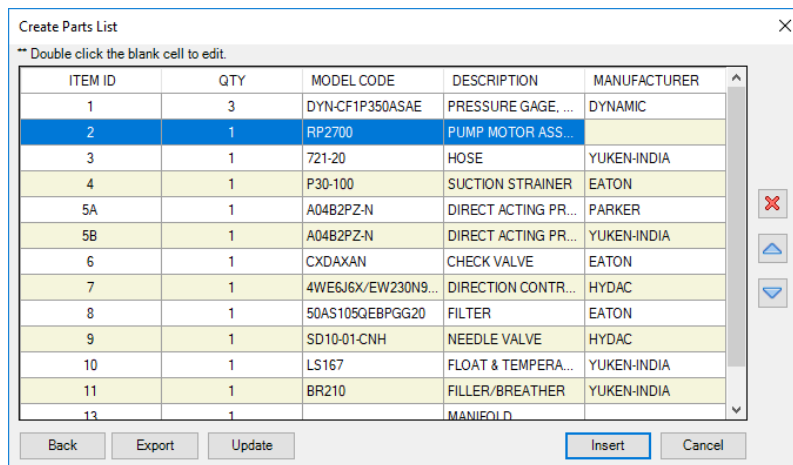

The dialog box 'Create Parts List' displays a table with the following data:



ITEM ID	QTY	MODEL CODE	DESCRIPTION	MANUFACTURER
1	3	DYN-CF1P350ASAE	PRESSURE GAGE, ...	DYNAMIC
2	1	RP2700	PUMP MOTOR ASS...	
3	1	721-20	HOSE	YUKEN-INDIA
4	1	P30-100	SUCTION STRAINER	EATON
5A	1	A04B2PZ-N	DIRECT ACTING PR...	PARKER
5B	1	A04B2PZ-N	DIRECT ACTING PR...	YUKEN-INDIA
6	1	CXDAXAN	CHECK VALVE	EATON
7	1	4WE6J6X/EW230N9...	DIRECTION CONTR...	HYDAC
8	1	50AS105QEBPGG20	FILTER	EATON
9	1	SD10-01-CNH	NEEDLE VALVE	HYDAC
10	1	LS167	FLOAT & TEMPERA...	YUKEN-INDIA
11	1	BR210	FILLER/BREATHER	YUKEN-INDIA
13	1		MANIFOLD	

Buttons: Back, Export, Update, Insert, Cancel

Create Parts List dialog box

5. Click **Next**

The Create Parts List dialog box displays the details of the Parts properties.

6. Click  or  to move the selected item row up or down, respectively.

7. Click  to delete the selected item from the list.

8. Double Click on Blank Cell to Edit Parts List.

Add missing property values of Components in Parts List.

9. Click **Update** after Editing Parts List.

10. Click **Yes**.

Updates values in Model Data of the Component in Parts List and HyDraw Property Manager.

11. Click **Insert to Drawing** to insert the Parts list as a separate list in the drawing.

12. Select an area to create Parts List.

13. Specify the first corner.

The Specify opposite corner: prompt displays.

14. Specify the opposite corner.

The Parts list is inserted into the drawing in a tabular form.

15. To save the Parts list as an Excel sheet, click **Export to Excel**.

The Parts List is saved in the Excel format.

Note:

- Parts List groups the components based on grouped Item ID and Model Code.
- If Part List does not contain Model Code, the components are grouped based on the identical properties.

ITEM ID	QTY	MODEL CODE	DESCRIPTION	MANUFACTURER
1	3	DYN-CF P 350 ASAE	PRESSURE GAGE, 0-5000 PSI	DYNAMIC
2	1	RP2700	PUMP MOTOR ASSEMBLY	CUSTOM
3	1	721-20	HOSE	YUKEN-INDIA
4	1	P30-100	SUCTION STRAINER	EATON
5	2	A04 B2PZ-N	DIRECT ACTING PRESSURE RELIEF VALVE	PARKER
6	1	CXD AXAN	CHECK VALVE	EATON
7	1	4WE6 J6X/EW230N9K4	DIRECTION CONTROL VALVE	HYDAC
8	1	50 AS105 OEBP GG20	FILTER	EATON
9	1	SD10-01-CNH	NEEDLE VALVE	HYDAC
10	1	LS 167	FLOAT & TEMPERATURE SWITCH	YUKEN-INDIA
11	1	BR210	FILLER/BREATHER	YUKEN-INDIA
12	1	R901017022	BLACK MATING CONNECTOR	BOSCH REXROTH

Parts List inserted in the drawing

2. Auto Update Parts List

1. Insert Parts List in the drawing.
2. Select a symbol and update Model Data value from HyDraw Property Manager.

Update notification  displays for the Model in the existing Parts List with the modified cell value in Red color.

3. Select and right-click the Part List table in the drawing.

Context menu displays.

4. Select Update Parts List.

Existing Parts List displays the updated values.

ITEM ID	QTY	MODEL CODE	DESCRIPTION	MANUFACTURER
1	1		MANIFOLD	
3	3	DYN-CF1P350ASAE	PRESSURE GAGE, 0-5000 PSI	DYNAMIC
4	1	RP2700	PUMP MOTOR ASSEMBLY	CUSTOM
6	1	P30-100	SUCTION STRAINER	EATON
7	1	A04B2PZ-N1	DIRECT ACTING PRESSURE RELIEF VALVE	PARKER
8	1	CXDAXAN	CHECK VALVE	EATON
9	1	4WE6J6X/EW230N9K4	DIRECTION CONTROL VALVE	HYDAC
 10	1	A04B2PZ-N	DIRECT ACTING PRESSURE RELIEF VALVE	YUKEN-INDIA
11	1	50AS105QEBPGG20	FILTER	EATON
12	1	SD10-01-CN4	NEEDLE VALVE	HYDAC
13	1	LS167	FLOAT & TEMPERATURE SWITCH	YUKEN-INDIA
14	1	BR210	FILLER/BREATHER	YUKEN-INDIA
15	1	R901017022	BLACK MATING CONNECTOR	BOSCH REXROTH

Parts List inserted in the drawing

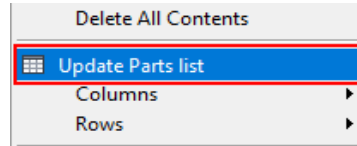



Update Parts List – Context Menu

ITEM ID	QTY	MODEL CODE	DESCRIPTION	MANUFACTURER
1	1		MANIFOLD	
3	3	DYN-CF1P350ASAE	PRESSURE GAGE, 0-5000 PSI	DYNAMIC
4	1	RP2700	PUMP MOTOR ASSEMBLY	CUSTOM
6	1	P30-100	SUCTION STRAINER	EATON
7	1	A04B2PZ-N1	DIRECT ACTING PRESSURE RELIEF VALVE	PARKER
8	1	CXDAXAN	CHECK VALVE	EATON
9	1	4WE6J6X/EW230N9K4	DIRECTION CONTROL VALVE	HYDAC
10	1	A04B2PZ-N121	DIRECT ACTING PRESSURE RELIEF VALVE	YUKEN-INDIA

Updated Parts List in Drawing

3. Customize Parts List Format

1. Click **Circuit > Options...** on the HyDraw® CAD ribbon menu.
2. Click the **Lists & Charts** tab and select **Parts List**.
The Parts List formatting box displays inside the tab.
3. To rename a selected format, type the new name in the text box and click .
4. To add a new format, type the new name in the text box and click .
5. To delete a selected format, click  below the textbox.
*The **Configure Columns** section enables to edit Display Name, Alignment, and Width of the columns.*
6. Click **Add**.
The Select Parts List Columns dialog box displays.
7. Select the required Model properties or Design requirements checkbox.
8. Click **Browse** and select the Excel template.
9. Set the Start Column and the Start Row of the Parts list to be inserted into the Excel template.
10. Click **OK**.

The properties of the selected items are displayed in the Parts List formatting box in the Configure columns section.

Same properties are displayed in the tabular form Parts list, when creating Parts list in the drawing.

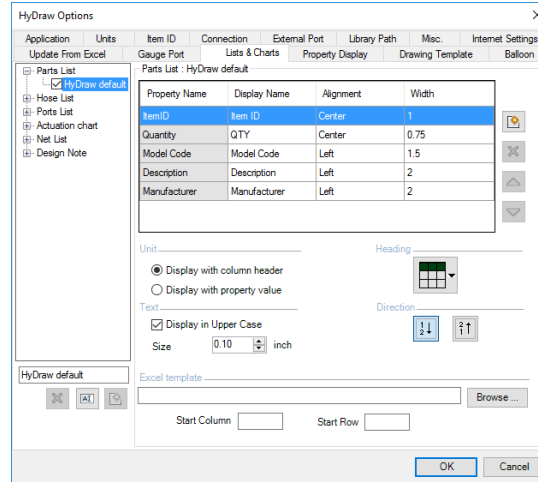

Lists & Chart Tab: Parts List

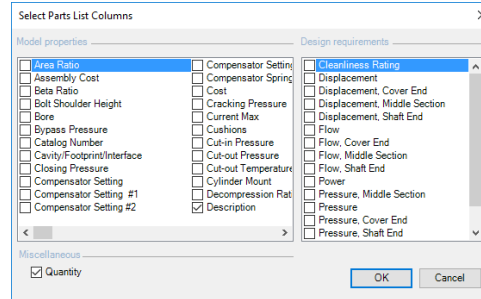

Select Parts List Columns dialog box

59. Create and Insert Ports List

Create a list of external ports used in the circuit. You can insert this list in the drawing. The tabular list exhibit details about the external ports.

1. Insert Ports List

1. Click System > **Ports List**  on the HyDraw® CAD ribbon menu.

The Select Ports prompt displays.

2. Select a single or multiple port. After the completion of selection, press the **Enter** key.

The Create Ports List dialog box displays.

3. Select the **Group identical items** checkbox to group all identical items in the Ports list.

- i. Select the required **format**.

If no format is selected, then the default format is applied.

4. Click **Next** to display the Create Ports List dialog box.

The Create Ports List dialog box displays the details of the port properties.

5. Click  or  to move the selected item row up or down, respectively.

6. Click  to delete the selected port from the list.

7. Click **Insert to Drawing** to insert the Ports list as a separate list in the drawing.

8. Select an area to create the Ports List.

Specify first corner: prompt displays.

9. Specify the first corner.

The Specify opposite corner: prompt displays.

10. Specify the opposite corner.

The Ports list is inserted into the drawing in a tabular form.

11. To save the Ports list as an Excel sheet, click **Export to Excel**.

The Ports List is saved in the Excel format.

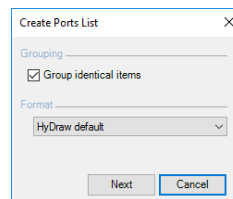

Create Ports List dialog box

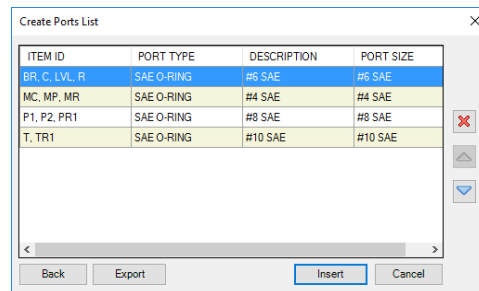

Create Ports List

ITEM ID	PORT TYPE	DESCRIPTION	PORT SIZE
BR, C, LVL, R	SAE O-RING	#6 SAE	#6 SAE
MC, MP, MR	SAE O-RING	#4 SAE	#4 SAE
P1, P2, PR1, T	SAE O-RING	#8 SAE	#8 SAE
TR1	SAE O-RING	#10 SAE	#10 SAE

Ports List in the drawing

2. Customize Ports List Format

1. Click Circuit > **Options...** on the HyDraw® CAD ribbon menu.

2. Click the **Lists & Charts** tab and select **Ports List**.

The Ports list formatting box displays inside the tab.

3. To rename a selected format, type the new name in the textbox and click .

4. To add a new format, type the new name in the textbox and click  below the text box.

5. To delete a selected format, click .

*The **Configure Columns** section enables editing of the Display Name, Alignment, and Width of the columns.*

6. Click .

The Select Ports List columns dialog box displays.

7. Select the required properties.

8. Click **OK**.

The properties of the selected item are displayed in the Ports List formatting box in the Configure columns section.

Same properties are displayed in the tabular form Ports list, when creating the Ports list in the drawing.

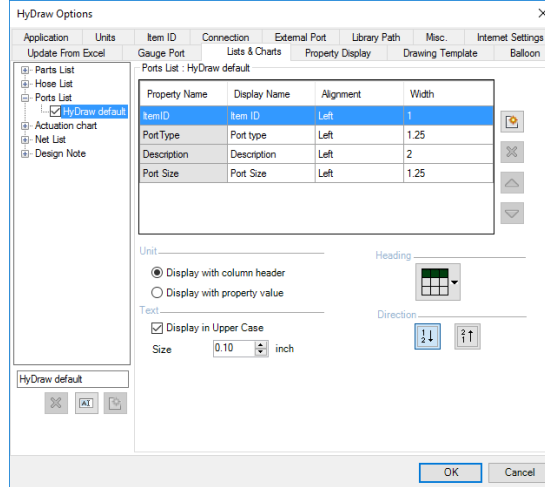

Ports List tab

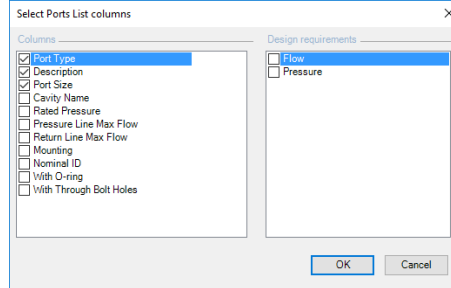





Select Ports List columns

60. Create and Insert Hose List

Create a list of hoses used in the circuit. You can insert this list in the drawing. The tabular list exhibit details about the hoses.

1. Insert Hose List

1. Click System > **Hose List**  on the HyDraw® CAD ribbon menu.
The Select Hoses prompt displays.
2. Select a single or multiple hose. After the completion of selection, press the **Enter** key.
The Create Hoses List dialog box displays.
3. Select the **Group identical items** checkbox to group all identical items in the Hose list.
Group identical items works only for the given *numbering* scheme in Option.
4. Select the required **format**. If no format is selected, then the default format is applied.
5. Click **Next** to display the Create Hose List dialog box.
The Create Hose List dialog box displays the details of the hoses properties.
6. Click  or  to move the selected item row up or down, respectively.
7. Click  to delete the selected hose from the list.
8. Click **Insert to Drawing** to insert the hose list as a separate list in the drawing.
9. Select an area to create the Hose List.
Specify first corner: prompt displays.
10. Specify the first corner.
The Specify opposite corner: prompt displays.
11. Specify the opposite corner.
The Hose list is inserted into the drawing in a tabular form.
12. To save the Hose list as an Excel sheet, click **Export to Excel**.
The Hose List is saved in the Excel format.

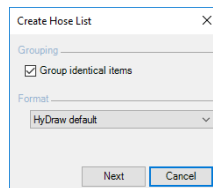

Create Hose List dialog box

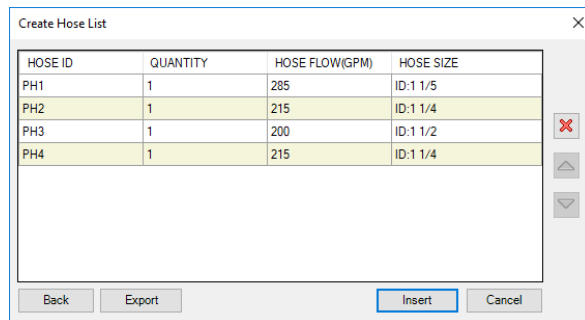





Create Hose List

HOSE NO.	QUANTITY	HOSE FLOW	HOSE SIZE
PH1	1	285	ID:1 1/5
PH2	1	215	ID:1 1/4
PH3	1	200	ID:1 1/2
PH4	1	215	ID:1 1/4

Hoses List in the drawing

2. Customize Hose List Format

1. Click Circuit > **Options...** on the HyDraw® CAD ribbon menu.
2. Click the **Lists & Charts** tab and select **Hose List**.
The Hose list formatting box displays inside the tab.
3. To rename a selected format, type the new name in the textbox and click .
4. To add a new format, type the new name in the textbox and click  below the text box.
5. To delete a selected format, click .
6. Click .
7. Select the required properties.
8. Click **OK**.

The properties of the selected item are displayed in the Hose List formatting box in the Configure columns section.

Same properties are displayed in the tabular form Hose list, when creating the Hose list in the drawing.

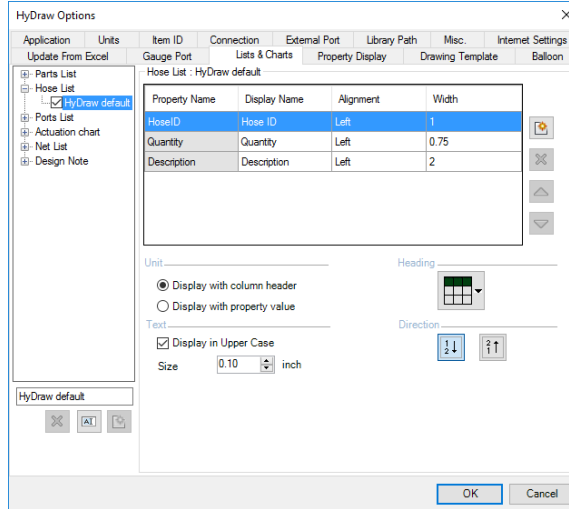



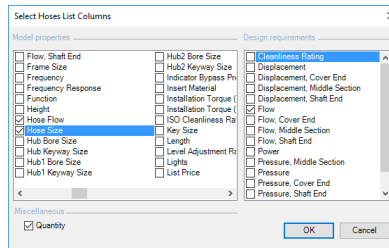

List & Chart Tab - Hose List



Select Hose List columns

61. Create Solenoid Actuation Chart

Insert the Solenoid Actuation chart in the drawing.

1. Click Circuit > **Actuation**  on the HyDraw® CAD ribbon menu.
The Select Symbols prompt displays.
2. Select a single or multiple symbol. After the completion of selection, press the **Enter** key.
The Use Item ID [Yes No] <Yes> prompt displays.
3. Press **Enter**.
The Solenoid Actuation Chart displays Function, Item ID-Solenoid ID, if applicable.
4. Click the **Update**  button to update the function name.
The Update Function dialog box displays.
 - Select the function to update.
 - Rename the function.
 - Click **Update**.
 - Click **OK** to display the changes in the Solenoid Actuation chart.
5. Click  or  to move the selected item one row up or one row down, respectively.
6. Click  to delete the selected function from the list.
7. Click **Export to Excel** to save the Solenoid Actuation chart as an Excel file (.xls or .xlsx).
8. Click **Insert to Drawing** to insert the Solenoid Actuation chart into the drawing.
You can customize the Actuation List Format from HyDraw Option.

Note:

Solenoid IDs must be unique to create Solenoid Actuation Chart.

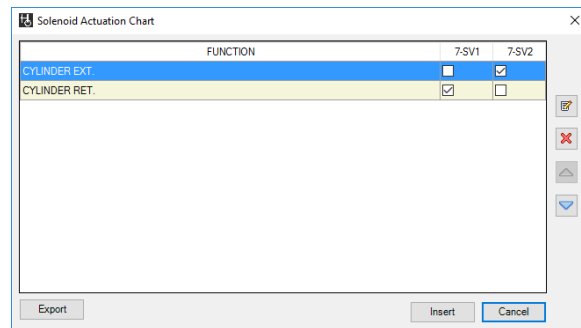

Solenoid Actuation Chart – Grid View

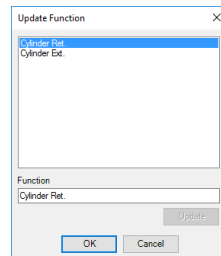



Update Function







FUNCTION	7-SV1	7-SV2
CYLINDER EXT.	<input type="radio"/>	<input checked="" type="radio"/>
CYLINDER RET.	<input checked="" type="radio"/>	<input type="radio"/>

Solenoid Actuation Chart

62. Create and Insert Net List

Create a list of networks (Net List) of components and external ports in the circuit.
You can insert the Net list in the drawing. The tabular list exhibit details about the networks.

1. Click System > **Net List**  on the HyDraw® CAD ribbon menu.
The Select manifold prompt displays.
2. Select the envelope line. After completion of selection, press the **Enter** key.
The Create Net List box displays net name with the corresponding net items and status.
3. Enter the Net Pressure for the whole net.
This updates the pressure of all the symbols in the net.
The Status column shows the accounted nets with  and amended nets with  indicating that the nets are amended and require recreation.
By selecting a net on the Status column, the respective net is shown as hidden in the drawing.
(In case of hidden connection lines at low zoom level, the hidden preview may not be visible. If the connection is not correct, red dots appear along the connection points.)
4. Click **Clear Error Flags** to remove the error flags from the drawing.
5. Click **Recreate** to return to create the Net list.
6. Click **Export** to save the Net list as an Excel file (.xls or .xlsx).
7. Click **Insert** to insert the Net list in the drawing.
8. Select an area to create the Net list.
The Specify first corner prompt displays.
9. Specify the first corner.
The Specify opposite corner: prompt displays.
10. Specify the opposite corner.
The Net list is inserted into the drawing.
11. Click **OK** to exit or Click **Cancel** to cancel the Net list creation.

NET NAME	NET LIST	NET PRESSURE (PSI)	STATUS
NET-1	MC, C, 9-2	3000	
NET-2	T, 5A-2, 7-T	2500	
NET-3	P2, P1, MP, 5A-1, 7-P	3500	
NET-4	R, MR, 5B-1, 6-2	2000	
NET-6	9-1, 7-B	2500	
NET-7	5B-2, 6-1, 7-A	4000	

Buttons: Recreate, Export, Clear Error Flags, Insert, OK, Cancel

Create Net List

NET NAME	NET LIST	NET PRESSURE (PSI)
NET-1	MC, 9-2, C	3000
NET-2	7-T, T, 5A-2	2500
NET-3	7-P, P2, P1, MP, 5A-1	3500
NET-4	MR, 6-2, R, 5B-1	2000
NET-6	9-1, 7-B	2500
NET-7	6-1, 5B-2, 7-A	4000

Net List

Note:

- The individual symbols of Slip-Cartridge valve cover and Insert are combined with “&” and accepted as a single entity, when creating the Net list.
- Orifice disc should be ignored, when creating the Net List.

CAUTION!

- Do not create more than one connection to the connection points. This may result in an incorrect Net list.
- If **OK** is not pressed after net renaming, the corrections will be lost on recreation, with default net naming style.

Note:



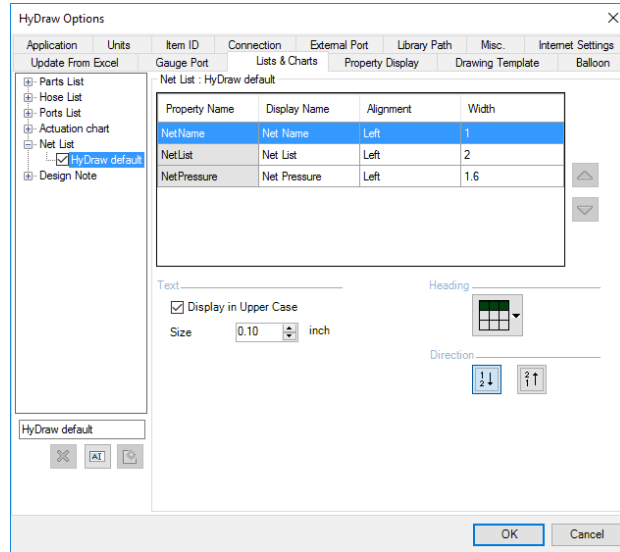

You can customize the Net List Format from HyDraw Option.



HyDraw Option-Net List

63. Create Design Note List

Create Design notes list in the circuit and insert it in the drawing.

1. Click System > **Notes**  on the HyDraw® CAD ribbon menu.
The Select Symbols and Connections prompt displays.
2. Select symbols and connections.
After completion of selection, press the **Enter** key.
The Create Design Note List box displays.
3. Click  or  to move the selected item one row up or one row down, respectively.
4. Click  to delete the selected function from the list.
5. Click **Export** to save the Design Note list as an Excel file (.xls or .xlsx).
6. Click **Insert** to insert the Design Note list in the drawing.
7. Select an area to create the Design Note list.
The Specify first corner prompt displays.
8. Specify the first corner.
The Specify opposite corner: prompt displays.
9. Specify the opposite corner.
The Design Notes list is inserted into the drawing.
10. Click **OK** to exit or Click **Cancel** to cancel the Design Note list creation.
You can customize the Design Note List Format from HyDraw Option.

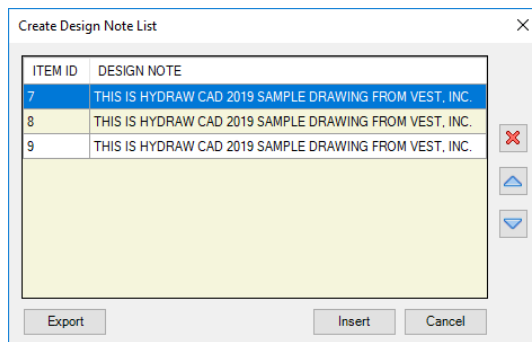

Create Design Notes List

ITEM ID	DESIGN NOTE
7	THIS IS HYDRAW CAD 2019 SAMPLE DRAWING FROM VEST, INC.
8	THIS IS HYDRAW CAD 2019 SAMPLE DRAWING FROM VEST, INC.
9	THIS IS HYDRAW CAD 2019 SAMPLE DRAWING FROM VEST, INC.

Design Notes List

Collate Files

HyDraw CAD 2019 Sample Circuit.dwg

Collate Export Convert Check Title Block Edit Unit Converter

64 Collate Documents
65 Collate CAD Files

The diagram shows a hydraulic circuit with various components including pumps, valves, cylinders, and hoses. The circuit is divided into sections labeled A, B, and C. The parts list table on the right provides details for each component.

ITEM ID	QTY	MODEL CODE	DESCRIPTION	MANUFAC
1	3	DYN-OP-P30A3AE	PRESSURE GAUGE, 0-5000 PSI	DYNAMIC
2	1	MP-700	PUMP MOTOR ASSEMBLY	CUCTION
3	1	Z1-10	HOSE	YUEN-INDIA
4	1	P28-100	SUCTION CONTAINER	EA-TON
5	2	AA80B22AN	DIRECT ACTING PRESSURE RELIEF VALVE	PARSON
6	1	CV24-2AN	SHOCK VALVE	EA-TON
7	1	AW28AN/REV2/20NH4	DIRECTION CONTROL VALVE	HYDAC
8	1	50AG3050P0202	FILTER	EA-TON
9	1	LD 0-1-1-0M	NEEDLE VALVE	HYDAC
10	1	LSR7	FLOAT & TEMPERATURE SWITCH	YUEN-INDIA
11	1	BR210	FILLER/BREATHER	YUEN-INDIA
12	1	RR617021	BLACK MATING CONNECTOR	BOCHH REAYROTH

ITEM ID	PORT TYPE	DESCRIPTION	PORT SIZE
DR, C, LVL, D	SAE O-RING	#6 SAE	#6 SAE
MC, MP, HR	SAE O-RING	#1 SAE	#1 SAE
P1, P2, PRL, T	SAE O-RING	#8 SAE	#8 SAE
TR1	SAE O-RING	#10 SAE	#10 SAE

NET NAME	NET LIST	NET PRESSURE (PSI)
NET-1	MC, S-2, C	3000
NET-2	T-1, L, SA-1	2500
NET-3	P28, P1, P1, MP, SA-1	2500
NET-4	HR, S-2, R, SB-1	2000
NET-6	S-1, S-2	2500
NET-7	S-1, SB-2, S-4	4000

FUNCTION	S,SV1	S,SV2	HOSE ID	QUANTITY	DESCRIPTION
CYLINDER EXT.	○	○	3	1	HOSE
CYLINDER RET.	○	○			

NAME	DATE	COMPANY
VEST, INC.		

INSERT LIST
DR: 0RD
ANGLE
PROJECTION
SYMBOL: HERE

NAME: CYLINDER CONTROL
DATE: 11/11/2019
BY: B
SCALE: 1:1

64. Collate Documents

Save documents linked to components, external ports, sub-systems, component accessories, and system accessories in the user-specified location.

1. Click System > **Collate Documents**  from the Collate option on the HyDraw® CAD ribbon menu.

The Select Symbols prompt displays. The Collate Documents dialog box displays.

2. Select a single symbol or multiple symbols and then press the **Enter** key.

The Specify items included [Sub-Systems & Components/External Ports/Accessories/Include all/More options] <Include All> prompt displays.

Sub-Systems & Components further prompts,

Include Child Items [Yes No] <Yes>.

More Options further Prompts,

Include Components [Yes No] <Yes>.

Include Component Accessories [Yes No] <Yes>.

Include System Accessories [Yes No] <Yes>.

3. Select the required option and press the **Enter** key.

The Collate Documents dialog box displays.

4. Select the documents to be collated.

5. Click OK.

The Browse for Folder dialog box displays.

6. Select the appropriate folder or click **Make New Folder** to create a new folder at the appropriate location for saving documents.

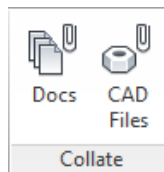

Collate Documents dialog box

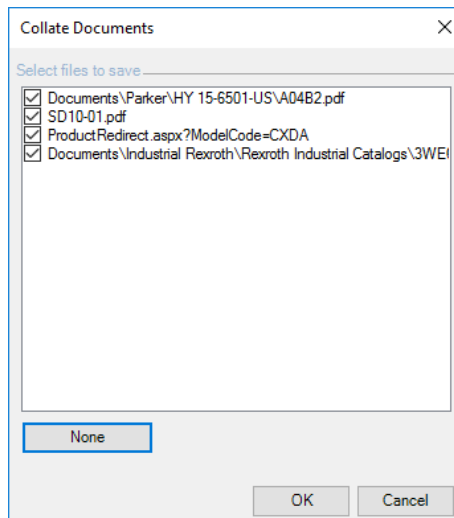

Collate Documents: save files

65. Collate CAD Files

Save the CAD files linked to the Components, External Ports, Sub-Systems, Component accessories, and system accessories in the user-specified location.

1. Click System > **Collate CAD Files**  from the Collate option on the HyDraw® CAD ribbon menu.

The Select Symbols prompt displays.

2. Select a single symbol or multiple symbols and press the **Enter** key.

The Specify items included [Components/External Ports/Accessories/Include all/More options] <Include All> prompt displays.

Sub-Systems & Components further prompts,

Include Child Items [Yes No] <Yes>.

More Options further Prompts,

Include Components [Yes No] <Yes>.

Include Component Accessories [Yes No] <Yes>.

Include System Accessories [Yes No] <Yes>.

3. Select the required option and press the **Enter** key.

The Collate CAD Files dialog box displays.

4. Select the **CAD files** to be collated.

5. Click **OK**.

The Browse for Folder dialog box displays.

6. Select the appropriate folder or click **Make New Folder** to create a new folder in the appropriate location for saving CAD files.

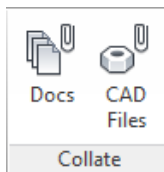

Collate CAD Files dialog box

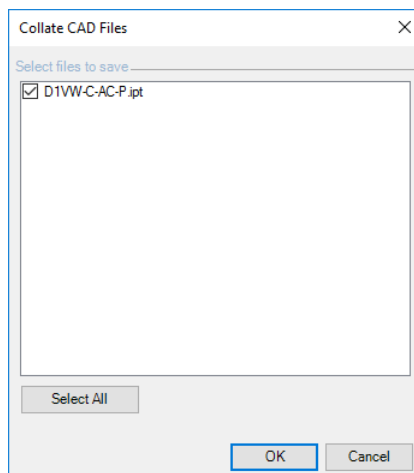

Collate CAD Files: Save Files

Calculator

HyDraw CAD 2019 Sample Circuit.dwg

66 Unit Converter

The image displays the HyDraw CAD 2019 software interface. The top menu bar includes options like Circuit, System, Services, Home, Insert, Annotate, Parametric, View, Manage, Output, and Help. Below the menu is a toolbar with various icons for editing and viewing. The main workspace shows a hydraulic circuit diagram with components like pumps, valves, and cylinders. A table on the right lists the components with their item IDs, quantities, model codes, descriptions, and manufacturers. Below the table are sections for port types, net lists, and functions.

ITEM ID	QTY	MODEL CODE	DESCRIPTION	MANUFACTURER
1	3	DYN-OP-P30A3AE	PRESSURE GAGE, 0-5000 PSI	DYNAMIC
2	1	RP1700	PUMP MOTOR ASSEMBLY	CUCTION
3	1	Z1-10	HOSE	YUEN-INDIA
4	1	P2B-10	SUCTION CONTAINER	EA-TON
5	2	AA80B22AN	DIRECT ACTING PRESSURE RELIEF VALVE	PAWEN
6	1	CD3A-1AN	SHOCK VALVE	EA-TON
7	1	AWEN3AN/REV230NH4	DIRECTION CONTROL VALVE	HYDOLC
8	1	50AG3050P0020	FILTER	EA-TON
9	1	GD0-0-0-0M	NEEDLE VALVE	HYDOLC
10	1	LSR7	FLOAT & TEMPERATURE SWITCH	YUEN-INDIA
11	1	BR210	FILLER/BREATHER	YUEN-INDIA
12	1	RR017021	BLACK MATING CONNECTOR	BOUCH REYNOLD

ITEM ID	PORT TYPE	DESCRIPTION	PORT SIZE
DR, C, LVL, D	SAE O-RING	#6 SAE	#6 SAE
MC, MP, HR	SAE O-RING	#4 SAE	#4 SAE
P1, P2, PRL, T	SAE O-RING	#6 SAE	#6 SAE
TR1	SAE O-RING	#10 SAE	#10 SAE

NET NAME	NET LIST	NET PRESSURE (PSI)
NET-1	MC, S-2, C	3000
NET-2	P-1, L, SAE1	2500
NET-3	P2, P1, P1, MP, SA-1	2500
NET-4	HR, S-1, R, SB-1	2000
NET-6	S-1, S-B	2500
NET-7	S-1, SB-2, S-A	4000

FUNCTION	S,SV1	S,SV2	HOSE ID	QUANTITY	DESCRIPTION
CYLINDER EXT.	○	○	3	1	HOSE
CYLINDER RET.	○	○			

NAME	DATE	COMPANY
VEST, INC.		

INSERT LIST
 DR: 0RD
 ANGLE
 PROJECTION
 SYMBOL HERE

NAME: CYLINDER CONTROL
 DATE: 11/11/2019
 USER: B
 DRAWING: HYDCAD2019001
 SHEET: 1 OF 1

66. Unit Converter

Convert value of any unit category from any unit to the other.

1. Click System > **Unit Converter** from the Calculator option on the HyDraw® CAD ribbon menu.

The Unit Converter dialog box displays.

2. Select a unit category.
3. Select the unit system in the **From** and **To** Units list box, per requirement.

4. Specify the unit value in the **From** text box.

*Converted unit value appears in the **To** text box in the desired unit system.*

7. Click  to copy the **To** value to the clipboard.



HyDraw Unit Converter

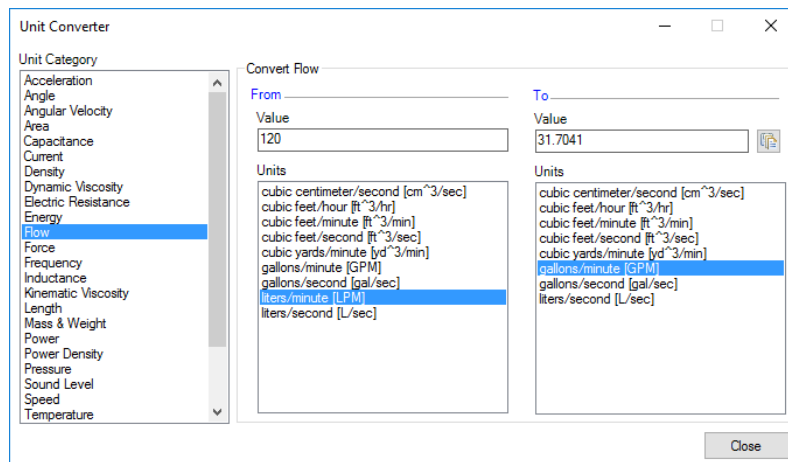

Unit Converter dialog box

MDTools Interface

HYDRAW EXPORT TO MDTOOLS

Manifold Properties
 Design Unit: Inch
 Material: Aluminum
 Manifold Pressure: 0

Components and External Ports
 Cavities: 5A, 5B, 6, 7, 9
 Ports: C, MC, MD

Cavity Information
 Port Information
 CAD Files

Mounting Holes
 None
 Threaded Bolt Hole
 Thru. Hole

Report Save Export

Model Layout1

HyDraw CAD 2019 Sample Circuit.dwg

67 Export to MDTools

ITEM ID	QTY	MODEL CODE	DESCRIPTION	MANUFACTURER
1	1	DPKCP-PR300-AC4K	PRESSURE GAUGE, 0-3000 PSI	HYDAC
2	1	RP200	PUMP MOTOR ASSEMBLY	EUCOTON
3	1	TEL-20	HOSE	
4	1	P30L-80	PLUG	HYDAC
5	2	AD-ABS-PL-N	PIPE	
6	1	CKD-KAN	CHECK VALVE	EATON
7	1	AV65-20/2V-230NKA	DIRECTION CONTROL VALVE	HYDAC
8	1	5043 BOSCH-PS200	FILTER	EATON
9	1	CDR-BL-L0W	NEEDLE VALVE	HYDAC
10	1	LS-7	FLOAT & TEMPERATURE SWITCH	FUSEN-INDIA
11	1	BRD-0	FILLET/BREAKTHRU	FUSEN-INDIA
12	1	RSW-TR02	BLACK HATING CONNECTOR	BOSCH-REXROTH

ITEM ID	PORT TYPE	DESCRIPTION	PORT QTY
BR, C, LVL, R	SAE O-RING	#6 SAE	#6 SAE
MC, MP, MR	SAE O-RING	#4 SAE	#4 SAE
PL, PL1, PR1, T	SAE O-RING	#0 SAE	#0 SAE
TR1	SAE O-RING	#0 SAE	#0 SAE

NET NAME	NET LIST	NET PRESSURE (PSI)
NET-1	MC, R-2, C	3000
NET-2	T, T, SA-2	2500
NET-3	T, P, P2, P1, MP, SA-1	3000
NET-4	MR, L-2, R, SB-1	2500
NET-5	PL-1, L-2	2500
NET-7	SA-1, SB-2, LA	1000

FUNCTION	T-SV1	T-SV2	HOSE ID	QUANTITY	DESCRIPTION
CYLINDER EXT.	<input type="radio"/>	<input checked="" type="radio"/>		3	1 HOSE
CYLINDER RET.	<input checked="" type="radio"/>	<input type="radio"/>			

INSERT LIST	CHKD	DATE	COMPANY
CR-3RD			VEST, INC.
ANGLE			
PROJECTION			
SYMBOL			
HYDRONIC			
FRONT			

67.Export to MDTools

Export a HyDraw® CAD created circuit as an XML, which can be readily opened in MDTools® for designing a manifold.

1. Click System > **MDTools** on the HyDraw CAD ribbon menu.

The Set Library Path dialog box displays.

2. Click the **Browse** button to search the Library Path.

The Browse for Folder dialog box displays.

3. Browse and select the folder with MDTools library.

4. Click **OK** to confirm the selection.

The Select Symbols and Connections prompt displays.

5. Select symbols and connections from the drawing.

6. After completion of selection, press the **Enter** key.

The Export to MDTools page loads.

The data and the default values entered into HyDraw® are automatically read from the drawing.

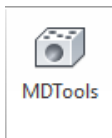

Export to MDTools

Note:

Once specified, you cannot change the MDTools library path.

Manifold Properties

Configure following settings,

- Material
- Manifold Pressure

Note:

By default, Design Unit comes per unit selection in the HyDraw Options.

Components and External Ports

The Cavities section displays Component ID, Port Name, Linked CAD Files, Cavity, Engraving and Preferred Faces of the component.

Configure following settings,

- Engraving
- Preferred Face

The Nets section displays Nets and Net Information, Net Type and Net Pressure.

Mounting Hole

Select the required type mounting hole option.

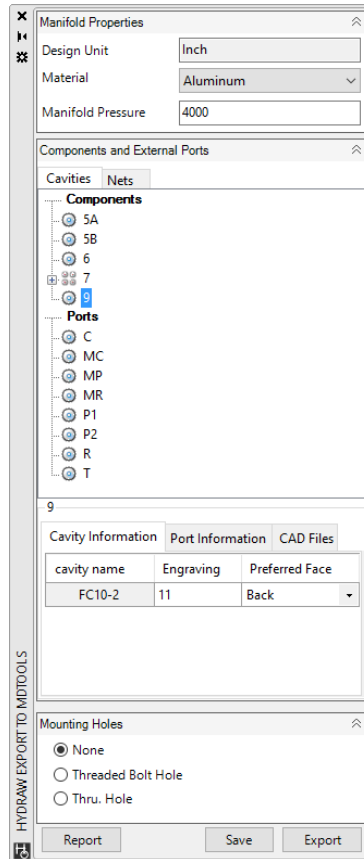

Export to MDTools

Report

Click Report > Schematic report dialog box displays.

The Schematic report contains all extracted data from HyDraw Schematic.

Export to MDTools report								
Report								
Components and Orifices								
Item ID	Cavity name	Port name	Flow	Type	Net Name	Engraving	CAD Files	Face Preference
5A	C10-2	Port-1	26	Pressure	NET-3	7A		Left
		Port-2	26	Tank	NET-2			
5B		Port-1	26	Pressure	NET-4	7B		Left
		Port-2	26	Pressure	NET-7			
6	T-13A	Port-1	10	Pressure		8		Front
		Port-2	10	Pressure	NET-4			
7	D03	B	6	Pressure	NET-6	9	D1VV-C-AC-P.ipt	Top
		P	6	Pressure	NET-3			
		T	8	Tank	NET-2			
		A	6	Pressure	NET-7			
9	FC10-2	Port-1	42	Pressure	NET-6	11		Right
		Port-2	42	Pressure	NET-1			
External Ports								
Port name	Cavity name	Type	Flow	Net Name	Engraving	CAD Files	Face Preference	
C	#6 SAE	Pressure	12	NET-1	C		Back	
MC	#4 SAE	Pilot	6	NET-1	MC	#4 SAE.ipt	Left	
MP	#4 SAE	Pressure	6	NET-3	MP		Right	
MR	#4 SAE	Pilot	6	NET-4	MR		Front	
P1	#8 SAE	Pressure	19	NET-3	P1		Front	
P2	#8 SAE	Pressure	19	NET-3	P2		Right	
R	#6 SAE	Pressure	12	NET-4	R		Left	
T	#8 SAE	Tank	19	NET-2	T		Front	
Net List								
Net Name	Net List							Net Pressure
NET-1	MC, C, 9-2							3000
NET-2	T, 5A-2, 7-T							2500
NET-3	P2, P1, MP, 5A-1, 7-P							3500
NET-4	R, MR, 5B-1, 6-2							2000
NET-6	9-1, 7-B							2500
NET-7	5B-2, 6-1, 7-A							4000

Schematic Reports

Export

Click Export > Save Input File dialog box displays.

Save the resulting XML file at the desired location.

Note:

- Information about CAD files, linked to components and accessories, is exported to MDTools, so that it automatically assembles the component models on the block.
- The individual symbols of Slip-in cartridge cover and insert are combined with “&” and accepted as a single entity in the HyDraw Export to MDTools.
- The individual symbols of Cartridge symbol and Orifice Disc are combined with “&” and accepted as a single entity in the HyDraw Export to MDTools.

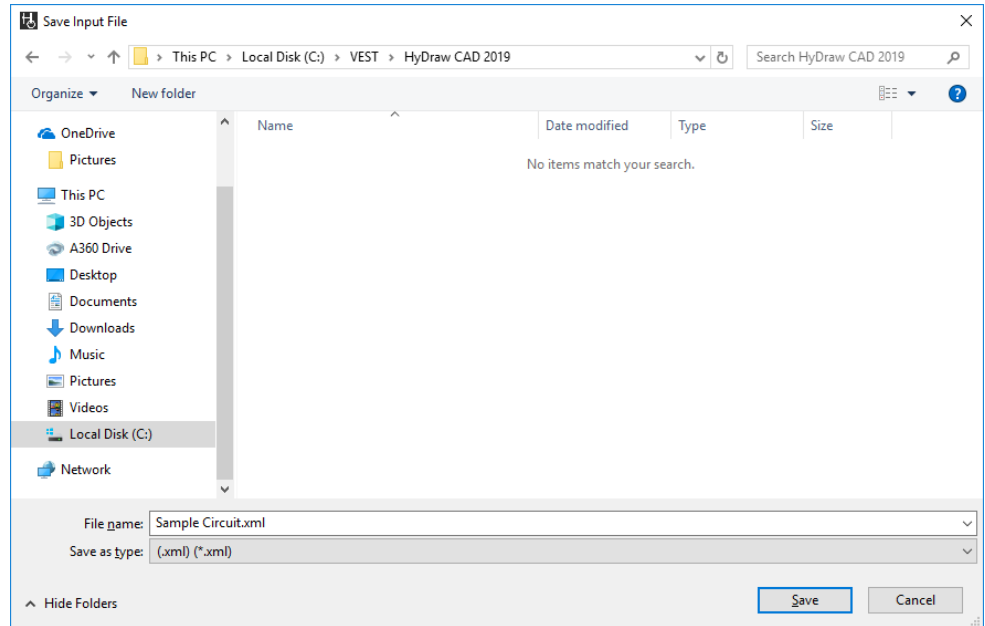

Save Input File dialog box

Convert

HyDraw CAD 2019 Sample Circuit.dwg

Height Rotate Property Display Format Design Notes Port Names Item Hose Balloon Part Ports Hose Net Actuation Note Docs CAD Files MDTools Convert to HyDraw Update Drawing Schematic Check Insert Title Block Edit Title Block Unit Converter

Property Text Show/Hide ID Lists Collate Export Convert Check Title Block Calculator

Start Sample Circuit* x

68 Convert to HyDraw
69 Update Drawing

ITEM ID	QTY	MODEL CODE	DESCRIPTION	MANUFACTURER
1	3	DYN-FF-P-300SAGE	PRESSURE GAUGE 0-5000 PSI	DYNALINE
2	1	SP200	PUMP MOTOR ASSEMBLY	CUSTOM
3	1	P2-L-20	HOSE	YUEN-INDIA
4	1	PS3-00	SUCTION STRAINER	EATON
5	2	AA48P2LN	DIRECT ACTING PRESSURE RELIEF VALVE	PARKER
6	1	CKD3XAN	CHECK VALVE	EATON
7	1	AWENR/VE230MML	DIRECTION CONTROL VALVE	HYDAC
8	1	30AG3050E0020	FILTER	EATON
9	1	CDW-0-L0M	NEEDLE VALVE	HYDAC
10	1	LS67	FLOAT & TEMPERATURE SWITCH	YUEN-INDIA
11	1	BP210	FILLER/BREATHER	YUEN-INDIA
12	1	RMB17022	BLACK HAIR NET CONNECTOR	BOUCH REAROTH

ITEM ID	PORT TYPE	DESCRIPTION	PORT SIZE
BR C LVL R	SAE O-RING	#6 SAE	#6 SAE
MC MP, HR	SAE O-RING	#4 SAE	#4 SAE
P1 P2, PRL T	SAE O-RING	#0 SAE	#0 SAE
TR1	SAE O-RING	#0 SAE	#0 SAE

NET NAME	NET LIST	NET PRESSURE (PSI)
NET-1	MC 4-2, C	5000
NET-2	3-T, T, SA-2	2500
NET-3	3-P, P, P1, MP, SA-1	3500
NET-4	HR, 6-2, R, SB-1	3000
NET-6	3-1, T-8	2500
NET-7	6-1, SB-2, T-4	4000

FUNCTION	3/2V1	3/2V2	HOSE ID	QUANTITY	DESCRIPTION
CYLINDER EXT.	<input type="radio"/>	<input type="radio"/>	3	1	HOSE
CYLINDER RET.	<input type="radio"/>	<input type="radio"/>			

NAME	DATE	COMP
VEST, INC.		

INSERT 1ST DR 3RD ANGLE PROJECTION SYMBOL HERE
 THE DRAWING ORIGIN IS THE POINT OF THE 0,0 COORDINATE SYSTEM. THE POINT OF THE 0,0 COORDINATE SYSTEM IS THE POINT OF THE 0,0 COORDINATE SYSTEM. THE POINT OF THE 0,0 COORDINATE SYSTEM IS THE POINT OF THE 0,0 COORDINATE SYSTEM.

NO.	ISSUE	REV
B	HYDCAD000001	1

ID NET SCALE DENOM
 PAPER MODEL
 1:1
 Model Layout1 +

68. Convert to HyDraw

Converts AutoCAD entities into HyDraw CAD entities.

1. Click **System** > **Convert to HyDraw** on the HyDraw CAD ribbon menu.
The Select Objects prompt displays.
2. After completion of selection, press the **Enter** key.
Convert to HyDraw dialog box displays.
3. Select an Application.

The screenshot shows the 'Convert to HyDraw' dialog box. The title bar reads 'Convert to HyDraw' with a close button (X). The dialog is divided into two sections. The first section, 'Convert to HyDraw Symbol', is selected with a radio button. It contains a dropdown menu for 'Application' set to 'Hydraulic'. Below it is another dropdown menu for 'Component Type' set to 'Electric Motor'. There is an 'Item ID' text box, an 'Insert port' label, and two text boxes for 'Name' and 'Other Name'. An 'Insert' button is located to the right of the 'Other Name' box. The second section, 'Convert to HyDraw Connection', is unselected. It contains a 'Connection type' dropdown menu set to 'Pressure'. At the bottom of the dialog are 'OK' and 'Cancel' buttons.

Convert to HyDraw dialog box

3. Convert to HyDraw Symbol

1. Select a component type.
2. Enter item ID.
3. Insert Port
 - Enter port name.
 - Click Insert.The Specify Port Insertion point prompt displays.

4. Click **OK**.
The Specify Insertion point prompt displays.
5. Specify the insertion point
AutoCAD entities converted into HyDraw
CAD entities.

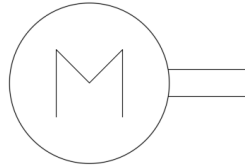

Before Convert to HyDraw Symbol

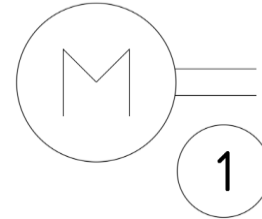

After Convert to HyDraw Symbol

4. Convert to HyDraw Connection

1. Select a Connection type.
2. Click **OK**.
AutoCAD entities converted into HyDraw CAD entities.

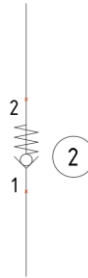

Before Convert to HyDraw Connection

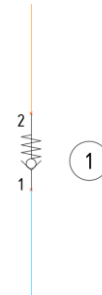

After Convert to HyDraw Connection

69. Update Drawing

Update the Earlier Version connection line properties to the Current Version connection line properties.

Click **System > Update Drawing** from Convert option on the HyDraw CAD ribbon menu.

Connection line properties are automatically updated to current version line properties.

Pipe and Tube connection data and design requirements are automatically restored to the connection lines with connector type, Pipe/Tube/Hose/Drill Hole.



Update Drawing

HYDRAW PROPERTY MANAGER

Selected Item System

Connection

Label	
Connection type	Pressure
Display Setting	

Design requirements

Pressure (psi)	1750
Max Flow (gpm)	25

Connection Data

Pressure (psi)	3400
Flow to Actuator (gpm)	
Flow to Tank (gpm)	
Type	Tube
Size	
Nominal Size	1
Inner Diameter (in)	0.834
Outer Diameter (in)	1
Wall Thickness (in)	0.083
Material	304 SS

Before Update Drawing – Connection Properties

HYDRAW PROPERTY MANAGER

Selected Item System

Connection

Label	
Connection	Pressure
Connector	Tube
Display Setting	

Design requirements

Pressure (psi)	1750
Max Flow (gpm)	25

Connection Data

Pressure (psi)	3400
Flow to Actuator (gpm)	
Flow to Tank (gpm)	
Size	
Nominal Size	1
Inner Diameter (in)	0.834
Outer Diameter (in)	1
Wall Thickness (in)	0.083
Material	304 SS

After Update Drawing – Connection Properties

Check

HyDraw CAD 2019 Sample Circuit.dwg

70 Schematic Check

ITEM ID	QTY	MODEL CODE	DESCRIPTION	MANUFACTURER
1	3	DYN-FF-P30A0AE	PRESSURE GAUGE 0-5000 PSI	DYNAPAC
2	1	SP200	PUMP MOTOR ASSEMBLY	CUSTOM
3	1	P2-L-20	HOSE	YUEN-INDIA
4	1	P3L-00	SUCTION STRAINER	EATON
5	2	AA48P2-LN	DIRECT ACTING PRESSURE RELIEF VALVE	PARSON
6	1	CKD3XAN	CHECK VALVE	EATON
7	1	AWERXK/EV230MML	DIRECTION CONTROL VALVE	HYDAC
8	1	30AG350E0020	FILTER	EATON
9	1	CD10-L-0M	NEEDLE VALVE	HYDAC
10	1	LS67	FLOAT & TEMPERATURE SWITCH	YUEN-INDIA
11	1	BP210	FILLER/BREATHER	YUEN-INDIA
12	1	BM010022	BLACK HAIR NET CONNECTOR	BOUCH REAR/OTM

ITEM ID	PORT TYPE	DESCRIPTION	PORT SIZE
BR C LVL R	SAE O-RING	#4 SAE	#4 SAE
MC MP, MR	SAE O-RING	#4 SAE	#4 SAE
P1 P2, PRL T	SAE O-RING	#0 SAE	#0 SAE
TR1	SAE O-RING	#0 SAE	#0 SAE

NET NAME	NET LIST	NET PRESSURE (PSI)
NET-1	MC 4-2, C	5000
NET-2	3-T, T, SA-2	2500
NET-3	3-P, P, P1 MP, SA-1	3500
NET-4	MR 6-2, R, SB-1	3000
NET-6	3-L, T-B	2500
NET-7	3-L, SB-2, T-A	4000

FUNCTION	3-2/1	3-2/2	HOSE ID	QUANTITY	DESCRIPTION
CYLINDER EXT.	<input type="radio"/>	<input type="radio"/>	3	1	HOSE
CYLINDER RET.	<input type="radio"/>	<input type="radio"/>			

NAME	DATE	COMP
VEST, INC.		

REV	DATE	BY
1		

Model Layout1 PAPER MODEL 1:1

70.Schematic Check

Reports the components/external ports data error and connections error in the drawing.

This feature enables you to check the drawing for:

- Component/Port/Envelope missing data
- Item ID/Port Name not specified
- Duplicate Item ID/Port Name
- Items not included in Parts list
- Hanging connection
- Overlapping connection
- Validation of Connection
- Self crossing line
- Multiple connections from single port

1. Click **System > Schematic Check** from Check option on the HyDraw CAD ribbon menu.

The Schematic Check dialog box displays.

2. Select the parameters you want to check.
3. Select **Zoom on selection**, if you want to zoom into problem area on selecting error in the report.
4. Click **Check**.

HyDraw® checks the schematic drawing for the selected parameters and lists the error report in the dialog box.

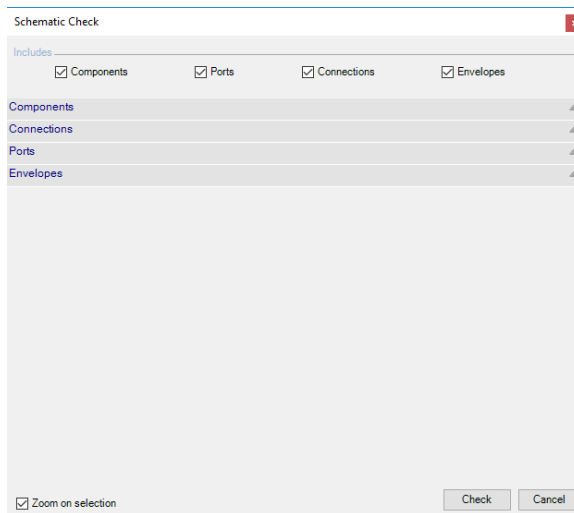

Schematic Check dialog box

Error Type

Components:

Model Code Missing:

Model code is not available in the component.

Item ID Missing:

Item ID is not specified in the component.

Duplicate Item ID:

Multiple components having same Item ID in the drawing.

Item not included in Parts List:

Include in parts list option is unchecked in the HyDraw Property Manager for the component.

Ports Not Connected:

Component symbol Ports neither connected nor blocked.

External Ports:

Port Size Missing

Port size is missing in the external port name.

Duplicate Port Name

Multiple external ports having same port name in the drawing.

Ports Not Connected:

Ports neither connected nor blocked.

Connection Lines:

Hanging Connection

Connection line one end or both ends are unconnected.

Overlapping Connections

Two or more connection lines exist at same location.

Self-Crossing Line

One end of the connection line crossing the other end of the same connection line

Multiple Connections from Single Port

Multiple connection lines are connected to a single port.

Connection Validation

Potentially wrong connections with incorrect Connection Types in the drawing.

Envelopes:

Model Code Missing:

Model code is not available in the Envelope.

Item ID Missing:

Item ID is not specified in the Envelope.

Duplicate Item ID:

Multiple Envelopes having same Item ID in the drawing.

Item not included in Parts List:

Include in parts list option is unchecked in the HyDraw Property Manager for the Envelope.

Schematic Check

Includes Components Ports Connections Envelopes

Components

Items	Error Type
5	Duplicate Item ID
Component [1]	Item ID missing,Item not included in Parts List
2	Model Code missing
11	1 is not connected

Connections

Items	Error Type
Connection 1	Hanging connection,Overlapping connection
Connection 2	Hanging connection,Self-crossing connection
Connection 3	Hanging connection,Suction and Reservoir is connected.
Connection 4	Multiple connection from single port,Overlapping connection
Connection 5	Multiple connection from single port,Overlapping connection
Connection 6	Pressure and Drain is connected.
Connection 7	Reservoir and Pressure is connected.
Connection 8	Overlapping connection

Ports

Items	Error Type
MC	Duplicate Port Name
P2	Port Size missing
BR	1 is not connected

Envelopes

Items	Error Type
13	Model Code missing
13	Duplicate Item ID
Envelope [1]	Item ID missing

Zoom on selection

Schematic Check Report

Title Block

HyDraw CAD 2019 Sample Circuit.dwg

71 Insert Title Block
72 Edit Title Block

Parts List

ITEM ID	QTY	MODEL CODE	DESCRIPTION	MANUFACTURER
1	3	DYN-OP-P30A3AE	PRESSURE GAGE, 0-5000 PSI	DYNAMIC
2	1	BP1700	PUMP MOTOR ASSEMBLY	CUCTION
3	1	Z1-10	HOSE	YUEN-INDIA
4	1	P28-100	SUCTION CONTAINER	EATON
5	2	AA80B22AN	DIRECT ACTING PRESSURE RELIEF VALVE	PAWEN
6	1	C20A1AH	SHOCK VALVE	EATON
7	1	AWEN3AN/REV230NH4	DIRECTION CONTROL VALVE	HYDAC
8	1	50AG3050P0020	FILTER	EATON
9	1	LD 0-1-1-0M	NEEDLE VALVE	HYDAC
10	1	LSB7	FLOAT & TEMPERATURE SWITCH	YUEN-INDIA
11	1	BR210	FILLER/BREATHER	YUEN-INDIA
12	1	BR017021	BLACK MATING CONNECTOR	BOCHIKI REIKROT

Net List

NET NAME	NET LIST	NET PRESSURE (PSI)
NET-1	MC 9-2, C	3000
NET-2	R-1, L, SA-1	2500
NET-3	P28, P1, P1, MP, SA-1	2500
NET-4	MR, 6-1, R, SB-1	2000
NET-6	1-1, 1-2	2500
NET-7	6-1, SB-2, 1-4	4000

Function Table

FUNCTION	1, 5/11	5, 5/2	HOSE ID	QUANTITY	DESCRIPTION
CYLINDER EXT.	○	○	3	1	HOSE
CYLINDER RET.	○	○			

Metadata

REV	DATE	BY	COMPANY
1			VEST, INC.

Project Information

NAME	DATE	REV
CYLINDER CONTROL		1

HYDRA-CAD 20190001

71.Insert Title Block

Insert a HyDraw Title block to the drawing.

1. Click **System > Insert Title Block** on the HyDraw CAD ribbon menu.

Insert Title Block dialog box displays.

2. Select Sheet Size.

3. Click **OK** and Exit.

HyDraw Title Block inserted into the drawing.

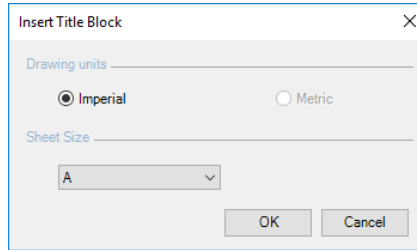

Insert Title Block dialog box

Note:

By default, drawing units comes as per unit selection in the HyDraw Options.

72.Edit Title Block

Edit all properties in the Title block.

1. Click **System > Edit Title Block** on the HyDraw CAD ribbon Menu.

Edit Title Block dialog box displays.

2. Select a property.
3. Enter a value.
4. Select **Export**, if required.

The Save As dialog box displays.

5. Enter an appropriate file name.

6. Click **Save**.

Title Block attributes saved as Text file.

7. Click **OK** in Edit Title Block Dialog.

Values updated in the inserted Title block.

Import

1. Click **System > Edit Title Block** on the HyDraw CAD ribbon menu.

The Edit Title Block dialog box displays.

2. Select **Import**.

The Select File dialog box displays.

3. Select the text file with Block attributes.

4. Click **Open**.

Property values updated in the dialog box.

5. Click **OK**.

Values updated in the inserted Title block.

Property Name	Value
Revision Number	1
Drawing Scale	1.1
Finish Type	
Material Type	STEEL
Title	CYLINDER CONTROL
Company Name	VEST, INC.
Sheet Size	B
Sheet Number	1
Drawn Name	CA
Drawn Date	02/05/2018
Checked Name	JA
Checked Date	02/05/2018
Approved Name	JA
Approved Date	03/05/2018
Drawing Number	HYDCAD2019001

Edit Title Block dialog box

FluidPowerTools.com

FluidPowerTools.com : C: X

www.fluidpowertools.com

Hydraulics - Stock Pl: Image Placeholders Photoshop Photogra: Out Of The Ordinary VEST airtel Smartbytes | Br: >> | Other bookmarks

Home | About Us | Contact Us | Subscribe

Engineering and Design Resources

Component Data Manufacturers Tools Services

Fluid Power Resources

Questions?
01 (248) 649 9550
email: support@VESTusa.com

73 Data Access Settings
74 Help for FluidPowerTools.com
75 Internet Settings

Eaton Slip-in Cartridge Valves component data added.

FluidPowerTools.com gives real time access to fluid power data and resources. It is promoted by VEST, Inc. the pioneer in engineering design software and services for the fluid power industry.

Engineering and design data of Fluid Power components of major manufacturers delivered by FluidPowerTools.com

Rexroth Bosch Group Eaton sun hydraulics CORPORATION HYDAC

Parker SAUER DANFOSS atos HYDRAFORCE High Performance Hydraulic Cartridge Valves and Electro-Hydraulic Control Systems

FluidPowerTools is a trademark of VEST, Inc. All other company and product names mentioned herein are trademarks or registered trademarks of their respective owners. FluidPowerTools is not affiliated to any of the manufacturers listed.

Feedback | Privacy | Terms & Conditions, Disclaimer | Trademarks © 2017 VEST, Inc.

73. Data Access Settings

Select Manufacturer database to search components.

1. Click Services > **Data Access Settings** on the FluidPowerTools section on the HyDraw® CAD ribbon menu.

The FluidPowerTools.com Data Access Settings dialog box displays.



Data Access Settings Menu Item

2. Select the required Manufacturers from the list and click **OK**.

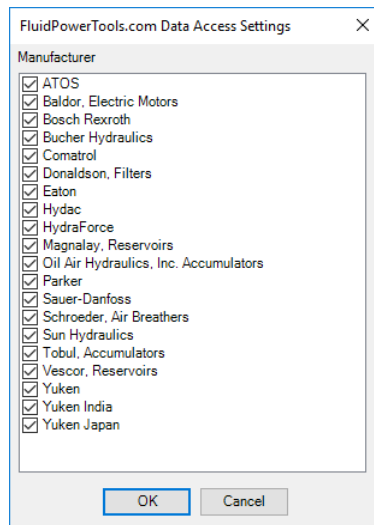

Data Access Settings dialog box

74.Help for FluidPowerTools.com

1. Subscription Information

Know the HyDraw® version and subscription information.

Click Services > **Subscription Information** on the FluidPowerTools section of the Services tab in the HyDraw CAD ribbon menu.

The FluidPowerTools.com - Data Service information box displays.

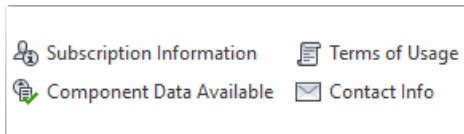

Help menu and submenu

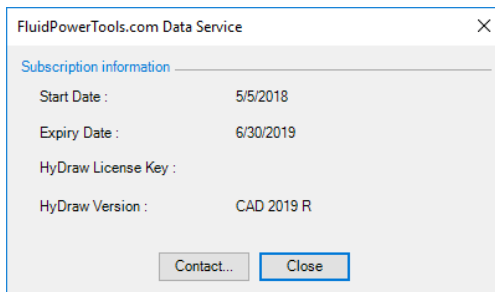

The FluidPowerTools.com Data Service

2. Component Data Available

Navigate to FluidPowerTools.com, where you can see the component data of major Fluid Power manufacturers.

Click Services > **Component Data Available** on the FluidPowerTools section of the HyDraw® CAD ribbon menu.

The screenshot shows a web browser window displaying the FluidPowerTools.com website. The page title is "Screw-in Cartridge Valves". A navigation menu includes "Component Data", "Manufacturers", "Tools", and "Services". The "Component Data" section is active, showing a list of valve types with "Screw-in Cartridge Valves" selected. A table lists various valve types and their availability from nine manufacturers: Bosch Rexroth, Command Controls, Eaton, Hydac, Hydra Force, Parker, Sauer Danloss, and Sun Hydraulics. Green checkmarks indicate availability for each manufacturer.

Screw-in Cartridge Valves	Bosch Rexroth	Command Controls	Eaton	Hydac	Hydra Force	Parker	Sauer Danloss	Sun Hydraulics
Check Valves	✓	✓	✓	✓	✓	✓	✓	✓
Pilot Op. Check Valves	✓	✓	✓	✓	✓	✓	✓	✓
Shuttle Valves	✓	✓	✓	✓	✓	✓	✓	✓
Flow Control Valves	✓	✓	✓	✓	✓	✓	✓	✓
Needle Valves	✓	✓	✓	✓	✓	✓	✓	✓
Flow Divider /Combiner Valves	✓	✓	✓	✓	✓	✓	✓	✓
Counterbalance and Load Control Valves	✓	✓	✓	✓	✓	✓	✓	✓
Pressure Relief Valves	✓	✓	✓	✓	✓	✓	✓	✓
Pressure Reducing Valves	✓	✓	✓	✓	✓	✓	✓	✓
Pressure Sequence Valves	✓	✓	✓	✓	✓	✓	✓	✓
Pressure Unloading Valves	✓	✓	✓	✓	✓	✓	✓	✓
Direction Control Valves - Manually Operated	✓	✓	✓	✓	✓	✓	✓	✓
Direction Control Valves - Hydraulic Pilot Operated	✓	✓	✓	✓	✓	✓	✓	✓
Direction Control Valves - Solenoid Operated	✓	✓	✓	✓	✓	✓	✓	✓
Logic Elements	✓	✓	✓	✓	✓	✓	✓	✓
Proportional Flow Control Valves	✓	✓	✓	✓	✓	✓	✓	✓
Proportional Pressure Relief Valves	✓	✓	✓	✓	✓	✓	✓	✓
Proportional Pressure Reducing Valves	✓	✓	✓	✓	✓	✓	✓	✓
Proportional Direction Control Valves	✓	✓	✓	✓	✓	✓	✓	✓
Accumulator Discharge Valves	✓	✓	✓	✓	✓	✓	✓	✓
Hand pumps	✓	✓	✓	✓	✓	✓	✓	✓

FluidPowerTools.com is working to provide more data libraries from other manufacturers including libraries of pumps, motors, gauges, accumulators, hoses, heat exchangers etc. If you want your company data to be included, please contact VEST Inc.

Feedback | Privacy | Terms & Conditions, Disclaimer | Trademarks © 2017 VEST, Inc.

The FluidPowerTools.com - Component Data

3. Terms of Usage

Navigate to FluidPowerTools.com, where you can see the terms and conditions of using the services on FluidPowerTools.com

Click Services > **Terms of Usage** on the FluidPowerTools section on the HyDraw® CAD ribbon menu.

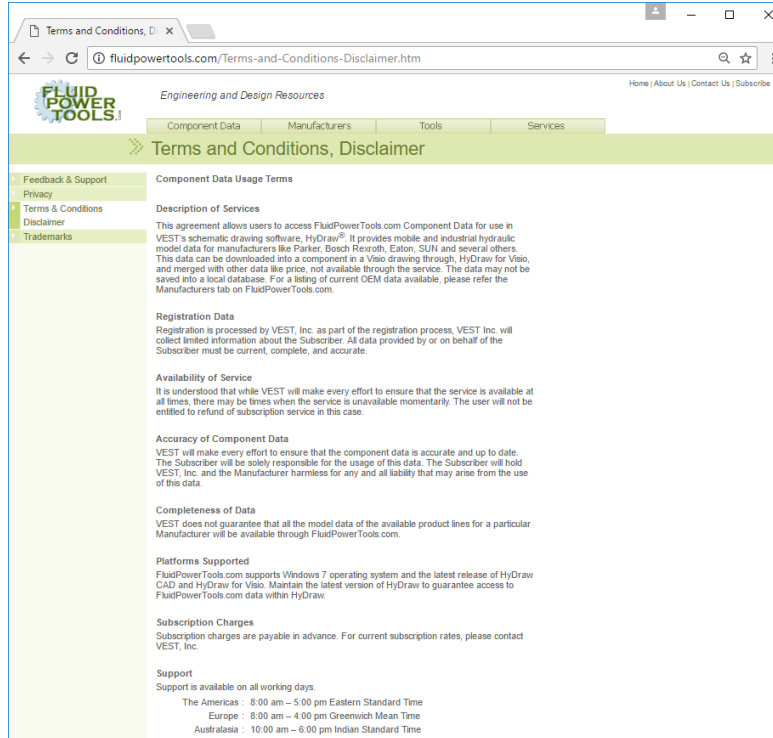

The screenshot shows a web browser window displaying the 'Terms and Conditions, Disclaimer' page on FluidPowerTools.com. The page features the FluidPowerTools logo and navigation tabs for 'Component Data', 'Manufacturers', 'Tools', and 'Services'. A left-hand sidebar contains a menu with items like 'Feedback & Support', 'Privacy', 'Terms & Conditions', 'Disclaimer', and 'Trademarks'. The main content area is titled 'Terms and Conditions, Disclaimer' and includes sections for 'Component Data Usage Terms', 'Description of Services', 'Registration Data', 'Availability of Service', 'Accuracy of Component Data', 'Completeness of Data', 'Platforms Supported', 'Subscription Charges', and 'Support'. The 'Description of Services' section states that the agreement allows users to access FluidPowerTools.com Component Data for use in VEST's schematic drawing software, HyDraw®, and provides mobile and industrial hydraulic model data for manufacturers like Parker, Bosch Rexroth, Eaton, SUN, and several others. It also mentions that data can be downloaded into a component in a Visio drawing through HyDraw for Visio, and merged with other data like price, not available through the service. The 'Registration Data' section notes that registration is processed by VEST, Inc. as part of the registration process, and VEST Inc. will collect limited information about the Subscriber. The 'Availability of Service' section states that VEST will make every effort to ensure the service is available at all times, but there may be times when the service is unavailable momentarily. The 'Accuracy of Component Data' section states that VEST will make every effort to ensure that the component data is accurate and up to date. The 'Completeness of Data' section states that VEST does not guarantee that all the model data of the available product lines for a particular Manufacturer will be available through FluidPowerTools.com. The 'Platforms Supported' section states that FluidPowerTools.com supports Windows 7 operating system and the latest release of HyDraw CAD and HyDraw for Visio. The 'Subscription Charges' section states that subscription charges are payable in advance. The 'Support' section states that support is available on all working days, with contact information for The Americas (8:00 am – 5:00 pm Eastern Standard Time), Europe (8:00 am – 4:00 pm Greenwich Mean Time), and Australasia (10:00 am – 8:00 pm Indian Standard Time).

The FluidPowerTools.com Terms and Conditions, Disclaimer

4. Contact Info.

Navigate to *FluidPowerTools.com*, where you can find the contact information of the VEST team.

Click Services > **Contact Info** on the FluidPowerTools section on the HyDraw® CAD ribbon menu.

The screenshot shows a web browser window with the URL fluidpowertools.com/Contact-Us.htm. The page features the FluidPowerTools logo and navigation tabs for Component Data, Manufacturers, Tools, and Services. The main content is titled "Contact Us" and is organized into two columns. The left column contains a sidebar with "About Us" (sub-menu: About Us, Contact Us, Subscribe) and "European Representative". The right column contains contact details for "Headquarters" (VEST, Inc.) and "European Representative" (Ing. Carlo Molon). Two Google Maps are included: one for VEST, Inc. at 3250 W. Big Beaver Road, Suite 440, Troy, MI, and another for Via Mestrina, 20 in Mestrina, Italy. The footer contains links for Feedback, Privacy, Terms & Conditions, Disclaimer, and Trademarks, along with a copyright notice for VEST, Inc. © 2017.

Location	Contact Information
Headquarters (VEST, Inc.)	3250 W. Big Beaver Road, Suite 440 Troy, MI 48084 USA Tel: +1 (248) 649-9550 Fax: +1 (248) 649-9560 Email: sales@VESTusa.com support@VESTusa.com
European Representative (Ing. Carlo Molon)	via Mestrina, 20 35035, Mestrina, PD, Italy Tel: +39 049 997 00 40 Mob: +39 328 695 70 01 Fax: +39 049 997 00 41 Email: info@fluidpower.it Web: www.fluidpower.it www.fluidpower.fr

The FluidPowerTools.com - Contact Info

75. Internet Settings

Configure the Internet settings for FluidPowerTools.com.

1. Click Services > **Internet Settings** on the Setup section of the Services tab on the HyDraw® CAD ribbon menu.

The Internet Settings tab page displays.

2. Configure the connection, per requirement.
3. Click **OK** to apply and exit.

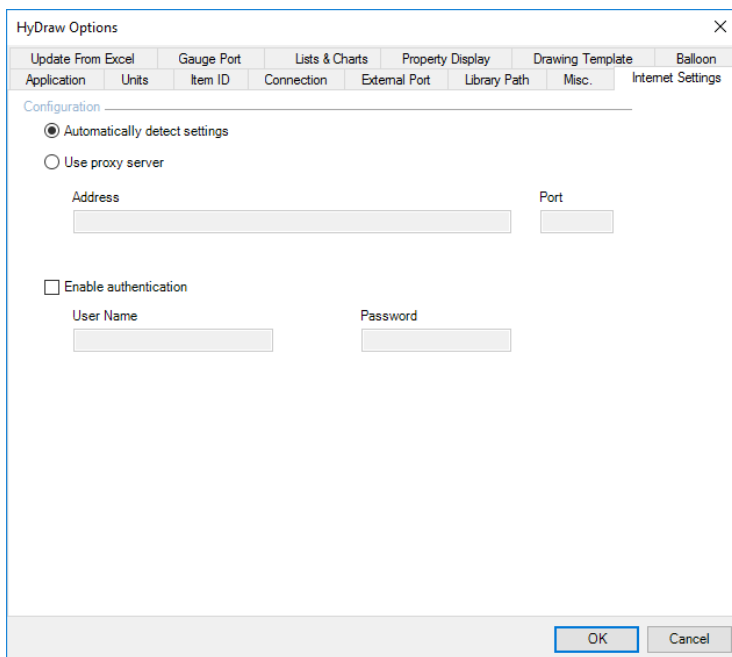

The screenshot shows the 'HyDraw Options' dialog box with the 'Internet Settings' tab selected. The dialog has a title bar with a close button (X) and a menu bar with the following items: Update From Excel, Gauge Port, Lists & Charts, Property Display, Drawing Template, Balloon, Application, Units, Item ID, Connection, External Port, Library Path, Misc., and Internet Settings. The 'Internet Settings' tab is active, showing a 'Configuration' section with the following options:

- Automatically detect settings
- Use proxy server

Below these options are two input fields: 'Address' and 'Port'. The 'Address' field is currently empty, and the 'Port' field contains the number '80'. Below these fields is a checkbox labeled 'Enable authentication', which is currently unchecked. Below this checkbox are two input fields: 'User Name' and 'Password', both of which are currently empty. At the bottom right of the dialog are two buttons: 'OK' and 'Cancel'.

HyDraw Options: Internet Settings

HyDraw CAD Help

HyDraw® CAD 2019

'Power-to-Design' Circuits

Help



76	Help
77	License Information
78	About HyDraw

76.Help

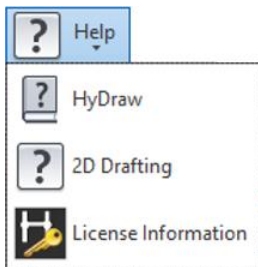

Help Command Menu and Sub menu

HyDraw

The HyDraw command opens the HyDraw® CAD 2019 Help

2D Drafting

The 2D Drafting command opens the 2D drafting help file for HyDraw CAD 2019.

License Information

The License Information command opens the HyDraw® CAD 2019 License.

Details. Refer Ch.77

77. License Information

HyDraw License Information displays - Version Number, Build number, License type, License key, License Status, Expiration Date, Serial number and Borrow details.

Network License

1. Click Help > Help > **License Information**.

HyDraw CAD 2019 License Details dialog displays.

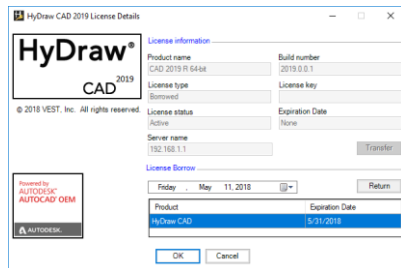

Network License Details - Borrowed

5. Click **Return** to release the Borrowed* Network License.

License returned successfully message displays.

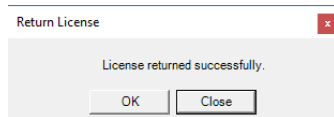

6. Click **OK**.

Note:

- Borrow option available for Network License only.
- Transfer option available for Standalone License only.

Standalone License

1. Click **Help > Help > License Information**.

HyDraw CAD 2019 License Details dialog displays.

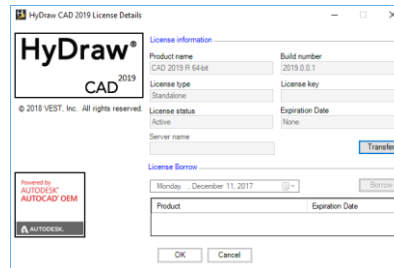

Transfer License

1. Click **Transfer** to switch the HyDraw Standalone License to a different computer/system.

HyDraw CAD 2019 Authorization dialog displays.

2. Click **Next** and **Create Request**.
License Transfer warning displays.

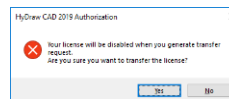

License Transfer Warning

3. Click **Yes**.
Transfer request is generated and prompts to save in an xml file.
4. Attach Transfer Request file to an email and send it to support@VESTusa.com.

78.About HyDraw

Displays product information.

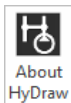

About HyDraw Menu item

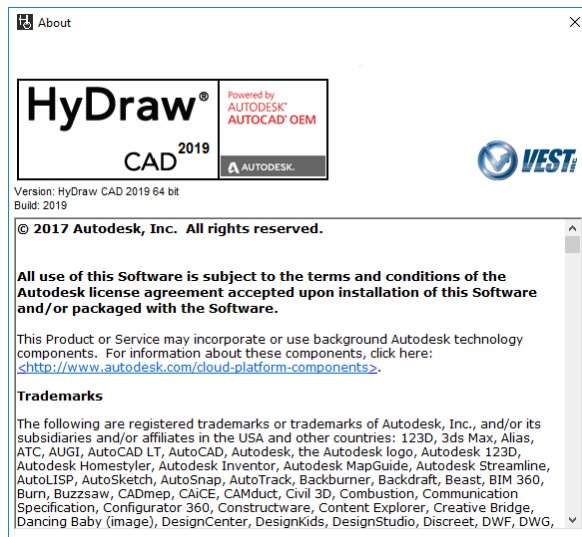

About HyDraw dialog box

Installation & Setup

HyDraw CAD 2019

HyDraw®
CAD 2019

VEST

- 79 HyDraw CAD 2019 Installation
- 80 Library Network Configuration
- 81 Set Online Services (FPT)
- 82 Build New Symbols
- 83 Build External Port Symbols
- 84 Build New Sub-Systems
- 85 Manage HyDraw CAD Drawings through Vault

Install
Install on this computer

Installation Help | System Requirements | Readme

Exit

79.HyDraw CAD 2019 Installation

The HyDraw® installation program installs HyDraw CAD 2019 on your computer.

1. System Requirements:

The system requirements are provided in the product documentation.

Software

- Microsoft Windows 10, Microsoft Windows 8.1 with Update KB2919355, Microsoft® Windows® 7 SP1(64-bit).
- .Net Framework 4.6.
- Microsoft Internet Explorer® 11.0 or later.
- Adobe Reader 10 or higher.
- Excel 2013* or higher.

* Required only for exporting HyDraw data.

Note:

HyDraw CAD 2019 is compatible with 64-bit Operating System, If required, install 32/64-bit Office 2013/2016 on 64-bit Operating System.

Hardware

- **Processor:** 1 gigahertz (GHz) or faster 64-bit (x64) processor.
- **Memory:** 8 GB RAM or more.
- **Display Resolution:** 1360 x 768 (1920 x 1080 recommended) with True Color
- **Hard Disk:** 6.0 GB free disk space

Note:

The minimum required configuration is listed above. It is recommended to use a higher hardware configuration for power users.

2. Software Installation

1. Run the self-extracting exe, HyDraw CAD 2019.0.0.5 R x64 - EN Setup.exe/HyDraw CAD 2019.0.0.5 R x64 – IT from the downloaded installation and unzip.

or

Insert the HyDraw® CAD 2019 DVD into the DVD-ROM drive.

If Auto Run is not set, then:

- a) On the Start menu, click **Run**.
- b) Browse to the Setup.exe program on the CD-ROM drive.
- c) Select **Setup.exe** and click **Open**.
- d) Click **OK**.

The HyDraw CAD installation program dialog box displays.

2. Click **Install Products** to install the HyDraw CAD application.
3. Accept the **License Agreement** and click **Next**.

The Software can be configured for both typical and custom installation.

4. After Configuration, click **Configuration Complete**.
5. Click **Install**.

View the HyDraw CAD User Manual and the ReadMe file from the Documentation section, if required.

6. Once complete, click **Finish** in the HyDraw CAD 2019 dialog box and Restart your computer for the changes to take effect.

HyDraw CAD 2019 and HyDraw Library Manager 2019 are installed on the system and HyDraw CAD 2019 is displayed in the Windows Start > All Apps.

A HyDraw CAD 2019 shortcut icon is created on the desktop.

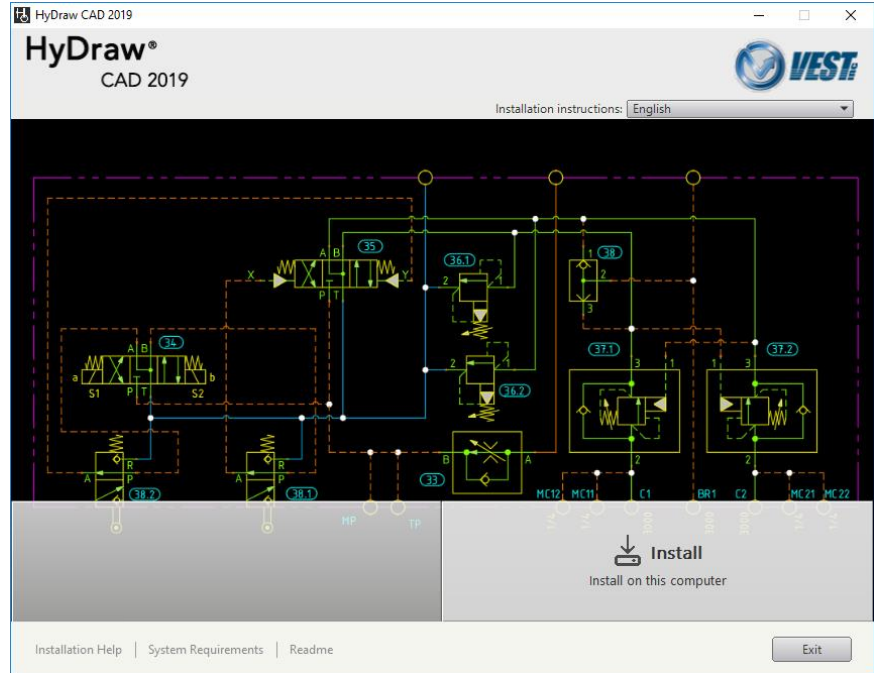

HyDraw CAD Installation screen

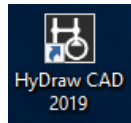

HyDraw CAD 2019 desktop icon

3. Usage Authorization

HyDraw® CAD 2019 could be authorized with Standalone License or Network License based on the purchase. The Program could be evaluated using 30 days Trial Period.

1. Submit Standalone Authorization Request

1. Double click the **HyDraw® CAD 2019** desktop icon.

The HyDraw CAD 2019 Authorization dialog box displays.

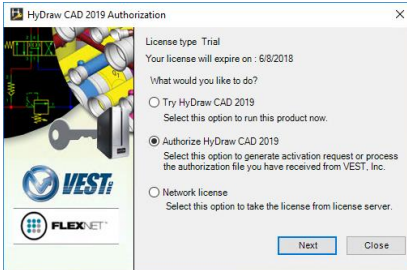

2. Select **Authorize HyDraw CAD 2019**.

3. Click **Next**.

4. Enter the **Serial Number** provided when you purchased the software.

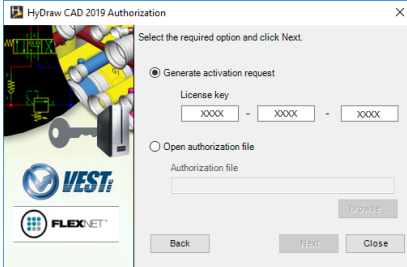

5. Click **Next**.

6. Enter your contact details.

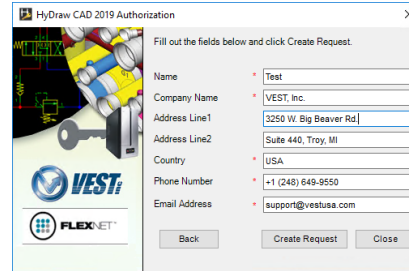

7. Click **Create Request**.

Authorization request is generated and prompts to save in an xml file.

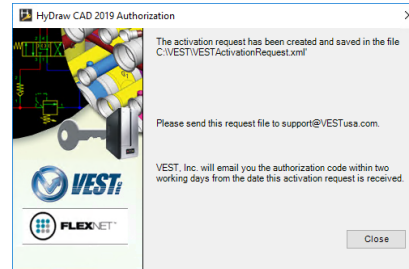

8. Attach the request file to an email and send it to **support@VESTusa.com**.

9. Click **Close**.

2. Authorize Standalone License

1. Double click the **HyDraw® CAD 2019** desktop icon.

If the program is not authorized, then the License Server Product Authorization dialog box displays.

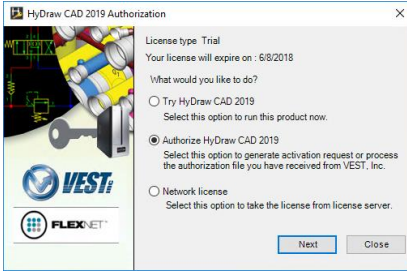

2. Select Authorize HyDraw CAD 2019.
3. Click **Next**.

The HyDraw CAD 2019 Authorization dialog box displays.

4. Select Open authorization file.

5. Click **Browse** and select the saved Authorization code XML file.

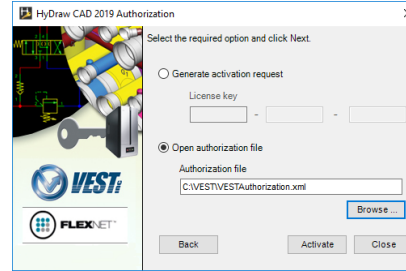

6. Click **Activate**.

Confirmation message displays: Your HyDraw Installation has been authorized Successfully.

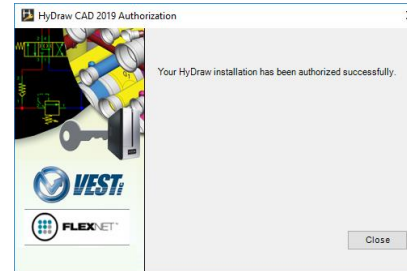

7. Click **Close**.

The dialog box closes, and HyDraw License is successfully activated.

Note:

For checking HyDraw License Details, refer Ch77.

3. Use and Borrow Network License

The HyDraw® client machines can use a network license available from the HyDraw License Server Manager.

Using Network License

1. Double click the **HyDraw® CAD 2019** desktop icon.

The HyDraw CAD 2019 Authorization dialog box displays.

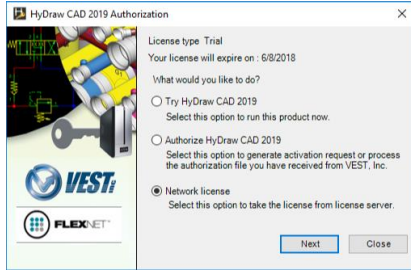

2. Select the **Network license** option.
3. Click **Next**.
4. Set the License Server Name/IP Address and Port number.

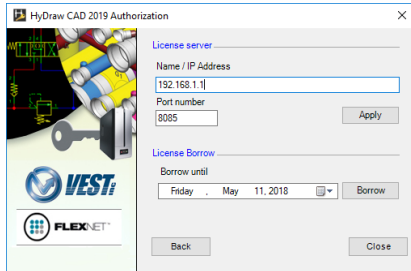

5. Click **Apply**.

Borrowing Network License

6. Select the **Borrow until** date.

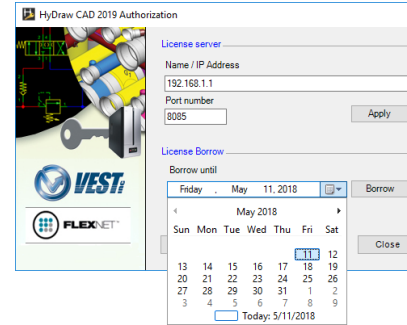

7. Click the **Borrow** button.
The Borrowed license details are displayed in the grid.
8. Click **Close** to exit.

Note:

For checking HyDraw License Details, refer Ch77.

4. Migrate Settings

Migrate the HyDraw® settings of old version to HyDraw CAD 2019.

1. Select, Start
 - > All Apps
 - > HyDraw CAD 2019
 - > **Migrate HyDraw CAD 2019 Settings**

The Migrate HyDraw Settings message box displays.

2. Click **Yes** to migrate old version of HyDraw settings to HyDraw CAD 2019 settings.

Note:

Migrate settings will override the existing settings.

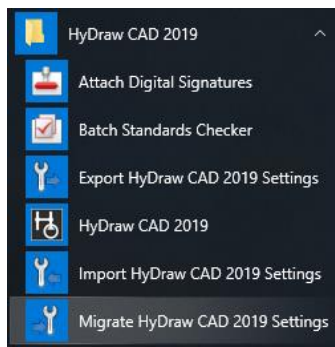

Migrate Settings

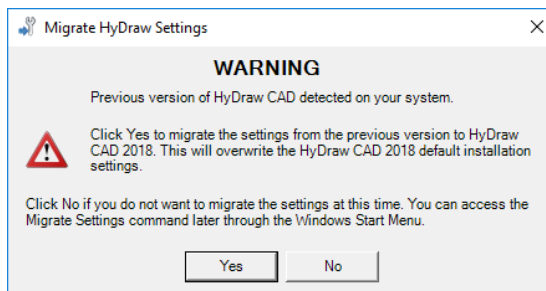

Migrate Settings Message Box

5. Export Settings

Export the existing HyDraw® settings.

1. Select, Start
 - > All Apps
 - > HyDraw CAD 2019
 - > **Export HyDraw CAD 2019 Settings**

The Export HyDraw Settings message box displays.

2. Click **OK** to open the Browse folder.
3. Select the folder where you want to export all the HyDraw Settings files.
4. Click **OK** to save and exit.

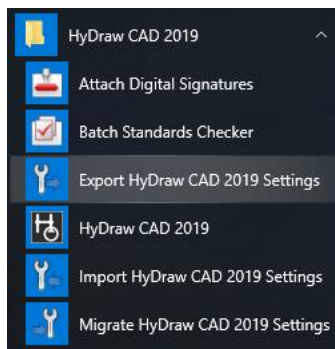

Export Settings

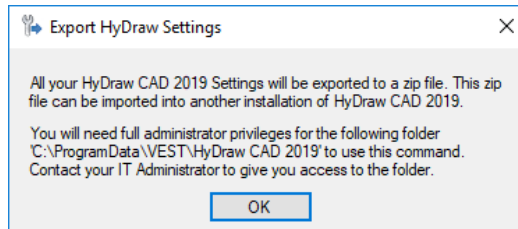

Export Settings Message Box

6. Import Settings

Import the HyDraw® settings to the existing HyDraw settings.

1. Select, Start
 - > All Apps
 - > HyDraw CAD 2019
 - > **Import HyDraw CAD 2019 Settings**

The Import HyDraw Settings message box displays.

8. Click **Yes**.
The File Select dialog box displays.
9. Select the HyDraw settings zip file to import.
10. Click **OK** to exit.

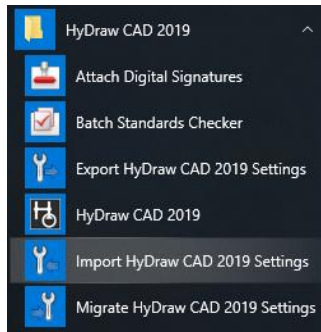

Import Settings

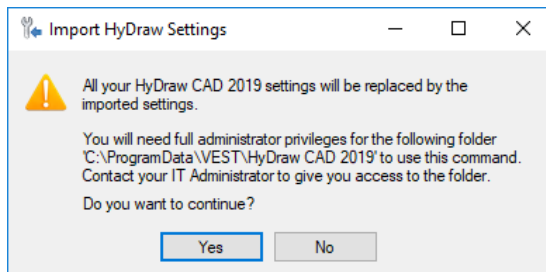

Import HyDraw Settings Message box

80. Library Network Configuration

HyDraw® CAD 2019 can access data from the HyDraw library on a local network.

This enables all designers in an organization to work efficiently by sharing a common data resource.

For details on installing the HyDraw Library, refer the Library Manager User Manual.

Library Network Configuration

1. Select Circuit > **Options** from the HyDraw CAD 2019 ribbon menu.

The HyDraw Options dialog box displays.

2. Select the **Library Path** tab.
3. Select the **Corporate Library** option.
4. Select **Enable modification**, if you want to modify your library.
5. Click Browse...
6. Navigate to the folder, where your HyDraw Library data is installed.
7. Repeat step 2, 3, and 4 for each of the specified HyDraw data paths.
8. Click **OK**.

All HyDraw Library paths are configured as selected.

Note:

All data paths shown are default.

You can configure to common network data paths.

The screenshot shows the 'HyDraw Options' dialog box with the 'Library Path' tab selected. The dialog has a title bar with a close button (X) and a menu bar with options: Update From Excel, Gauge Port, Lists & Charts, Property Display, Drawing Template, and Balloon. Below the menu bar are sub-tabs: Application, Units, Item ID, Connection, External Port, Library Path (selected), Misc., and Internet Settings. The 'Local Library' section is selected with a radio button and includes a checked 'Enable modification' checkbox. It has three text input fields for 'Data', 'Symbols', and 'Sub-Systems', each with a 'Browse...' button. The paths are: C:\VEST\HyDrawLibrary2019\Data, C:\VEST\HyDrawLibrary2019\Symbol Library, and C:\VEST\HyDrawLibrary2019\SubSystems. The 'Corporate Library' section is unselected and has an unchecked 'Enable modification' checkbox and three empty text input fields with 'Browse...' buttons. At the bottom right are 'OK' and 'Cancel' buttons.

HyDraw CAD library default paths

81.Set Online Services (FPT)

Internet Settings for accessing FluidPowerTools.com

1. Automatically detect settings

If your computer is connected to the Internet through a direct LAN connection, then select the **Automatically detect settings** option.

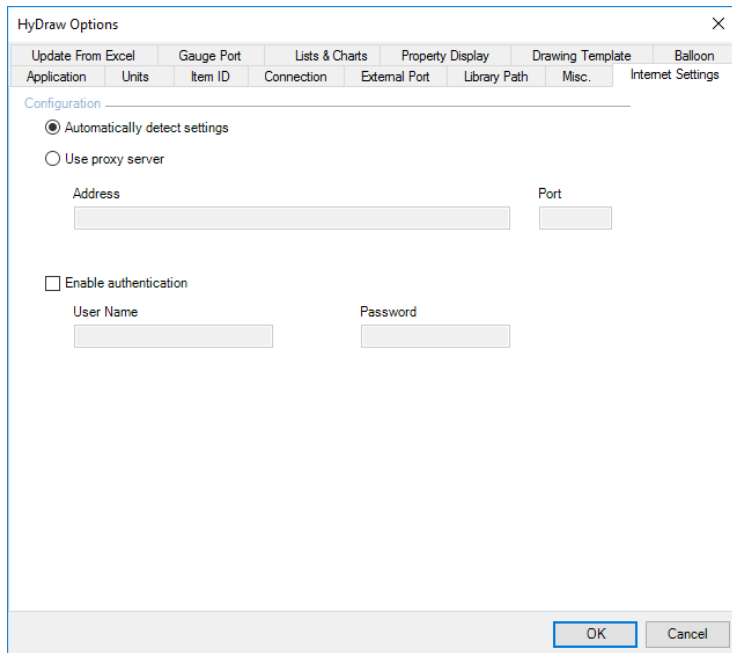

Connection Settings – Direct Connection

1. Proxy Connection

If your computer is connected to the Internet through a web proxy server, then select Use proxy server.

Configure the proxy settings.

1. Enter the address.
2. Enter the port number.
3. Enter authentication details, if required.

You may refer to the settings that may be already defined in your web browser.

Note:

- If an automatic configuration script is used in the browser for proxy, then use the Proxy server settings from the LAN Settings dialog box in the browser to configure your Proxy Connection settings.
- If you do not find proxy server details in the browser, then contact your system administrator.

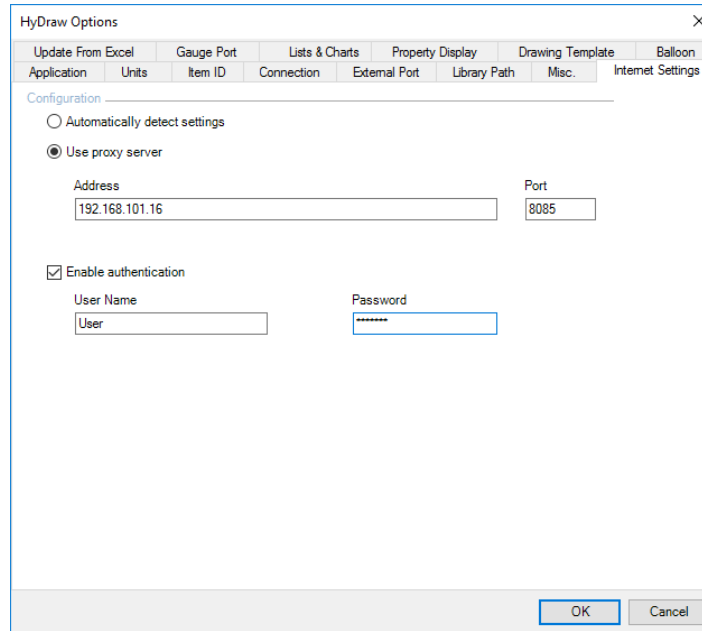

The screenshot shows the 'HyDraw Options' dialog box with the 'Internet Settings' tab selected. The 'Configuration' section has two radio buttons: 'Automatically detect settings' (unselected) and 'Use proxy server' (selected). Below this, there are two text input fields: 'Address' containing '192.168.101.16' and 'Port' containing '8085'. The 'Enable authentication' checkbox is checked. Below it are two text input fields: 'User Name' containing 'User' and 'Password' containing a masked password '*****'. At the bottom right, there are 'OK' and 'Cancel' buttons.

Connection Settings – Proxy Settings

82. Build New Symbols

Create symbols from the building elements supplied along with the library.

In the HyDraw® Library Explorer, browse to the required folder, where you want to add a new symbol.

1. Click Manage Symbol.
2. Select **Build New** symbol from the drop down.

The Build New Symbol window displays.

The basic building block elements are structured in logical folders for easy access.

3. Browse to the required folder.

The Basic Building Elements are displayed in the right side window.

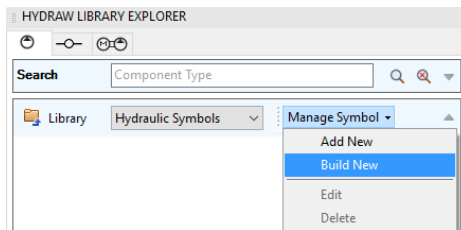

Manage Symbol - Build New

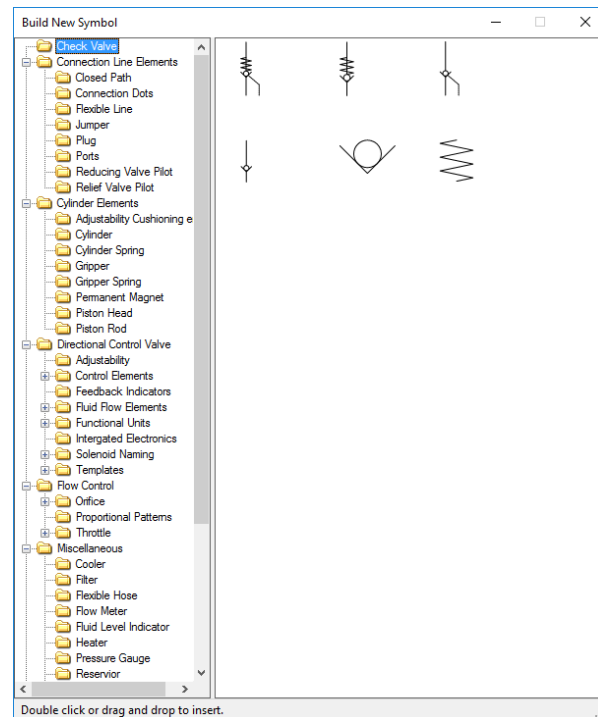

Build New Symbol –Basic Building Elements

4. Double click or drag and drop the basic elements to the drawing space.
5. Position the elements at the right place.
6. Insert the port names from the Port Names folder.

The Port Name symbol consists of a Connection Point and Port Name.

Once your design is complete, select the **Add New Symbol** to bring the newly built symbol into the library.

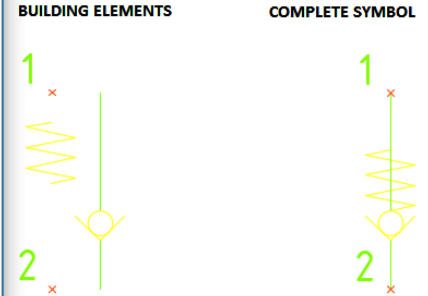
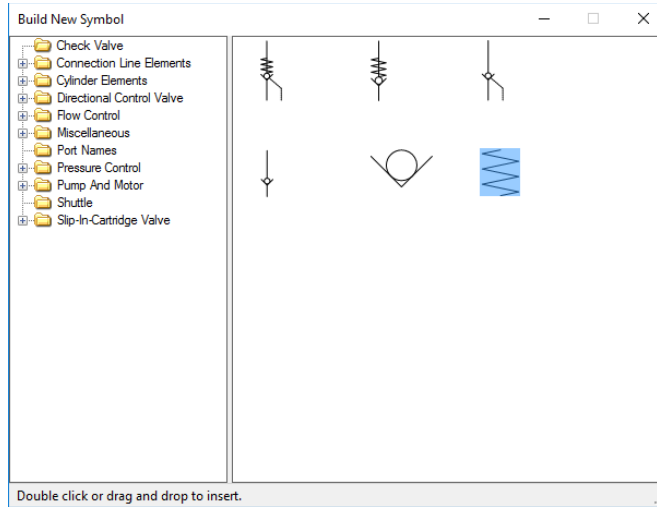

Basic Building Blocks inserted into the drawing space

1. Add New Symbol

Add newly designed or modified symbol in to the HyDraw® Symbol Library.

In the HyDraw Library Explorer, browse to the required folder, where you want to add a new symbol.

1. Click Manage Symbol.
2. Select **Add New Symbol** from the drop down.

The Add Symbol dialog box displays.

3. Select Application.
4. Select Component Type.
5. Click **OK**.
6. Select the symbol to add.
7. Specify the Insertion point.
8. Press **Enter/Tab**.

The symbol is added into the library.

Note:

You need to revisit the folder to view the inserted symbol.

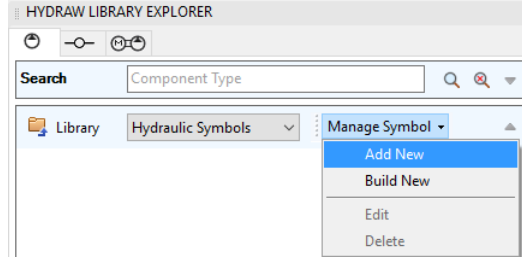

Manage Symbol - Add New Symbol

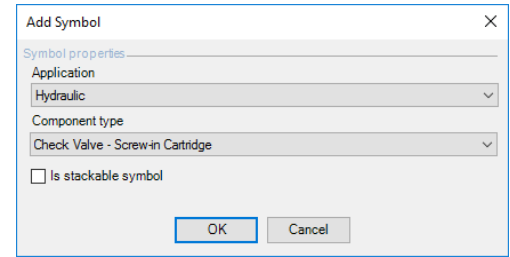

Add Symbol

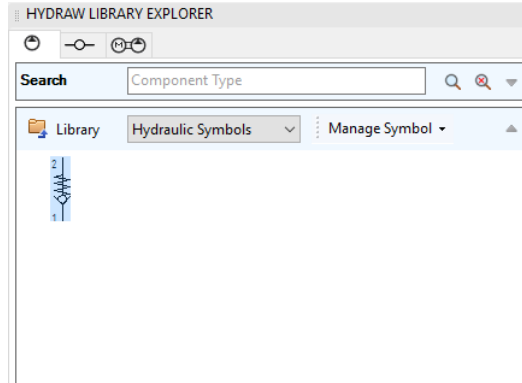

The New Symbol is added to HyDraw Library



2. Edit Master Symbol

Modify the master symbol available in the HyDraw® Symbol Library.

In the HyDraw Library Explorer, browse to the required folder and select the symbol to edit.

1. Click **Manage Symbol**.
2. Select **Edit Symbol** from the drop down.

The symbol displays on the drawing space along with the Edit Master Symbol dialog box.

3. Edit the symbol.

Edit Port

1. Type the new name in the Name column and the optional name in the Other Name column.
2. To delete the port, click .
3. Select **Name/Other Name** in the Display option.
4. Click **OK**.

The Name/Other name of the port displays with the symbol,

If both the names are selected, then dual port names are displayed.

Insert Port

1. Type the new name in the Name column and the optional name in the Other Name column.
2. Click **Insert** and insert the port on the symbol.
3. Specify the port insertion point.

The Edit Master Symbol dialog box reappears after the port insertion.

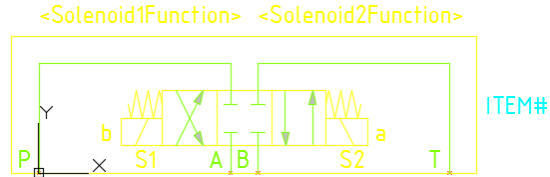



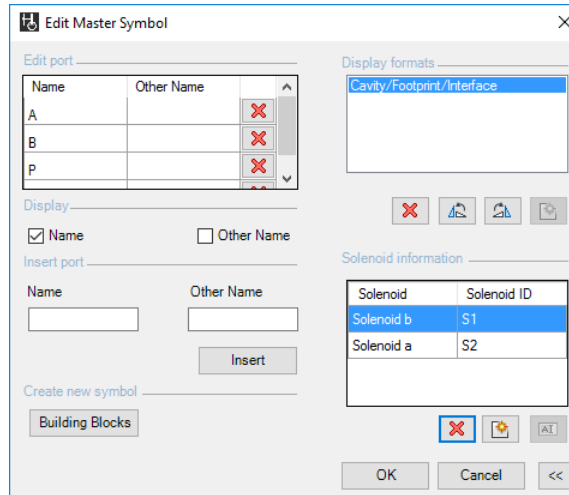

Edit Master Symbol





Edit Master Symbol

Display Formats

1. Click  to add the new display format.
2. Click  to rotate right.
3. Click  to rotate left.
4. To delete the earlier display format, click .

Solenoid Information

1. Click  to add the new solenoid.
2. Enter the Solenoid ID and Solenoid Name.
3. Click  to Update the Solenoid ID and Solenoid Name.
4. Click  to delete the solenoid from the list.
5. Click **OK**.

The modified symbol is updated in the library.

Note

- You need to revisit the folder to view the changes of the modified symbol.
- Click the Building Blocks to insert the basic building elements from the Building Blocks window.

3. Delete Symbol

Delete the master symbol available in the HyDraw® Symbol Library.

In the HyDraw Library Explorer, browse to the required folder and select the symbol to delete.

1. Click Manage Symbol.
2. Select **Delete** from the dropdown.
The Delete Symbol dialog box displays.
3. Click **Yes**.
Symbol is deleted from the library.

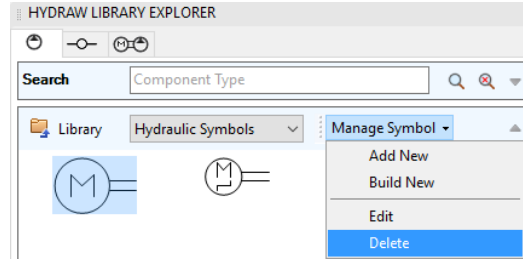

Manage Symbol – Delete Symbol

Caution:

The symbol once deleted, is permanently removed from the library and cannot be brought back.

83. Build New External Ports

Create custom external ports from the building elements supplied along with the library.

1. Add New External Ports

Add newly designed or modified external ports into the HyDraw® Symbol Library.

1. In the External Port Library of HyDraw Library Explorer, browse to the required folder, where you want to add a new symbol.
2. Click Manage Symbol.
3. Select **Add New** from the drop down.
4. Select the symbol to be inserted.
5. Specify the Insertion point.
6. Press **Enter/Tab**.

The symbol is inserted into the library.

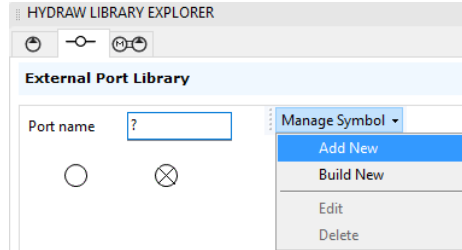

Manage Symbol > Add New External Port

Note:

The symbols should have minimum of one connection point.

2. Edit External Port Symbol

1. In the External Port Library select the symbol to edit.
2. Click Manage Symbol.
3. Select **Edit** from the drop down or Right click and select Edit.
The symbol displays on the drawing space along with the Edit Port Master Symbol dialog box.
4. Edit the symbol.

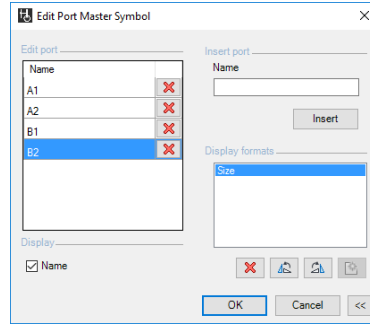

Edit Port Master Symbol

Edit Port

1. Type the new name in the **Name** column.
2. To delete the port, click .
3. Select **Name** in the Display option.
4. Click **OK**.
The Name of the port displays with the symbol.



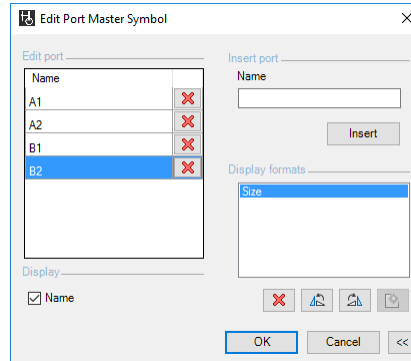

Insert Port

1. Type the new name in the **Name** column.
2. Click Insert and insert the port on the symbol.
3. Specify the port insertion point.
The Edit Port Master Symbol dialog box reappears after the port insertion.



Edit Port Master Symbol dialog box

Display Formats

1. Click  to add the new display format.
2. Click  to rotate right.
3. Click  to rotate left.
4. To delete the earlier display format, click .

3. Delete Symbol

Delete the master symbol available in the HyDraw® Symbol Library.

1. Click Manage Symbol.
2. Select **Delete** from the dropdown.

The Delete Symbol dialog box displays.

3. Click **Yes**.

The Symbol is deleted from the library.

Caution:

The symbol once deleted, is permanently removed from the library and cannot be brought back.

84. Build New Sub-Systems

Create sub-systems from the building elements supplied along with the library.

In the Sub-System library of HyDraw® Library Explorer, browse to the required folder, where you want to add a new symbol.

1. Click Manage Symbol.
2. Select **Build New** symbol from the drop down.

The Build New Symbol window displays.

The basic building block elements are structured in logical folders for easy access.

3. Browse to the required folder.

The Basic Building Elements are displayed in the right side window.

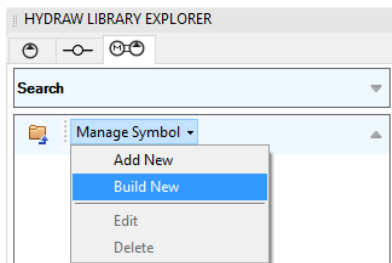

Manage Symbol - Build New

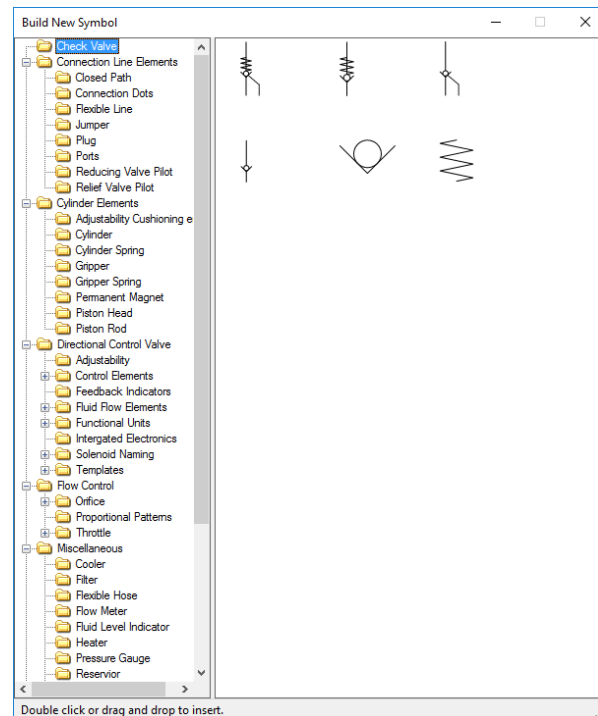

Build New Symbol –Basic Building Elements

4. Double click or drag and drop the basic elements to the drawing space.
5. Position the elements at the right place.
6. Insert the port names from the Port Names folder.
The Port Name symbol consists of a Connection Point and Port Name.
7. Once your design is complete, select the **Add New Sub-System** to bring the newly built symbol into the library.

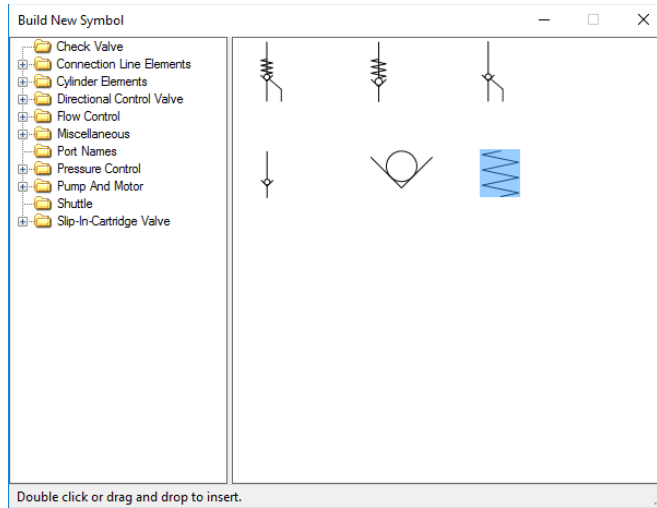

BUILDING ELEMENTS

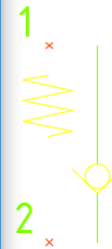

COMPLETE SYMBOL

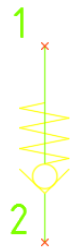

Basic Building Blocks inserted into the drawing space

1. Add New Sub-System

Add newly designed or modified sub-system in to the HyDraw® Sub-System Library.

In the Sub-System Library of HyDraw Library Explorer, browse to the required folder, where you want to add a new sub-system.

1. Click Manage Symbol.
2. Select **Add New Sub-System** from the drop down.

The Add Sub-System dialog box displays.

4. Select Application.
5. Select Sub-System Type.
6. Click **OK**.
7. Select the sub-system to add.
8. Specify the Insertion point.
9. Press **Enter/Tab**.

The sub-system is added into the library.

Note:

You need to revisit the folder to view the added sub-system.

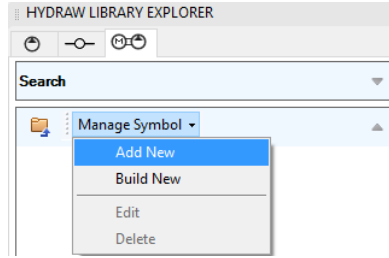

Manage Symbol - Add New Sub-System

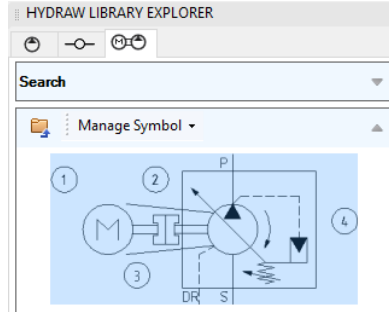

The New Sub-System is added to HyDraw Library

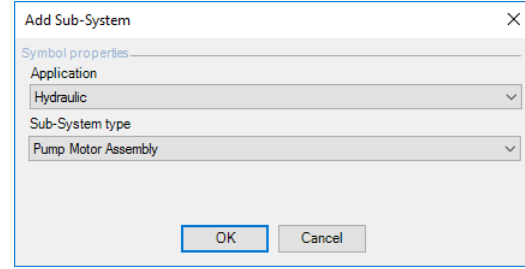

Add Sub-System

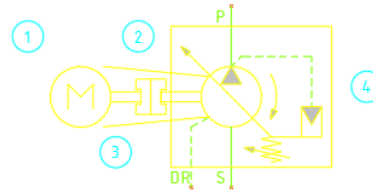

2. Edit Master Sub-System

Modify the master sub-system available in the HyDraw® Sub-System Library.

In the Sub-System Library of HyDraw Library Explorer, browse to the required folder and select the sub-system to edit.

1. Click Manage Symbol.
2. Select **Edit Sub-System** from the drop down.

The symbol displays on the drawing space along with the Edit Master Symbol dialog box.

3. Edit the sub-system.

Edit Port

1. Type the new name in the Name column and the optional name in the Other Name column.
2. To delete the port, click .
3. Select **Name/Other Name** in the Display option.
4. Click **OK**.

The Name/Other name of the port displays with the symbol,

If both the names are selected, then dual port names are displayed.

Insert Port

1. Type the new name in the Name column and the optional name in the Other Name column.
2. Click **Insert** and insert the port on the symbol.
3. Specify the port insertion point.

The Edit Master Sub-System dialog box reappears after the port insertion.

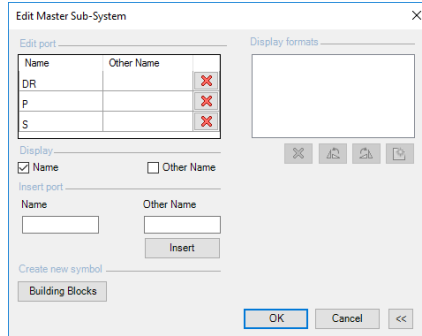



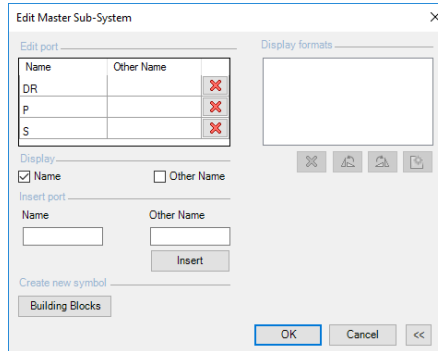
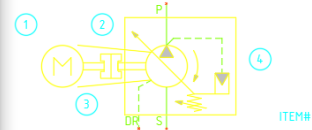

Edit Master Sub-System



Edit Master Sub-System

Display Formats

1. Click  to add the new display format.
2. Click  to rotate right.
3. Click  to rotate left.
4. To delete the earlier display format, click .

Note:

- You need to revisit the folder to view the changes of the modified sub-system.
- Click the Building Blocks to insert the basic building elements from the Building Blocks window.

3. Delete Sub-System

Delete Sub-System command enables you to delete the master sub-system available in the HyDraw® Sub-System Library.

In the Sub-System Library of HyDraw Library Explorer, browse to the required folder and select the symbol to delete.

1. **Click** Manage Symbol.
2. **Select Delete** from the dropdown.

The Delete Symbol dialog box displays.

3. Click **Yes**.

Sub-System is deleted from the library.

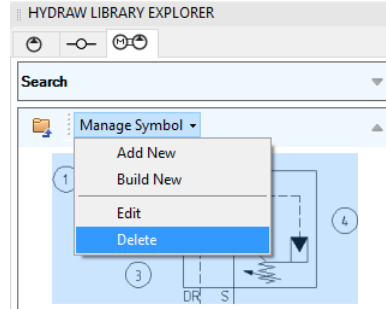

Manage Symbol – Delete Sub-System

Caution:

The sub-system once deleted, is permanently removed from the library and cannot be brought back.

85. Manage HyDraw CAD Drawings thro' Vault

Manage HyDraw CAD Drawing revisions through Vault.

Like all other dwg files, HyDraw CAD files can be added to Vault, viewed in Vault and opened from Vault.

The Files can be also checked In and checked Out, and maintain revisions from the Vault Interface.

Note:

For more details regarding Vault usage, refer Autodesk Vault online knowledge base.

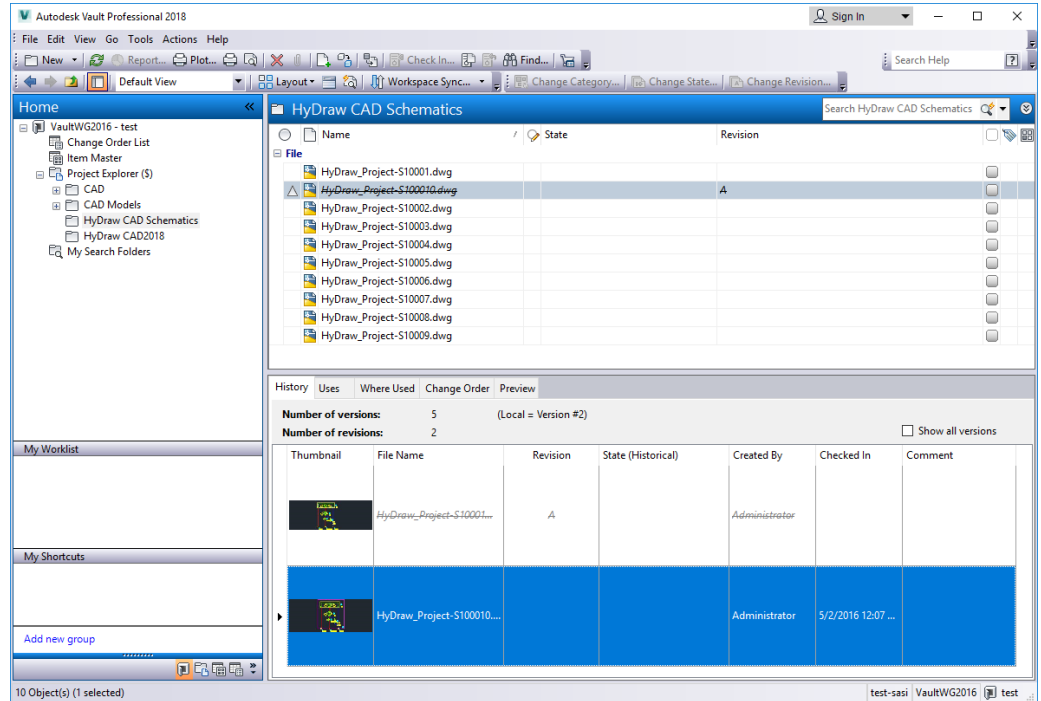

Autodesk Vault Professional 2019

A

About HyDraw, 181
 Accessories, 97, 102
 Actuation Chart, 27
 Add Accessories, 95
 Add New Accessories, 98
 Add New Display Format, 137
 Add New External Ports, 200
 Add New Sub-System, 205
 Add New Symbol, 196
 Align External Port Names, 119
 Align Symbol Ports, 118
 Align Symbols, 115
 Annotations, 130
 Application, 17
 Authorize Standalone License, 186
 Auto Naming and Grouping of Components, 60

B

Balloon, 46
 Borrowing Network License, 187
 Build New External Ports, 200
 Build New Symbols, 194, 203

C

CAD Files, 101
 Calculator, 154
 Change Text Height, 131
 Check, 165
 Collate CAD Files, 153

Collate Documents, 152
 Collate Files, 151
 Command options, 36
 Component Data Available, 174
 Components, 102
 Configure External Port, 64
 Connect Ports and Symbols, 83
 Connection Tab, 39
 Contact Info, 176
 Convert, 161
 Convert to HyDraw, 162
 Convert to HyDraw Connection, 163
 Convert to HyDraw Symbol, 163
 Copy Properties, 104
 Create and Insert Hose List, 145
 Create and Insert Net List, 148
 Create and Insert Parts List, 139
 Create and Insert Ports List, 143
 Create Design Note List, 150
 Create Solenoid Actuation Chart, 147
 Customize Hose List Format, 146
 Customize HyDraw Layer Properties, 34
 Customize Parts List Format, 142
 Customize Port List Format, 144

D

Data Access Settings, 172
 Delete a Symbol, 123
 Delete Accessories, 99
 Delete Sub-System, 208
 Delete Symbol, 199
 Design Note, 29
 Design Requirements, 92

Display Formats, 198
 Dock HyDraw Property Manager, 13
 Documents, 100
 Drawing Template, 45

E

Edit Design Notes, 127
 Edit External Port Symbol, 201
 Edit in Place, 121
 Edit Jumping Reference, 128
 Edit Master Sub-System, 206
 Edit Master Symbol, 197
 Edit Port, 197
 Edit Properties, 103
 Edit Solenoid Information, 110
 Edit Symbol Port, 120
 Edit Title Block, 170
 Envelope Line, 32
 Envelopes, 102
 Explode Sub-System, 67
 Export Settings, 189
 Export to MDTTools, 157
 External Port, 20
 External Ports, 102

F

Fetch Pipe, Tube and Hose Data, 84
 Filter Search Results, 57
 Find Jumping Reference, 129
 Flip Symbols, 117
 FluidPowerTools.com, 171

G

Gauge Port, 43

H

Help, 4, 178, 179
Help for FluidPowerTools.com, 173
Hose List, 23
HyDraw CAD Ribbon Menu, 7
HyDraw Library Explorer, 9
HyDraw Options, 17
HyDraw Property Manager, 12
HyDraw Shortcuts, 8
HyDraw Startup, 6

I

Import Settings, 190
Insert a Symbol by Library, 51
Insert Connection, 82
Insert Envelope, 77
Insert External Port, 62
Insert from Parts List, 74
Insert Gauge Port, 78
Insert Hose List, 145
Insert Jumping Reference, 80
Insert Orifice Disc, 79
Insert Port, 197
Insert Ports List, 143
Insert Sub-Systems, 66
Insert Symbol, 48
Insert Symbol from Component Search, 60
Insert Symbol from Library, 60
Insert Symbol from Parts List, 61
Insert Symbol Port, 76

Insert Symbols, 47
Insert Terminators, 75
Insert Title Block, 169
Installation, 183
Installation & Setup, 182
Internet Setting, 177
Internet Settings, 37
Introduction, 2
Item ID, 41

L

Library Network Configuration, 191
Library Path, 30
License Information, 180
Lists, 138
Lists & Charts, 21
Load HyDraw Property Manager on Startup, 16
Load on startup, 32

M

Make Connections, 81
Manage HyDraw CAD Drawings thro' Vault, 209
Match Connections, 87
MDTools Interface, 156
Merge Connection, 88
Migrate Settings, 188
Misc., 31
Model Data, 93
Models Context Menu, 58
Modify Connection, 45
Modify Symbols, 113
Move Symbol, 114

N

Net List, 28

O

Open HyDraw Property Manager, 13

P

Ports List, 25
Property Display, 44
Proxy Connection, 193
Pump Motor Adaptor Data, 96
Purge Price Data, 109
Purge Property, 107

R

Reassign Hose ID, 135
Refresh Properties, 105
Replace Accessories, 95
Replace External Port, 62
Replace Symbol, 50, 52
Reset Connections, 89
Resign Item ID, 134
Rotate Property Text, 132
Rotate Symbols, 116

S

Save Accessories, 98
Schematic Check, 166
Search and Insert Sub-Systems, 68
Search and Insert Symbol by Component type, 49
Search and Insert Symbol by Components, 53

- Select from Library, 94
- Select Port data from Library, 63
- Selected Item, 14
- Selected Item Properties, 91
- Set Online Services (FPT), 192
- Show/Hide Design Notes, 126
- Show/Hide Port Names, 125
- Show/Hide Properties, 133
- Software Installation, 184
- Solenoid Information, 198
- Solenoid Naming, 35
- Specify Properties, 90
- Stack Symbols, 124
- Stretch Connections, 86
- Submit Authorization Request, 185
- Subscription Information, 173

- Sub-System, 122
- Sub-Systems, 102
- Support, 4
- Symbol, 91
- Symbol Color, 33
- System Properties, 102
- System Requirements, 183
- System tab, 15

T

- Terms of Usage, 175
- Text Size, 31
- Title Block, 168

U

- Unit Converter, 155
- Units, 18
- Units tab – Advanced Options, 19
- Update Balloons, 136
- Update Drawing, 164
- Update from Excel, 38, 111
- Update Property List, 106
- Usage Authorization, 185
- Use and Borrow Network License, 187
- Using Network License, 187

W

- Workspace, 5



VEST, Inc.

3250 W, Big Beaver Road, # 440, Troy, MI 48084 USA

+1 248 649 9550 sales@VESTusa.com <https://VESTusa.com>

© 2018, VEST, Inc. All rights reserved.